

Advanced Monolithic Systems

AMS2115

FAST TRANSIENT RESPONSE LOW DROPOUT REGULATOR

FEATURES

- Fast Transient Response
- Dropout Voltage Defined by FET Used
- Very Tight Load Regulation
- High Side Sense Current Limit

APPLICATIONS

- Microprocessor Supplies
- Video Card Supplies
- Low Voltage Logic Supplies
- GTL Termination

GENERAL DESCRIPTION

The AMS2115 is a single IC controller that drives an external N channel MOSFET as a source follower to produce a fast transient response, low dropout voltage regulator. The fast transient load performance is obtained by eliminating expensive tantalum or bulk electrolytic output capacitors in the most demanding modern microprocessor applications. Precision-trimmed adjustable and fixed output voltage versions accommodate any required microprocessor power supply voltage. By selecting the N-channel MOSFET RDS(ON) a very low dropout voltage can be achieved. A protection feature includes a high side current limit amplifier that activates a circuit to limit the FET gate drive. A shutdown pin turns off the gate drive and some internal circuits to reduce quiescent current. AMS2115 is offered in 8L SOIC and 8L PDIP package.

ORDERING INFORMATION:

| PACKAGE TYPE | | OPERATING JUNCTION TEMPERATURE RANGE |
|--------------|--------------|--------------------------------------|
| 8L PDIP | 8L SOIC | |
| AMS2115P | AMS2115S | -0 to 125° C |
| AMS2115P-1.5 | AMS2115S-1.5 | -0 to 125° C |
| AMS2115P-1.8 | AMS2115S-1.8 | -0 to 125° C |
| AMS2115P-2.5 | AMS2115S-2.5 | -0 to 125° C |
| AMS2115P-3.3 | AMS2115S-3.3 | -0 to 125° C |
| AMS2115P-5.0 | AMS2115S-5.0 | -0 to 125° C |

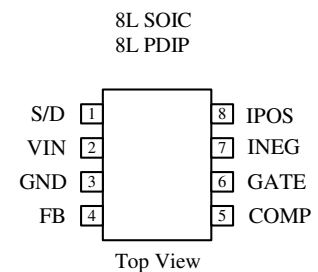

TYPICAL APPLICATION:

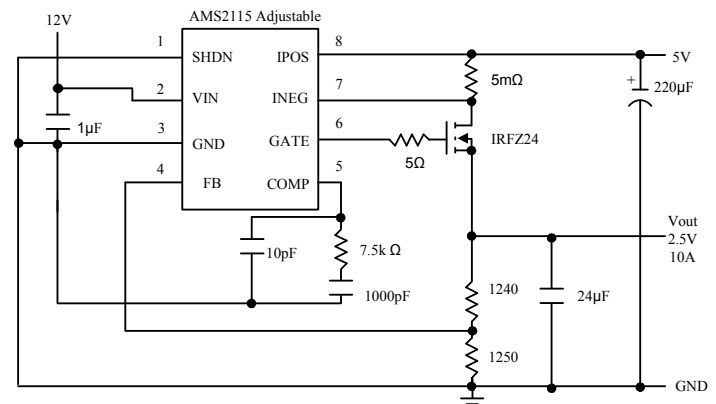
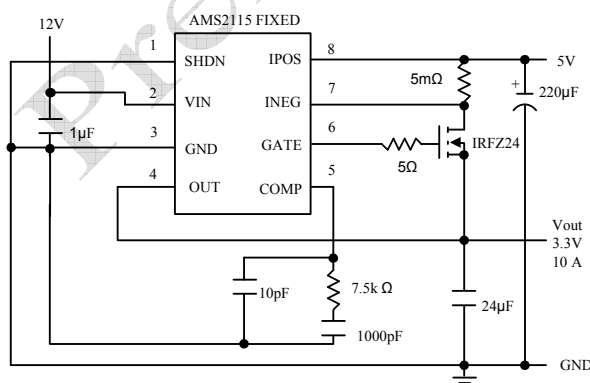

ABSOLUTE MAXIMUM RATINGS (Note 1)

| | |
|--------------------------------|------------------|
| Input Voltage | 20V |
| Operating Junction Temperature | 0°C to 125°C |
| ESD | 2000V |
| Storage temperature | - 65°C to +150°C |

| | |
|---------------------------|-------------------------------------|
| Soldering information | |
| Lead Temperature (10 sec) | 300°C |
| Thermal Resistance | |
| SO-8 package | $\phi_{JA} = 130^{\circ}\text{C/W}$ |
| 8L-PDIP package | $\phi_{JA} = 100^{\circ}\text{C/W}$ |

ELECTRICAL CHARACTERISTICS

$T_A = 25^{\circ}\text{C}$, $V_{IN} = 12\text{V}$, $I_{POS} = I_{NEG} = 5\text{V}$, $\text{SHDN} = 0\text{V}$ unless otherwise noted.

| Parameter | Device | Conditions | Min | Typ | Max | Units |
|---|-------------|-------------------------------|-----------------------|---------------------|-----------|----------|
| Supply Current (I _{sy}) | | | | 4.5 | 7 | mA |
| Reference Voltage (V _{REF}) | AMS2115 | | 1.238 | 1.250 | 1.26 | V |
| Output Voltage (V _{OUT}) | AMS2115-1.5 | | 1.485 | 1.500 1.0 | 1.51 5 | V V |
| Output Voltage (V _{OUT}) | AMS2115-1.8 | | 1.782 | 1.800 | 1.81 | V |
| Output Voltage (V _{OUT}) | AMS2115-2.5 | | 2.475 | 2.500 | 2.52 | V |
| Output Voltage (V _{OUT}) | AMS2115-3.3 | | 3.267 | 3.300 | 3.33 | V |
| Output Voltage (V _{OUT}) | AMS2115-5.0 | | 4.950 | 5.000 | 5.05 | V |
| Line Regulation | AMS2115-XX | 10 V ≤ V _{IN} ≤ 20V | | 0.01 | 0.3 | %/V |
| Input Bias Current (I _{fb}) | AMS2115 | FB = V _{FB} | | -3.0 | -4.0 | μA |
| OUT Divider Current | AMS2115-XX | OUT = V _{OUT} | | 0.5 | 1.0 | mA |
| Gate Output Swing Low | AMS2115-XX | I _{Gate} = 0mA | | 0.1 | 0.5 | V |
| Gate Output Swing High | AMS2115-XX | I _{Gate} = 0mA | V _{IN} - 1.6 | V _{IN} - 1 | | V |
| IPOS + INEG Supply Current | AMS2115-XX | 3V ≤ IPOS ≤ 20V | 0.3 | 0.625 | 1.0 | mA |
| Current Limit Threshold Voltage | AMS2115-XX | | 42 37 | 50 50 | 58 63 | mV mV |
| Current Limit Threshold Voltage Line Regulation | AMS2115-XX | 3V ≤ IPOS ≤ 20V | | -0.20 | -0.50 | %/V |
| Shut Down Current (Input Shut Down – High) | AMS2115-XX | V _{Shutdown} = 2.0 V | | 5.0 | 8.0 | μA |
| Shut Down Input logic (Shut Down - Low) | AMS2115-XX | Low (Regulator On) | | 1.2 | 1.4 | V |
| Shut Down Input logic (Shut Down – High) | AMS2115-XX | High (Regulator Off) | 2.0 | 1.5 | | V |
| Shut Down Hysteresis | AMS2115-XX | From High To Low | | 150 | | mV |
| Output Voltage TC (V _{OUT} TC) | AMS2115-XX | ΔT = TA to 125°C | | 30 | | ppm/°C |
| Reference Voltage TC (V _{REF} TC) | AMS2115 | ΔT = TA to 125°C | | 30 | | ppm/°C |

Parameters identified with **boldface type** apply over the full operating temperature range.

Note 1: Absolute Maximum Ratings indicate limits beyond which damage to the device may occur. For guaranteed specifications and test conditions, see the Electrical Characteristics. The guaranteed specifications apply only for the test conditions listed.

Note 2: Line regulation is guaranteed up to the maximum input voltage.

Note 3: XX represents all output voltages.

PIN FUNCTIONS

S/D (Pin 1)

This is a shutdown pin that provides GATE drive latching capability. The pin is also the input to a comparator referenced to V_{REF} (1.25V). When the pin pulls above V_{REF} , the comparator latches the gate drive to the external MOSFET off. The comparator typically has 150mV of hysteresis and the Shutdown pin can be pulled low to reset the latching function. This pin provides overvoltage protection or thermal shutdown protection when driven from various resistor divider schemes. S/D pin is clamped at 2.5V.

V_{IN} (Pin 2)

This is the input supply for the IC that powers the majority of internal circuitry and provides sufficient gate drive compliance for the external N-channel MOSFET. The typical supply voltage is 12 with 4.5 mA of quiescent current. The maximum operating V_{IN} is 20V and the MOSFET at max. $I_{OUT} + 1.6V$ (worst-case V_{IN} to GATE output swing).

GND (Pin 3)

Analog Ground. This pin is also the negative sense terminal for the internal 1.25V reference. Connect external feedback divider networks that terminate to GND and frequency compensation components that terminate to GND directly to this pin for best regulation and performance.

FB (Pin 4) Adjustable Version

This is the inverting input of the error amplifier for the adjustable voltage AMS 2115. The noninverting input is tied to the internal 1.25V reference. Input bias current for this pin is typically $-3 \mu A$ flowing out of the pin. This pin is normally tied to a resistor divider network to set output voltage. Tie the top of the external resistor divider directly to the output voltage for best regulation performance.

OUT (Pin 4) Fixed Output Voltage

This is the input of the error amplifier for the fixed voltage AMS 2115-X. The fixed voltage parts contain a precision resistor divider network to set output voltage. The typical resistor divider current is 1 mA into the pin. Tie this pin directly to the output voltage for best regulation performance.

COMP (Pin 5)

This is the high impedance gain node of the error amplifier and is used for external frequency compensation. Frequency compensation is generally performed with a series RC network to ground.

GATE (Pin 6)

This is the output of the error amplifier that drives N-channel MOSFETs with up to 5000pF of “effective” gate capacitance. The typical open-loop output impedance is 2Ω . When using low input capacitance MOSFETs (1500pF), a small gate resistor of 2Ω to 10Ω dampens high frequency ringing created by an LC resonance that is created by the MOSFET gate’s lead inductance and input capacitance. The GATE pin delivers up to 50mA for a few hundred nanoseconds when slewing the gate of the N-channel MOSFET in response to output load current transients.

INEG (Pin 7)

This is the negative sense terminal of the current limit amplifier. A small sense resistor is connected in series with the drain of the external MOSFET and is connected between the IPOS and INEG pins. A 50mV threshold voltage in conjunction with the sense resistor value sets the current limit level. The current sense resistor can be low value shut or can be made from a piece of PC board trace. If the current limit amplifier is not used tie the INEG and IPOS to power input voltage. This action disables the current limit amplifier.

IPOS (Pin 8)

This is the positive sense terminal of the current limit amplifier. Tie this pin directly to the main power input voltage from which the output voltage is regulated. This pin is also the input to a comparator that monitors the power input voltage and keeps the GATE voltage low until power input voltage is at least 1V. This prevents the external N Channel MOSFET to turn on before V power is on thus eliminating possible voltage spikes in the output voltage when powered up.

PACKAGE DIMENSIONS inches (millimeters) unless otherwise noted.

8 LEAD SOIC PLASTIC PACKAGE (S)

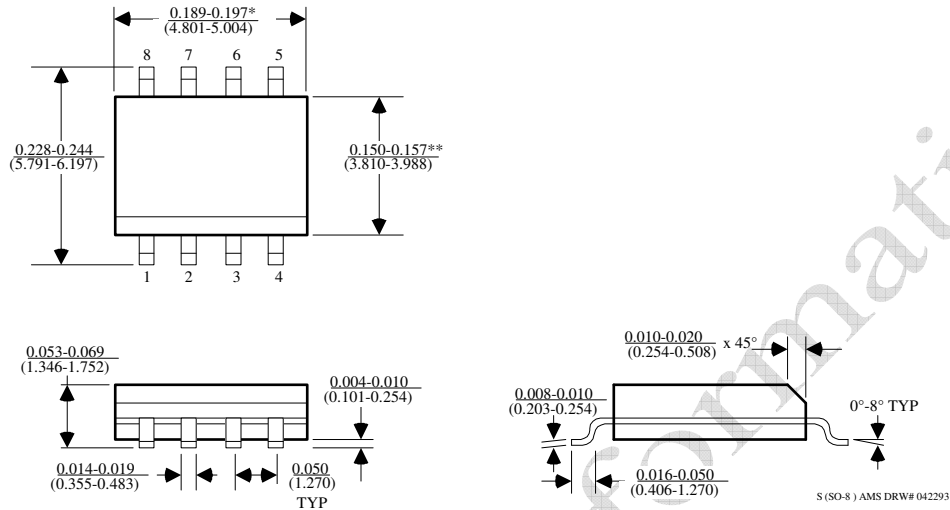

*DIMENSION DOES NOT INCLUDE MOLD FLASH. MOLD FLASH SHALL NOT EXCEED 0.006" (0.152mm) PER SIDE

**DIMENSION DOES NOT INCLUDE INTERLEAD FLASH. INTERLEAD FLASH SHALL NOT EXCEED 0.010" (0.254mm) PER SIDE

8 LEAD PLASTIC DIP PACKAGE (P)

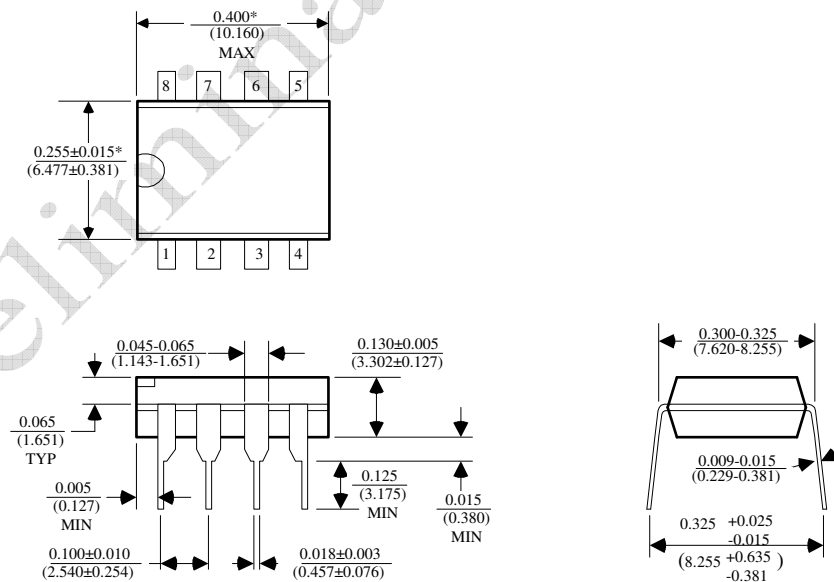

*DIMENSIONS DO NOT INCLUDE MOLD FLASH OR PROTUSIONS. MOLD FLASH OR PROTUSIONS SHALL NOT EXCEED 0.010" (0.254mm)