

3A Fast Transient Linear Regulator

General Description

The AMS3132 is a high performance linear regulator with very low dropout voltage and excellent transient response. It is designed to operate with wide input voltage range of 1.5 – 7Volts making it ideal for two step conversion while maintaining high efficiency for many power sensitive applications. The device is capable of supplying 3A of output current with a typical dropout voltage of 700mV at 3A. The product is available in either fixed or adjustable output voltage.

The linear regulator has been optimized for noise sensitive applications. The device includes an optional enable pin for electrical on/off of the regulator. Forcing the enable pin to logic low shuts down the LDO and reduces the supply current to less than 1 μ A.

The product includes complete short-circuit and thermal protection. The combination of these two internal protection circuits gives the device a comprehensive safety system to safe guard against extreme adverse operating conditions.

The AMS3132 is available in a 5-pin surface mount TO263 package, and it is rated for -40°C to +125°C temperature range.

Features

- V_{IN} range: 1.5 – 7V
- Fixed and Adjustable output voltage as low as 0.6V
- 3A maximum output current
- 700mV typical dropout voltage at 3A
- Low self noise
- Optional Power Good (PG) output
- Optional Enable (EN) pin for LDO on/off
- 125 μ A typical supply current
- PSRR >40dB at 10KHz
- Stable with Electrolytic, Tantalum or Ceramic capacitors
- Current Limit protection
- Over-Temperature Shutdown
- -40 to +125°C temperature range
- Available in a 5-pin surface mount TO-263 package
- RoHS & WEEE compliant

Applications

- Set-top Box
- DVD, Blue-ray DVD writers
- LCD TVs and LCD monitors
- Battery Powered Equipment
- Infotainment
- Wireless & RF Applications
- High Efficiency “Green” Laptops & notebook

Typical Application

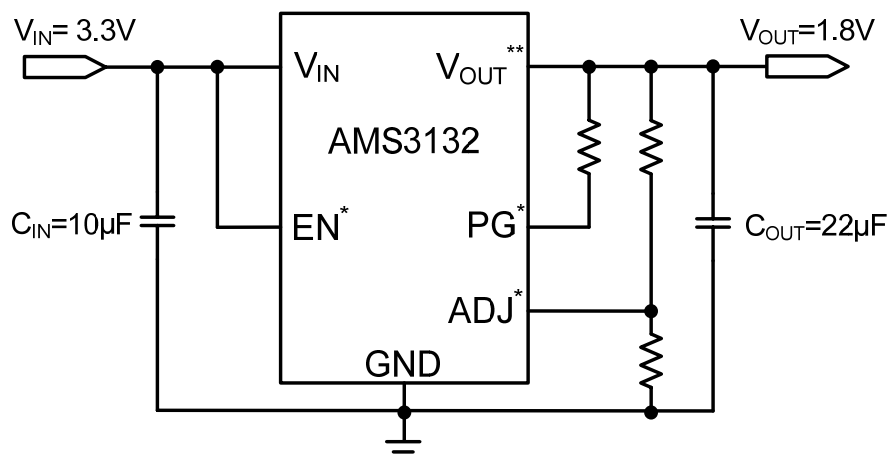

* Optional Function Pins are available

** Optional Fixed and Adjustable V_{OUT} are available

3A Fast Transient Linear Regulator

Pin Description (TO-263 5-Pin Package)

Pin #	Symbol	Description
1	EN	Enable pin. It controls the electrical on/off of the device. When connected to logic low, the device shuts off and consumes less than 1 μ A of current. Logic high will resume normal operation.
	PG	Power Good pin. It is an open collector, active high output that indicates the status of the output voltage. When output voltage (V_{OUT}) exceeds the PG trip threshold, the PG pin goes in to a high impedance state. When the device is out of regulation or shutdown, the PG pin is pulled low. A 10K Ω to 1M Ω resistor should be connected from PG to V_{OUT} .
2	V_{IN}	Input supply Voltage. It powers the internal control circuitry and the internal power switch. Bypass V_{IN} with at ceramic capacitor from this pin to ground.
3	GND	Ground connection.
4	V_{OUT}	Output Voltage
5	ADJ	Provides feedback to error amplifier from the resistive divider that sets the output voltage.
	PG	Power Good pin. It is an open collector, active high output that indicates the status of the output voltage. When output voltage (V_{OUT}) exceeds the PG trip threshold, the PG pin goes in to a high impedance state. When the device is out of regulation or shutdown, the PG pin is pulled low. A 10K Ω to 1M Ω resistor should be connected from PG to V_{OUT} .

Pin Configuration

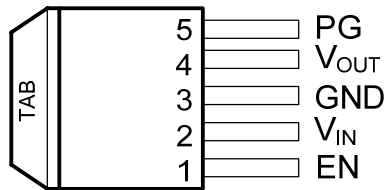

5-Pin TO-263 Fixed Voltage
with Power Good Option
AMS3132-XX-PG

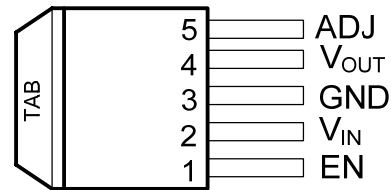

5-Pin TO-263 Adjustable
Voltage Option
AMS3132M

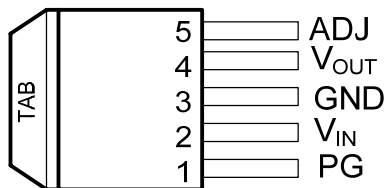

5-Pin TO-263 Adjustable Voltage
with Power Good Option
AMS3132M-PG

3A Fast Transient Linear Regulator

Absolute Maximum Ratings ⁽¹⁾

Maximum Input Supply Voltage (V_{IN}).....	-0.3V to 15V
Enable Voltage (EN).....	-0.3V to 15V
Power Good (PG).....	-0.3V to 15V
Adjustable Voltage (ADJ).....	-0.3V to 3V
Storage Temperature Range.....	-65°C to 150°C
Lead Temperature.....	260°C
Junction Temperature.....	125°C

Recommended Operating Conditions ⁽²⁾

Input Voltage.....	1.5V to 7V
Ambient Operating Temperature.....	-40°C to 125°C

Thermal Information

TO263-5 θ_{JA} ⁽³⁾	30°C/W
--	--------

Electrical Characteristics

Unless otherwise noted: $V_{IN}=3.3V$; $V_{OUT}=1.8V$; $C_{IN}=10\ \mu F$; $C_{OUT}=22\ \mu F$; $-40^{\circ}C \leq T_A=T_J \leq 85^{\circ}C$; $T_{J(Max.)}=125^{\circ}C$; Typical values are $T_A=25^{\circ}C$

Parameter	Symbol	Conditions	Min.	Typ.	Max.	Units
Output Voltage Accuracy	V_{OUT}		-3		3	%
Adjustable Voltage	V_{ADJ}	Adjustable V_{OUT} only	0.588	0.6	0.612	V
Adjustable pin bias current	I_{ADJ_Bias}	Adjustable V_{OUT} only		10	100	nA
Maximum Output Current	I_{OUT_Max}		3			A
Load Regulation		$I_{OUT}=0 - 3A$		0.1		%
Line Regulation		$V_{IN}=3.0 - 7.0V$; $I_{OUT}=100mA$		0.1		%
Supply Current	I_{SUP}	$V_{IN}=3.3V$, $I_o=0A$		0.6	1	mA
Shutdown Current	I_{SHDN}	$V_{IN}=3.3V$, $V_{EN}=0V$		<1	3	μA
Current Limit	I_{LIM}			6		A
Dropout Voltage	V_{DO}	$I_{OUT}=0.1A$; $V_{OUT}=95\%$ of $V_{OUT(NOM)}$		60		mV
		$I_{OUT}=1A$; $V_{OUT}=95\%$ of $V_{OUT(NOM)}$		220		
		$I_{OUT}=2A$; $V_{OUT}=95\%$ of $V_{OUT(NOM)}$		420		
		$I_{OUT}=3A$; $V_{OUT}=95\%$ of $V_{OUT(NOM)}$		700		
PSRR	$\Delta V_{OUT}/\Delta V_{IN}$	$F=10KHz$ $I_o=20mA$		40		dB
Output Noise Voltage	e_n	BW= 100Hz –100 KHz $C_{OUT} = 22\ \mu F$ $I_{OUT} = 2.75A$		125		$\mu V(rms)$
Enable Threshold Low	$V_{EN(L)}$	Optional EN Pin present		1.2		V
Enable Threshold High	$V_{EN(H)}$	Optional EN Pin present		1.3		V
Input Enable Low Current	$I_{EN(L)}$	$V_{EN} = 0V$		0	10	nA
Input Enable High Current	$I_{EN(H)}$	$V_{EN} = 1.5V$		150	300	nA
Power Good Low Threshold	V_{PG}	% of V_{OUT} PG ON / Opt. PG pin only	89			%
Power Good High Threshold	V_{PG}	% of V_{OUT} PG OFF / Opt. PG pin only			97	%
Power Good Output Low Voltage	V_{PGL}	IPG_SINK = 500 μA , Fault Condition		200	300	mV
Power Good Leakage Current	I_{PG}	PG off, $V_{PG} = 12V$		0.01		μA
Thermal Shutdown	T_{SD}			145		$^{\circ}C$
Thermal Shutdown Hysteresis	T_{SD_HYS}			15		$^{\circ}C$

Notes:

- Stresses above those listed in Absolute Maximum Ratings may cause permanent damage to the device.
- Junction to ambient thermal resistance with the TO-263 package tab soldered to a double side printed circuit board with 2.5 in² of (1 oz.) copper area.
- With package soldering to 0.5in² copper area over backside ground plane or internal power plane θ_{JA} can vary from 20°C/W to >40°C/W depending on mounting technique. The thermal resistance Junction to Case is 45°C/W. Total power dissipation for the switching regulator and the LDO should be taken in consideration when calculating the output current capability of each regulator.

Typical Performance Characteristics ($T_A = 25^\circ\text{C}$ unless otherwise specified)

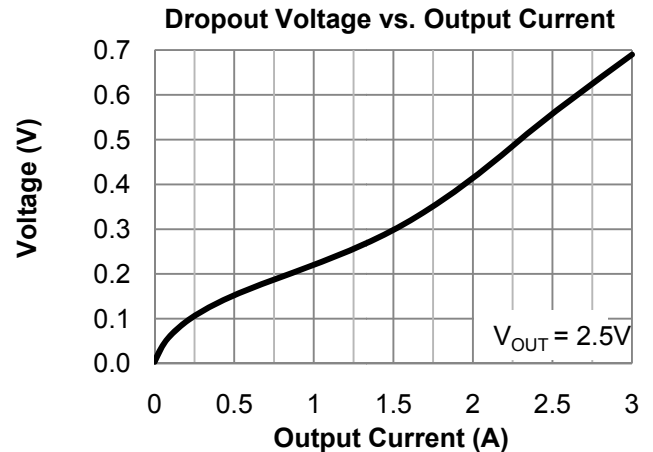
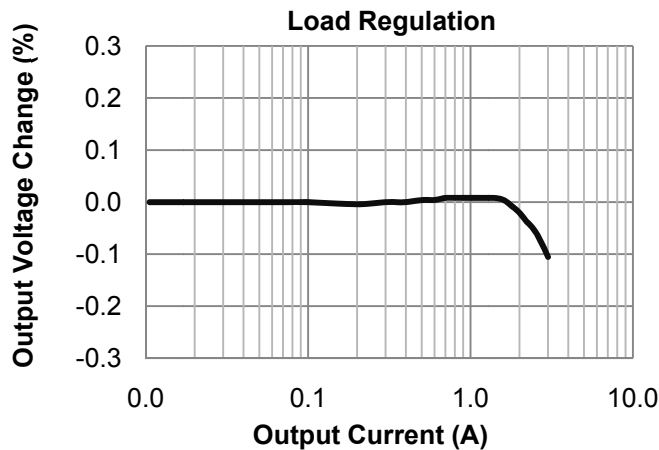
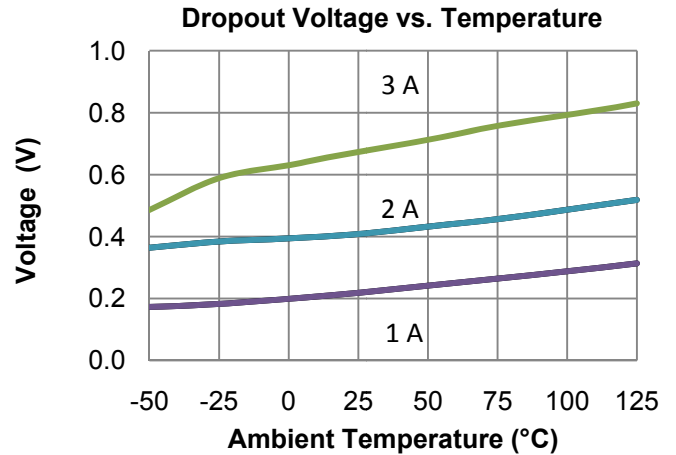
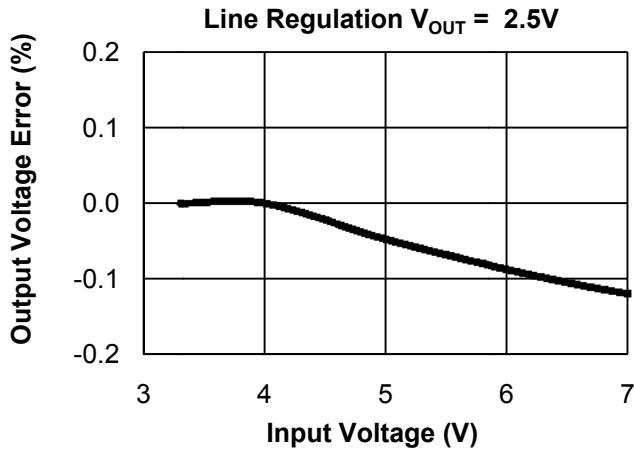
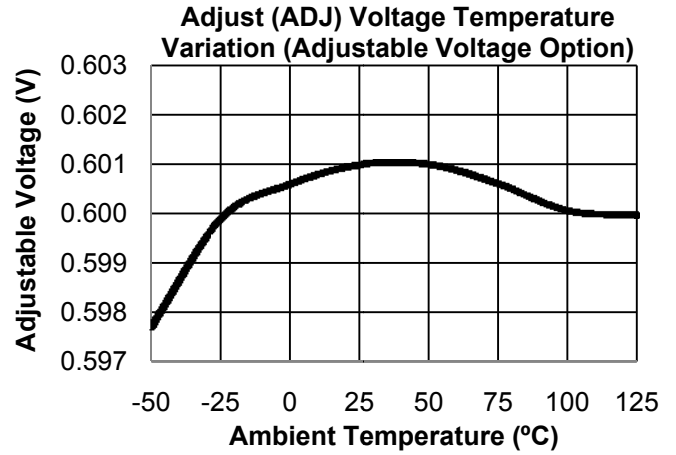
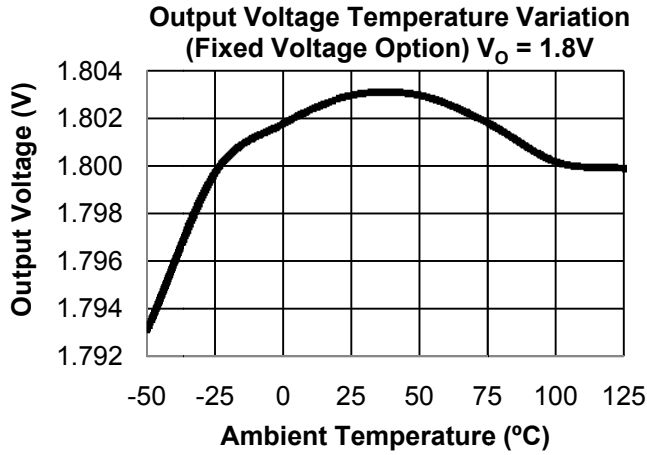

3A Fast Transient Linear Regulator

Typical Performance Characteristics ($T_A = 25^\circ\text{C}$ unless otherwise specified)

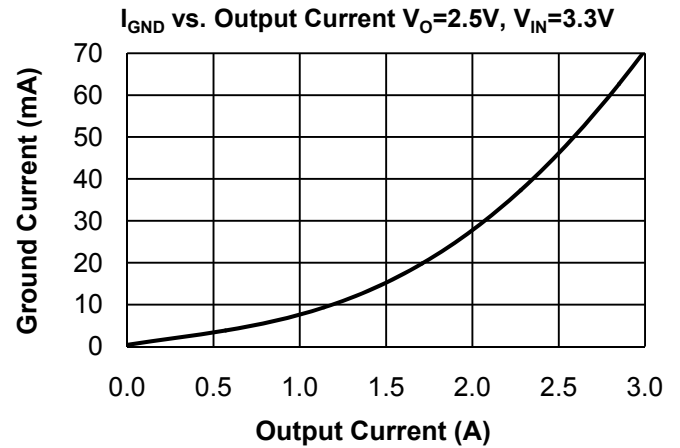
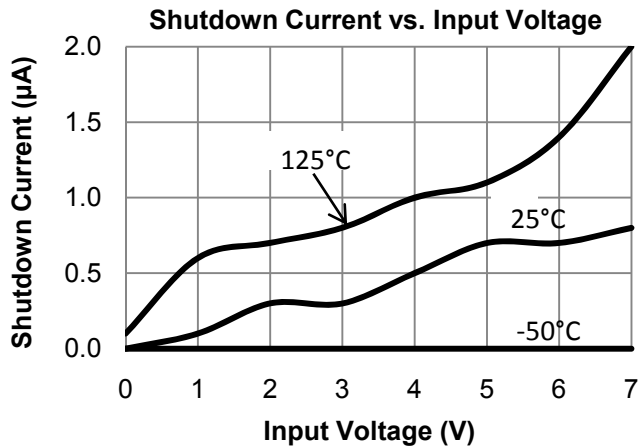

Load Transient
200mA to 2.8A, $V_{\text{OUT}}=2.5\text{V}$, $V_{\text{IN}}=3.6\text{V}$, $C_{\text{IN}}=C_{\text{OUT}}=22\mu\text{F}$

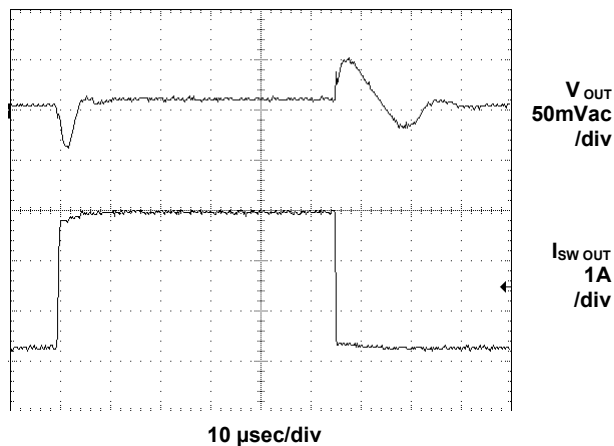

Enable Start-Up
2.5A, $V_{\text{OUT}}=2.5\text{V}$, $V_{\text{IN}}=3.3\text{V}$, $C_{\text{IN}}=C_{\text{OUT}}=22\mu\text{F}$

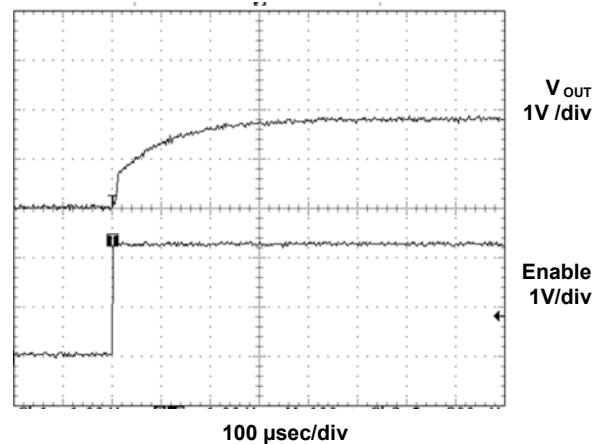

Functional Block Diagram

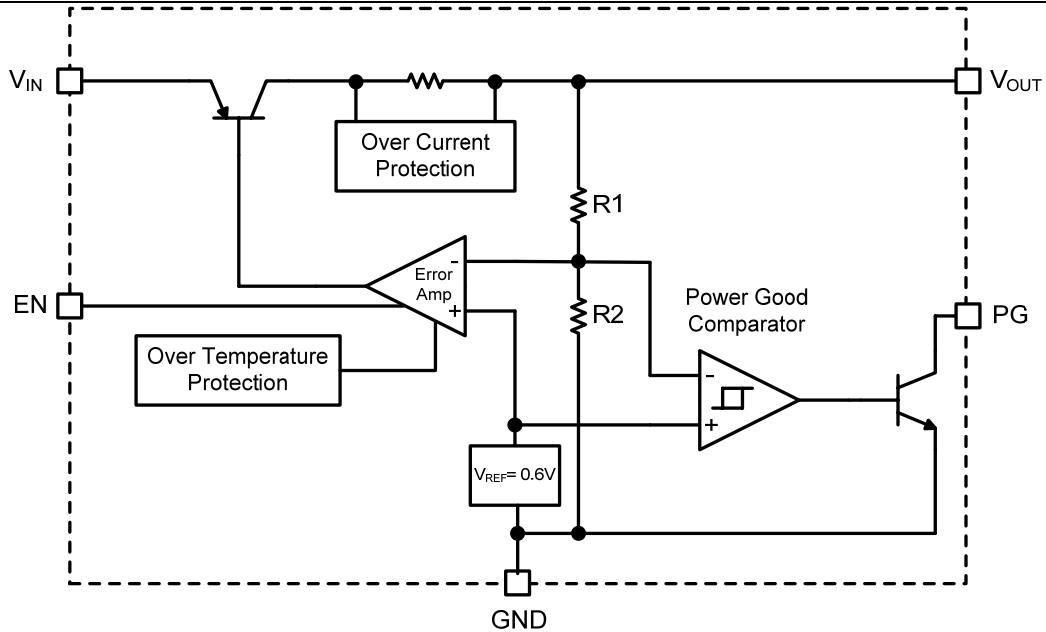

Figure 1: Block Diagram of AMS3132 5-Pin TO-263 Fixed Voltage with Power Good Option

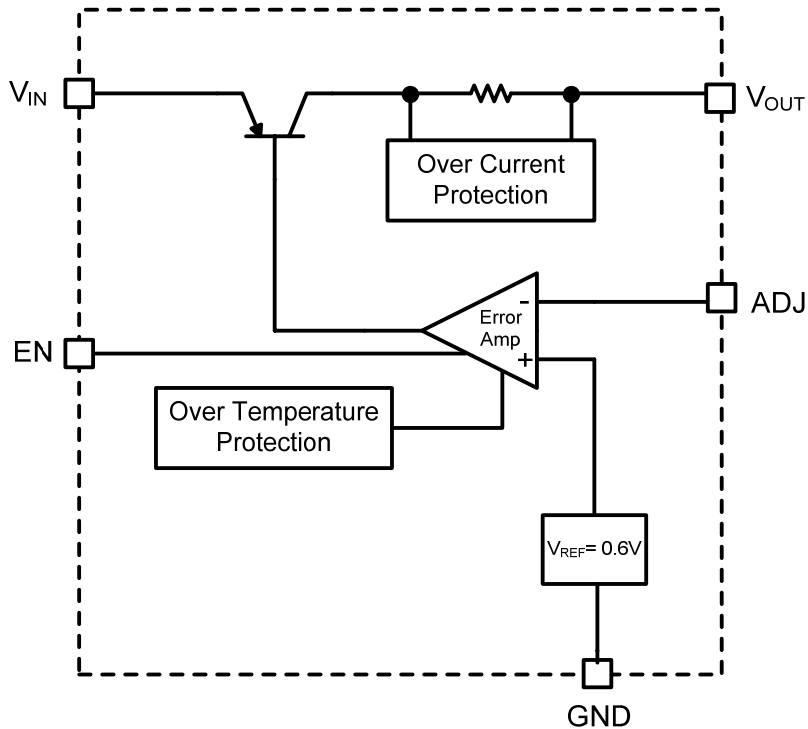

Figure 2: Block Diagram of AMS3132 5-Pin TO-263 Adjustable Voltage Option

Functional Block Diagram

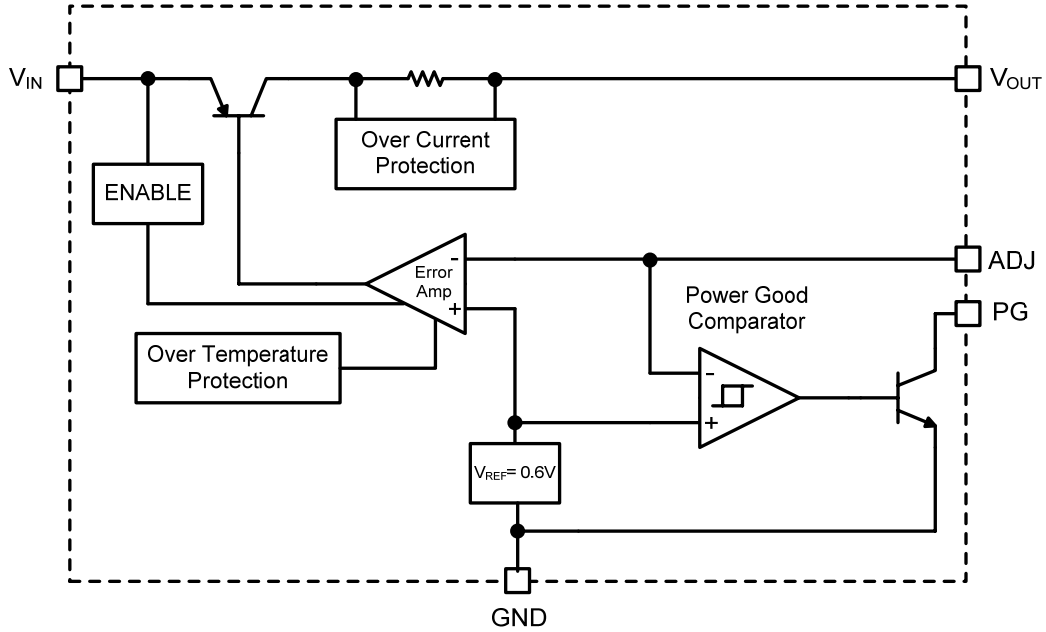

Figure 3: Block Diagram of AMS3132 5-Pin TO-263 Adjustable Voltage with Power Good Option

3A Fast Transient Linear Regulator

Device Summary

The AMS3132 is a high voltage low drop out linear regulator with a current capability of up to 3A. The LDO has a recommended operating input voltage range of 1.5V to 7V with an output voltage as low as 0.6V and is stable with a wide range of ceramic, tantalum, and electrolytic output capacitors.

Shutdown/Enable

The Enable (on/off) input threshold voltage is 1.2V. When disabled the LDO quiescent current decreases to a typical value of <1µA.

Fault Protection

Short circuit and over-temperature shutdown disable the converter and LDO in the event of an overload condition. Over-temp shutdown disables the device when the junction temperature exceeds 145 °C. The output current is internally limited to 6A typical.

Input Capacitor

An input bypass capacitor ranging from 1µF to 22µF is required. The capacitor should be placed as close as possible to the device and not be placed more than 1 inch from the LDO.

Output Capacitor

The output capacitor requirements range from the minimum value required to guarantee stability to larger values required to meet the extreme transient response requirements. Values range from 10 to 22µF X5R ceramic capacitors. Due to the extreme voltage coefficient of X5R ceramic capacitors, the voltage rating should be at least double the maximum applied voltage.

Adjustable Version: Feedback Resistor Selection

Choosing AMS3132 with adjustable output voltage option allows the user to select an output voltage by using an external resistor divider. AMS 3132 uses a 0.6V reference voltage at the positive terminal of the error amplifier. To set the output voltage a programming resistor from the adjust pin (ADJ) to ground must be selected (See Pg.1). A 10kΩ resistor is a good selection for a programming resistor R1. A higher value may result in an excessively sensitive feedback node while a lower value will draw more current and degrade the light load efficiency. The equation for selecting the voltage specific resistor is:

$$R2 = \left(\frac{V_{out}}{V_{ref}} - 1 \right) \cdot R1 = \left(\frac{5V}{0.6V} - 1 \right) \cdot 10k\Omega = 73.2k\Omega$$

Table 1: Adjustable Feedback Resistor values

Vout (V)	R2 (kΩ) (R1=10kΩ)
1.8	20.0
2.5	31.6
3.3	45.3
5.0	73.2

Power Good Version

During operation, fault conditions can occur unexpectedly. Such conditions include input voltage dropout (low V_{IN}), overheating, or overloading (excessive output current). If any of these conditions occurs, the PG pin will set an “error flag”. The PG pin, which is an open-collector output, will go LOW when V_{OUT} is less than 95% or the specified output voltage. When the voltage at V_{OUT} is greater than 95% of the specified output voltage, the PG pin is HIGH. A logic pull-up resistor of 10KΩ is recommended at this output. The pin can be left disconnected if unused.

PCB Layout

The following guidelines should be followed to insure proper layout.

1. V_{IN} Capacitor. A low ESR ceramic bypass capacitor must be placed as close to the IC as possible.
2. Adjustable (ADJ) Feedback Resistors. The adjustable feedback resistors should be placed as close as possible to the IC. Minimize the length of the trace from the feedback pin to the resistors. This is a high impedance node susceptible to interference from external RF noise sources
3. Ground.
4. For good thermal performance vias are required to couple the tab of the TO-263 package to the PCB ground plane. The via diameter should be 0.3mm to 0.33mm positioned on a 1.2mm grid.

Output Power and Thermal Limits

The AMS3132 junction temperature and current capability depends on the internal dissipation and the junction to case thermal resistance of the TO-263 exposed tab packages. Additionally, the tab paddle and PCB temperature will be elevated due to the total losses of the LDO and of other circuits mounted to the PCB.

$$T_{jmax} = P_d \cdot \theta_{jc} + T_{pcb} + T_{amb}$$

The internal losses contribute to the junction temperature rise above the paddle and PCB temperature.

3A Fast Transient Linear Regulator

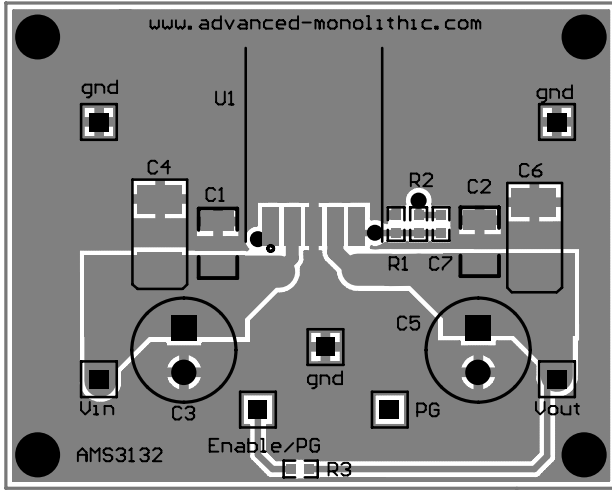

Figure 4: AMS3132 TO-263 5-Pin Evaluation Board Top Side

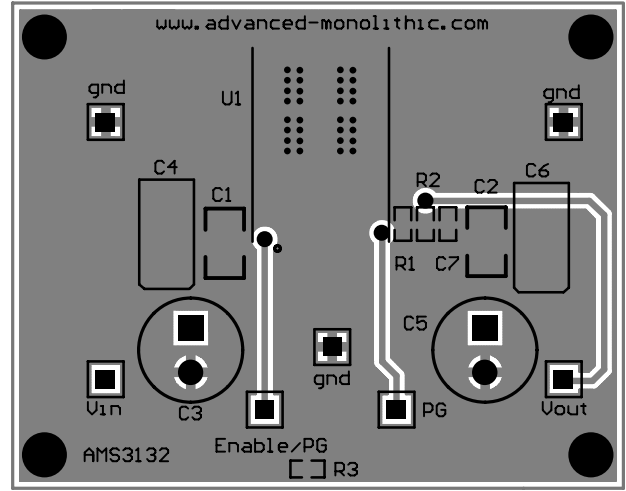

Figure 5: AMS3132 TO-263 5-Pin Evaluation Board Bottom Side

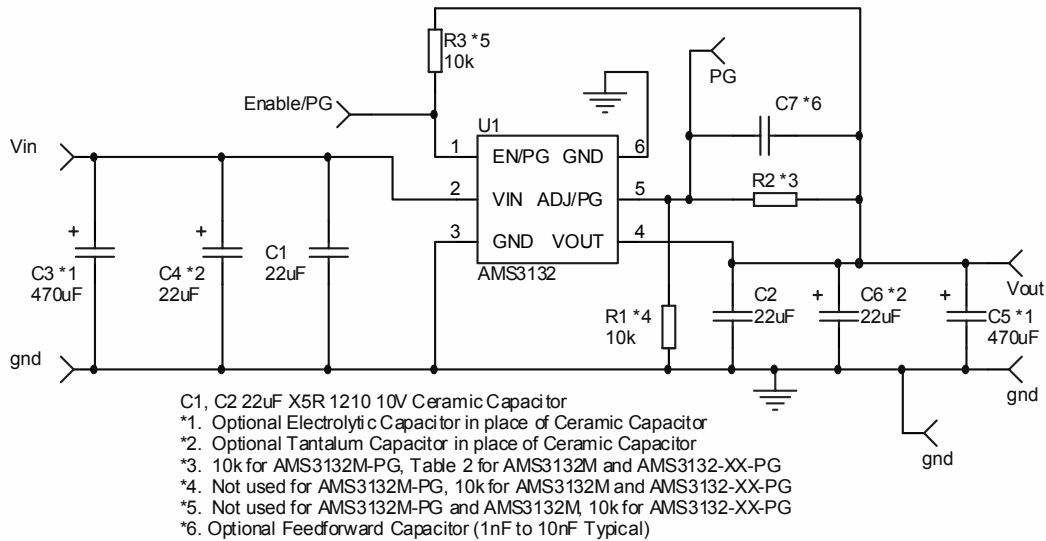

Figure 6: AMS3132 Universal Evaluation Board Schematic

Table 2: AMS3132 Universal Evaluation Board Bill of Material

Component	Value	Manufacturer	AMS3132 Version	Manufacturer Part Number
C1,C2	22μF, 10V, X5R, 0805, Ceramic	Taiyo Yuden	any	LMK212BJ226MG-T
C3,C5,C4,C6	Optional		any	
C7	Optional		any	
R1	10kΩ, 0.1W, 0603 1%	Various	AMS3132M, or AMS3132-XX-PG	CRCW060310K0FKEA
R2	See table 2	Various	AMS3132M, or AMS3132-XX-PG	CRCW0603xxKxKFKEA
	10kΩ, 0.1W, 0603 1%	Various	AMS3132M-PG	CRCW060310K0FKEA
R3	10kΩ, 0.1W, 0603 1%	Various	AMS3132-XX-PG	CRCW060310K0FKEA

Ordering Information

Device	Package
AMS3132M-XX-PG ⁽¹⁾⁽²⁾⁽³⁾	TO-263 5-Pin
AMS3132M ⁽¹⁾⁽²⁾	TO-263 5-Pin
AMS3132M-PG ⁽¹⁾⁽²⁾	TO-263 5-Pin

Notes:

1. Available in tape and reel only. A reel contains 2,500 devices.
2. Available in lead-free package only. Device is fully WEEE and RoHS compliant
3. Need to specify output voltage option ()

Outline Drawing and Landing Pattern

Package dimensions are inches (millimeters) unless otherwise noted.

