

# AMS 5915

## Amplified pressure sensor with digital output (I<sup>2</sup>C)

### FEATURES

- Calibrated and temperature compensated pressure sensor with digital output (I<sup>2</sup>C)
- Differential / relative, bidirectional differential and absolute (barometric) versions
- Digital output for pressure and temperature via I<sup>2</sup>C interface
- High accuracy at RT
- Small overall error within a temperature range of -25 .. 85 °C
- Supply voltage range 3.0 .. 3.6 V
- High long term stability
- Programmable 7 bit I<sup>2</sup>C-address
- Small DIP package
- Ready to use
- RoHS and REACH compliant

### GENERAL DESCRIPTION

AMS 5915 pressure sensors are a series of high-precision OEM sensors with a digital I<sup>2</sup>C-interface. They combine a micromachined, high quality piezoresistive measuring cell with a modern, digital signal conditioning mixed-signal CMOS-ASIC on a ceramic substrate. AMS 5915 is calibrated and compensated across a wide temperature range of -25 to +85°C.

AMS 5915 comes in a dual in-line package (DIP) for assembly on printed circuit boards (PCBs) and is fully operational without the need for any additional components. The electrical connection is made via the DIP solder pins; pressure is connected via two vertical metal tubes.

The sensors in the AMS 5915 series are available for various applications and pressure ranges: differential (relative) devices in pressure ranges from 0 .. 5 mbar up to 0 .. 10 bar, an absolute pressure variant for 0 .. 1 bar and a barometric type. Bidirectional differential devices are available in pressure ranges from -5 .. +5 mbar up to -1 .. +1 bar. Custom specific pressure ranges or modifications are available on request

### TYPICAL APPLICATIONS

- Static and dynamic pressure measurement
- Barometric pressure measurement
- Vacuum monitoring
- Gas flow
- Fluid level measurement
- Medical instrumentation
- Heating, Ventilation and Air Conditioning (HVAC)

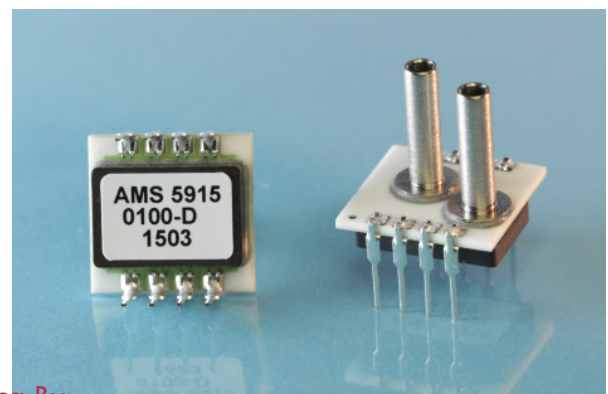

Sold in North America By:

Servoflo Corporation

75 Allen Street

Lexington, MA 02421

Tel: 781-862-9572

[www.servoflo.com](http://www.servoflo.com) / [info@servoflo.com](mailto:info@servoflo.com)

**analog microelectronics**

Analog Microelectronics GmbH  
An der Fahrt 13, D – 55124 Mainz

Phone: +49 (0)6131/91 0730-0  
Fax: +49 (0)6131/91 073-30  
Internet: [www.analogmicro.de](http://www.analogmicro.de)  
E-Mail: [info@analogmicro.de](mailto:info@analogmicro.de)

April 2015 - Rev. 2.1

# AMS 5915

## Amplified pressure sensor with digital output (I<sup>2</sup>C)

### PRESSURE RANGES

Sensor type (code)	Pressure type	Pressure range in mbar	Burst pressure <sup>1)</sup> in bar	Pressure range in PSI	Burst pressure in PSI
<b>Ultra low pressure</b>					
AMS 5915-0005-D	differential / relative	0 .. 5	> 0.35	0 .. 0.0725	> 5
AMS 5915-0010-D	differential / relative	0 .. 10	> 0.35	0 .. 0.145	> 5
AMS 5915-0005-D-B	bidirectional differential	-5 .. +5	> 0.35	-0.0725 .. +0.0725	> 5
AMS 5915-0010-D-B	bidirectional differential	-10 .. +10	> 0.35	-0.145 .. +0.145	> 5
<b>Low pressure</b>					
AMS 5915-0020-D	differential / relative	0 .. 20	> 0.5	0 .. 0.290	> 7.5
AMS 5915-0050-D	differential / relative	0 .. 50	> 1	0 .. 0.725	> 15
AMS 5915-0100-D	differential / relative	0 .. 100	> 1	0 .. 1.450	> 15
AMS 5915-0020-D-B	bidirectional differential	-20 .. +20	> 0.5	-0.290 .. +0.290	> 7.5
AMS 5915-0050-D-B	bidirectional differential	-50 .. +50	> 1	-0.725 .. +0.725	> 15
AMS 5915-0100-D-B	bidirectional differential	-100 .. +100	> 1	-1.450 .. +1.450	> 15
<b>Standard pressure</b>					
AMS 5915-0200-D	differential / relative	0 .. 200	5	0 .. 2.901	72
AMS 5915-0350-D	differential / relative	0 .. 350	5	0 .. 5.076	72
AMS 5915-1000-D	differential / relative	0 .. 1000	5	0 .. 14.50	72
AMS 5915-2000-D	differential / relative	0 .. 2000	16	0 .. 29.01	232
AMS 5915-4000-D	differential / relative	0 .. 4000	16	0 .. 58.02	232
AMS 5915-7000-D	differential / relative	0 .. 7000	16	0 .. 101.5	232
AMS 5915-10000-D	differential / relative	0 .. 10000	16	0 .. 145.0	232
AMS 5915-0200-D-B	bidirectional differential	-200 .. +200	5	-2.901 .. +2.901	72
AMS 5915-0350-D-B	bidirectional differential	-350 .. +350	5	-5.076 .. +5.076	72
AMS 5915-1000-D-B	bidirectional differential	-1000 .. +1000	5	-14.50 .. +14.50	72
AMS 5915-1000-A	absolute	0 .. 1000	5	0 .. 14.5	72
AMS 5915-1200-B	barometric	700 .. 1200	5	10.88 .. 17.4	72

**Table 1: AMS 5915 standard pressure ranges (other ranges on request)**

### MAXIMUM RATINGS

Parameter	Minimum	Typical	Maximum	Units
Maximum supply voltage: $V_{S,max}$			6.0	V
Operating temperature: $T_{op}$	-25		85	°C
Storage temperature: $T_{amb}$	-40		125	°C
Common mode pressure $p_{CM}$ <sup>2)</sup>			16	bar

**Table 2: Maximum ratings**

#### Notes:

- 1) Burst pressure is defined as the maximum pressure which may be applied to one pressure port relative to the other port (or while only one pressure port is connected) without causing leaks in the sensor.
- 2) Common mode pressure is defined as the maximum pressure, which can be applied simultaneously on both pressure ports of a differential or bidirectional transmitter without causing damages, while no differential pressure is applied.

# AMS 5915

## Amplified pressure sensor with digital output (I<sup>2</sup>C)

### SPECIFICATIONS

All parameters apply to  $V_S = 3.3\text{ V}$  and  $T_{op} = 25\text{ °C}$ , unless otherwise stated.

Parameter	Minimum	Typical	Maximum	Units
<b>Digital output signal (pressure)</b> <sup>2)</sup> @ specified minimum pressure (see "pressure range") <sup>1)</sup> @ specified maximum pressure (see "pressure range") <sup>1)</sup> Full span output (FSO) <sup>3)</sup> without pressure (bidirectional differential)		1638 14745 13107 8192		counts counts counts counts
<b>Digital output signal (temperature)</b> <sup>4)</sup> @ minimum temperature $T = -25\text{ °C}$ @ maximum temperature $T = 85\text{ °C}$		256 1382		counts counts
<b>Accuracy</b> <sup>5)</sup> (pressure measurement) @ $T = 25\text{ °C}$ Ultra low pressure sensors (5, 10 mbar) Low pressure sensors (20, 50, 100 mbar) Standard pressure sensors			$\pm 1.5$ $\pm 1.0$ $\pm 0.5$	%FSO %FSO %FSO
<b>Overall error</b> <sup>6)</sup> (pressure meas.) @ $T = -25..85\text{ °C}$ Ultra low pressure sensors (5, 10 mbar) Low pressure sensors (20, 50, 100 mbar) Standard pressure sensors			$\pm 2.0$ $\pm 1.5$ $\pm 1.0$	%FSO %FSO %FSO
<b>Total error for temperature measurement</b> All types of AMS 5915 $T = -25..85\text{ °C}$			$\pm 3.0$	%FSO
Long term stability			< 0.5	%FSO/a
Resolution A/D converter		14		bits
Resolution pressure signal		12		bits
Resolution temperature signal			11	bits
Supply voltage ( $V_S$ )		3.3		V
Overall ratiometricity error (@ $V_S = 3.0 \dots 3.6\text{ V}$ )		$\pm 0.025$	$\pm 0.1$	%FSO
Current consumption			5	mA
Reaction time (10 % .. 90 % rise time)		0.5	1	ms
Start up time (Power up to data ready)			10	ms
<b>I<sup>2</sup>C-interface</b>				
Input high level	80		100	% $V_S$
Input low level	0		20	% $V_S$
Output low level	0		10	% $V_S$
Load capacitance @ SDA			200	pF
Clock frequency SCL		100	400	kHz
Pull-up resistor	500			$\Omega$
Pressure changes	$10^6$			
Compensated temperature range	-25		85	°C
Weight		3		g
Media compatibility	See "Specification notes" <sup>7) 8)</sup>			

**Table 3: Specifications**

# AMS 5915

## Amplified pressure sensor with digital output (I<sup>2</sup>C)

### SPECIFICATION NOTES

- 1) For pressure ranges see *Table 1*
- 2) The digital output pressure signal is not ratiometric to the supply voltage.
- 3) The Full Span Output (FSO) is the algebraic difference between the output signal at the specified maximum pressure and the output signal at the specified minimum pressure (see "Pressure range").
- 4) The digital output temperature signal is not ratiometric to the supply voltage. The digital readout temperature value is the sensor temperature (including self heating).
- 5) Accuracy is defined as the maximum deviation of the measurement value from the ideal characteristic curve at room temperature (RT) in %FSO including the adjustment error (offset and span), nonlinearity, pressure hysteresis and repeatability. Nonlinearity is the measured deviation from the best fit straight line (BFSL) across the entire pressure range. Pressure hysteresis is the maximum deviation of the output value at any pressure within the specified range when the pressure is cycled to and from the minimum or maximum rated pressure. Repeatability is the maximum deviation of the output value at any pressure within the specified range after 10 pressure cycles.
- 6) The overall error is defined as the maximum deviation of the measurement value from the ideal characteristic curve in %FSO across the entire temperature range (-25 .. 85 °C).
- 7) Media compatibility of pressure port 1 (for a description of port 1, see *Figure 5*): clean, dry gases, non-corrosive to silicon, RTV silicone rubber, gold (alkaline or acidic liquids can destroy the sensor).
- 8) Media compatibility of pressure port 2 (for a description of port 2, see *Figure 5*): fluids and gases non-corrosive to silicon, Pyrex, RTV silicone rubber.

### FUNCTIONAL DESCRIPTION

The pressure sensors in the AMS 5915 series combine a high quality piezoresistive silicon sensing element with a modern mixed-signal CMOS ASIC with full digital correction for signal-conditioning on a ceramic substrate. This enables high precision measurements and excellent drift and long-term stability.

The functional principle of the AMS 5915 sensors is explained in *Figure 1*.

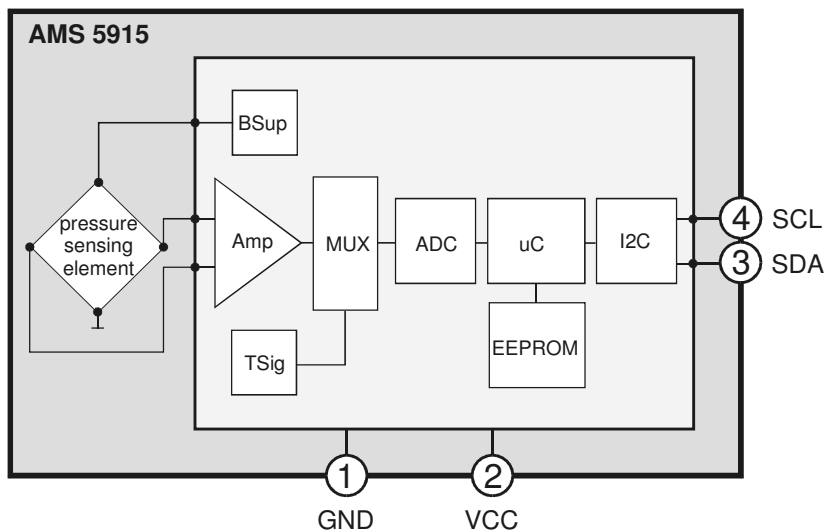

**Figure 1: Functional principle**

The physical pressure is measured at AMS 5915's piezoresistive pressure sensing element where the pressure is converted into a differential voltage signal which is almost proportional to the pressure. This differential voltage signal is corrected and conditioned by the ASIC in multiple steps.

At first the differential voltage signal from the sensing element is pre-amplified by the ASIC amplifier stage and transmitted to the A/D converter (ADC) by a multiplexer. The ADC converts this voltage signal into digital

# AMS 5915

## Amplified pressure sensor with digital output (I<sup>2</sup>C)

values with a resolution of 14 bits. The digitized signal is corrected and calibrated in the follow-on ASIC microcontroller.

During the factory calibration of AMS 5915 sensor-specific correction coefficients are determined and stored in each sensor's EEPROM. This permits sensor-specific calibration and correction (i.e. temperature compensation and linearization) of the digitized pressure signal. The temperature signal necessary for temperature compensation is generated at the ASIC temperature reference block and is transmitted by the multiplexer to the ADC, where it is digitized. The ASIC microcontroller runs a cyclic program which continuously calculates the current standardized and corrected digital pressure value using the actual digitized pressure and temperature values and the stored correction coefficients. In addition, a standardized current digital temperature value is calculated. These calculated and corrected digital values (14-bit pressure value and 11-bit temperature value) are written to the ASIC output registers and are continuously updated (typically every 0.5 ms).

The signal readout of the corrected digital pressure and temperature values is done via the I<sup>2</sup>C sensor interface at PIN3 (SDA) and PIN4 (SCL). These digital output values (for pressure and temperature) are not ratiometric to the supply voltage.

### INITIAL OPERATION

The sensors are connected up electrically by mounting them on a PCB, pins 1 to 4 have to be connected as shown in *Figure 2*.

**Important:** Each I<sup>2</sup>C-bus communication line has to be connected to the positive supply voltage (pin VCC or +3.3 V) using pull-up resistors (4.7 kΩ is recommended).

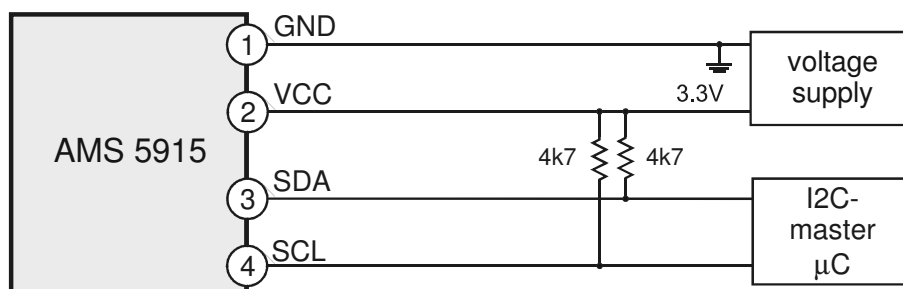

**Figure 2: Principle electric circuitry**

The pressure connection is made using the two metal pressure ports (hose connectors) on the sensor. Depending on the type of sensor and measuring pressure one or two of the pressure ports are connected up to the measuring media / volume. For the pressures at port 1 and 2 (see *Figure 5*) the following requirements have to be fulfilled (according to the definition  $p_1$  = pressure at port 1 and  $p_2$  = pressure at port 2):

Differential / relative pressure sensors:	$p_1 > p_2$
Bidirectional differential sensors:	$p_1 > p_2$ or $p_1 < p_2$ possible.
Absolute pressure sensors, barometric sensors:	$p_1$ = measuring pressure.

The guidelines on media compatibility must be taken into account here (see "Specification notes", 7 and 8).

#### Notes:

- For pressure connections up to 2 bar Analog Microelectronics recommends a silicone tubing (inner diameter  $\varnothing = 2$  mm, outer diameter  $\varnothing = 6$  mm).
- ESD precautions are necessary, it is essential to ground machines and personnel properly during assembly and handling of the device

# AMS 5915

## Amplified pressure sensor with digital output (I<sup>2</sup>C)

### I<sup>2</sup>C-INTERFACE

AMS 5915 pressure sensors have a digital output (I<sup>2</sup>C-interface). When connected to a bidirectional I<sup>2</sup>C-bus, the current corrected digital pressure and temperature values can be read from the output register of the AMS 5915 via the I<sup>2</sup>C-interface.

Communication via the I<sup>2</sup>C-bus follows a simple master-slave principle. Data transfer is always initialized by a master (such as a microcontroller, for example), which sends a data request to the sensor; the AMS 5915 sensor – which always operates as slave – answers then.

The I<sup>2</sup>C-bus requires just two bus lines: a serial data line (SDA) and a serial clock line (SDL). SDA and SCL are bidirectional lines which are connected to the positive supply voltage via pull-up resistors.

AMS 5915 communication protocol adheres to a standard I<sup>2</sup>C communication protocol (given in *Figure 3*)<sup>1</sup>.

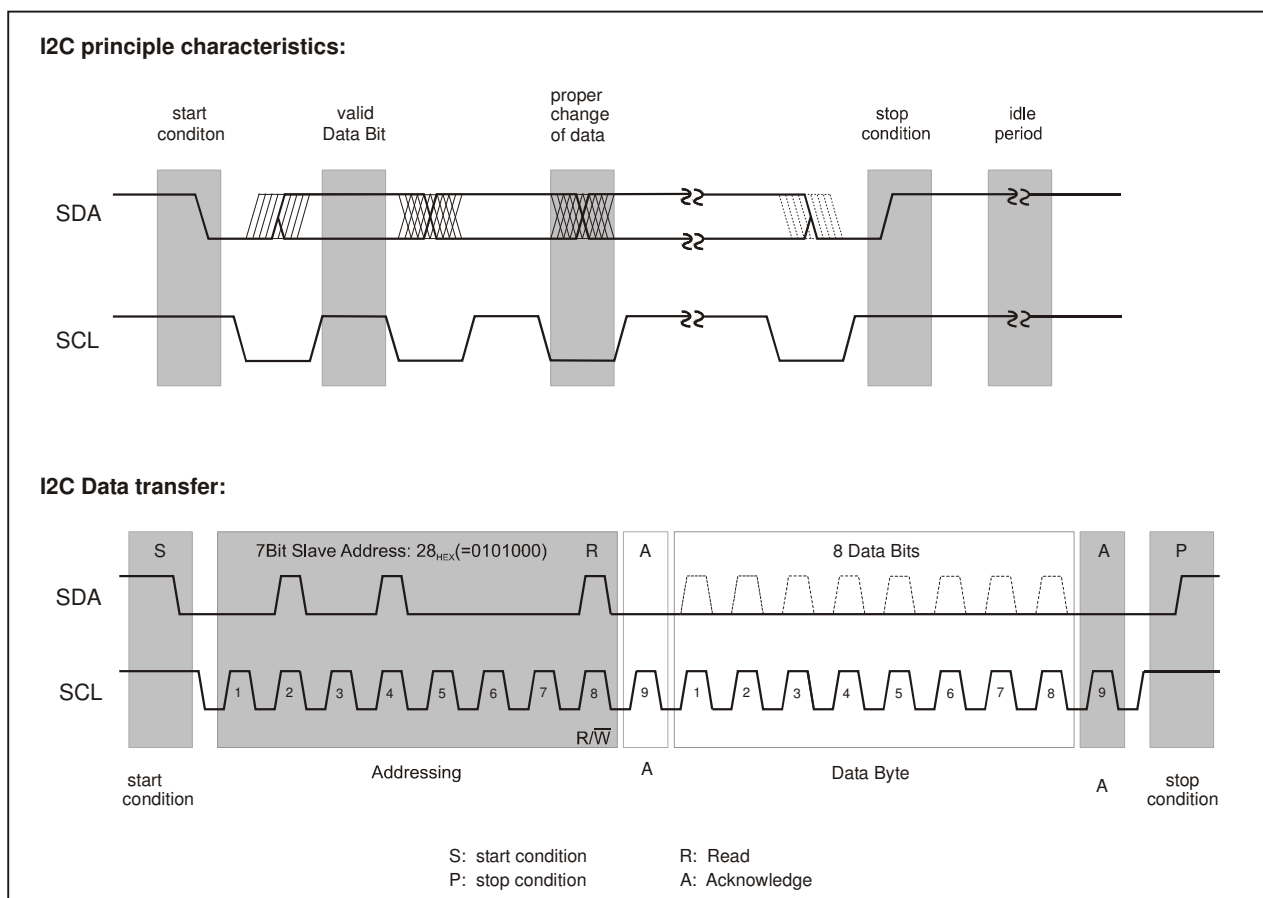

**Figure 3: Standard I<sup>2</sup>C protocol**

<sup>1</sup> There are three differences of AMS 5915 communication protocol compared to the original I<sup>2</sup>C communication protocol:

1. A stop condition directly after a start condition without no clock pulses in between is not allowed. This creates a communication error for the next communication.
2. A second start condition (restart) during data transmission when SCL is still high is not allowed.
3. Between the start condition and the first rising SCL edge a falling SDA edge is not allowed.

# AMS 5915

## Amplified pressure sensor with digital output (I<sup>2</sup>C)

The I<sup>2</sup>C communication phases are as follows:

### Idle period (bus is free)

When the bus is free, both I<sup>2</sup>C-bus lines (SDA and SCL) are pulled up to supply voltage level ("high level").

### Start S (start condition)

Prior to any data transfer on the bus a start condition must be generated. The start condition is always sent by the I<sup>2</sup>C-master. The start condition is defined as a transition from "high level" to "low level" on the SDA line while the SCL line is still on "high level". The digital data readout from the AMS 5915 is always initiated by a start condition.

### Stop P (stop condition)

The stop condition is always generated by the I<sup>2</sup>C-master after a data transfer has been completed. The stop condition is defined as a transition from "low level" to "high level" on the SDA line while the SCL line is still on "high level". The digital data readout from the AMS 5915 is always terminated by a stop condition.

### Valid data

Data is transmitted in bytes (8 bits), starting with the most significant bit (MSB). One data bit is transmitted with each clock pulse. The transmitted bits are only valid when, following a start condition, the level on the SDA line is constant as long as the SCL line is on "high level". Changes to the SDA level must be made while the SCL line is on "low level".

### Acknowledge A

After a byte has been transmitted the respective receiver (master or slave) has to send an acknowledge (additional acknowledge bit) confirming the correct receipt of the data. To this end the master generates an extra acknowledge-related clock pulse. The receiver sends the acknowledge bit by pulling the SDA line down to "low level" during the additional clock pulse.

### Addressing / Slave address (I<sup>2</sup>C-address AMS 5915)

After the start condition the master sends an addressing byte (the first byte after the start condition) which determines which slave is selected. The addressing byte contains the individual 7-bit slave address of the selected slave (AMS 5915) and a data direction bit ( $\overline{R/W}$ ). An "0" for the  $\overline{R/W}$  bit indicates a transmission from master to slave (W: write; the master wishes to transmit data to the selected slave), a "1" a data request (R: read; the master requests data from the slave).

The pressure sensors in the AMS 5915 series have a standard, factory-programmed 7-bit slave address of 0x28<sub>Hex</sub> (0101000<sub>bin</sub>).

If more than one AMS 5915 should be connected to the same I<sup>2</sup>C-bus, each pressure sensor requires an individual slave address. On request each AMS 5915 can be ordered with an individual 7-bit slave address programmed at the factory; 7-bit addressing allows 128 different addresses. Using the AMS 5915's USB starter kit the customer can programm the individual slave address himself.

# AMS 5915

## Amplified pressure sensor with digital output (I<sup>2</sup>C)

### DATA READOUT VIA THE I<sup>2</sup>C-INTERFACE

The digital output values for pressure (14-bit value) and temperature (11-bit value) are read out from the AMS 5915 output register via the AMS 5915 I<sup>2</sup>C-interface. The data readout, which is illustrated in *Figure 4*, is done byte per byte.

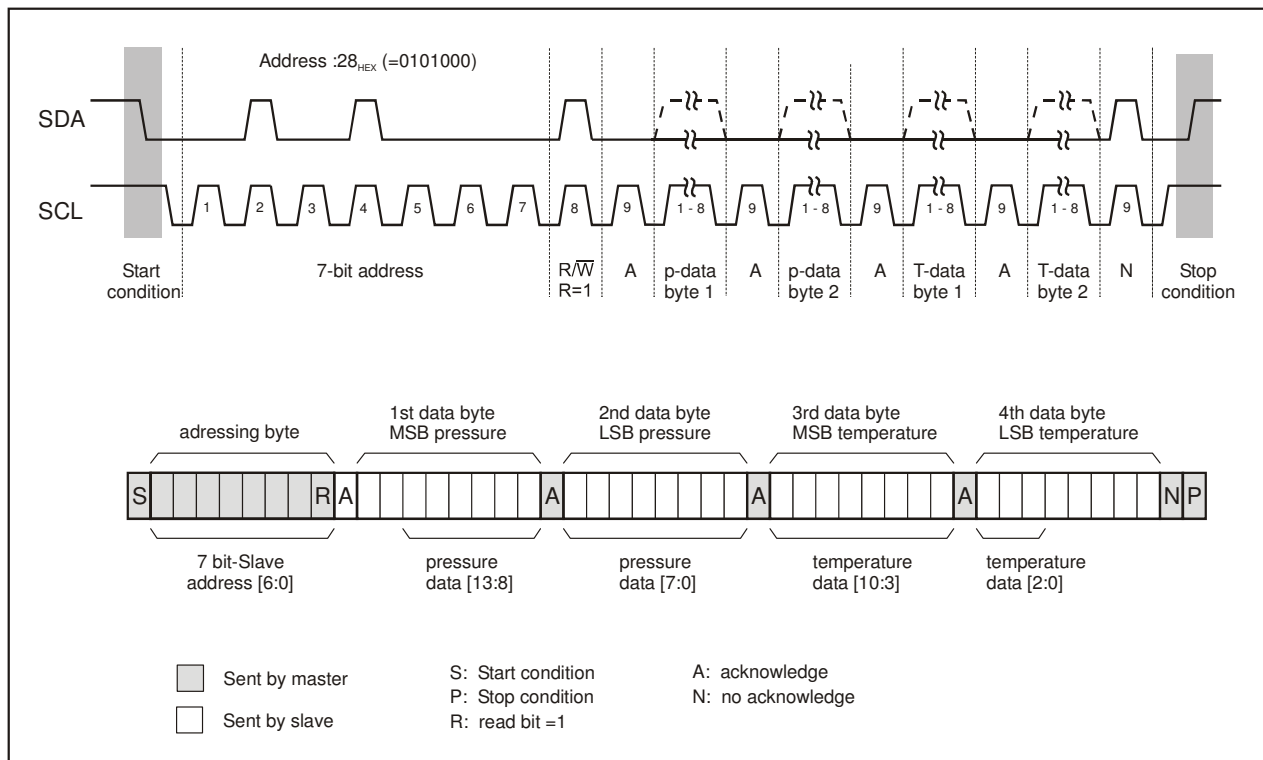

**Figure 4: Data readout of the digital pressure and temperature values**

Data transfer via the I<sup>2</sup>C-bus is always initialized by a data request from the I<sup>2</sup>C-master. For this purpose the I<sup>2</sup>C-master generates a start condition on the I<sup>2</sup>C-bus lines. Following the start condition the I<sup>2</sup>C-master then sends the addressing byte containing the 7-bit slave address of the AMS 5915 (programmed to 0x28<sub>Hex</sub> = 0101000<sub>bin</sub> at the factory) and the data direction bit R = 1 which indicates a data request. The selected pressure sensor first answers with an acknowledge bit. The selected sensor then starts the data transfer from the output register.

For pressure and temperature value readout a total of four data bytes are transmitted from the pressure sensor to the I<sup>2</sup>C-master. The two bytes for the current digital pressure value are first sent, followed by the two bytes for the current digital temperature value, always beginning with the most significant byte. On each transferred data byte the I<sup>2</sup>C-master sends an acknowledge bit confirming the correct receipt of data. After the 4<sup>th</sup> data byte, the receiving master generates a no acknowledge bit; the pressure sensor is set to inactive. The I<sup>2</sup>C-master shuts down the data transfer by sending a stop condition.

The 14-bit pressure value is given by the last 6 bits of the 1<sup>st</sup> data byte and the 8 bits of the 2<sup>nd</sup> data byte always beginning with the most significant bit. The 11-bit temperature value is given by the 8 bits of the 3<sup>rd</sup> data byte and the first 3 bits of the 4<sup>th</sup> data byte.

For pressure value readout only it is possible to stop the data transfer after two data bytes. In this case the I<sup>2</sup>C-master sends a no acknowledge bit after the 2<sup>nd</sup> data byte and shuts down the data transfer by sending a stop condition.



# AMS 5915

## Amplified pressure sensor with digital output (I<sup>2</sup>C)

### Calculating the current pressure and temperature value

The digital output values for pressure (14-bit value) and temperature (11-bit value) have to be converted in order to generate the desired information on pressure and temperature in physical units.

The current pressure in bar (or PSI) is calculated from the digital pressure value using the following formulas:

$$p = \frac{Digoutp(p) - Digoutp_{min}}{Sensp} + p_{min} \quad \text{with} \quad Sensp = \frac{Digoutp_{max} - Digoutp_{min}}{p_{max} - p_{min}} \quad (1)$$

Therein  $p$  is the current pressure in bar (or PSI),  $p_{min}$  is the specified minimum pressure and  $p_{max}$  is the specified maximum pressure in bar (or PSI); depending on the specified pressure range,  $Digoutp(p)$  is the current digital 14-bit pressure value in counts,  $Digoutp_{min}$  and  $Digoutp_{max}$  are the digital pressure values at minimum and maximum specified pressure in counts and  $Sensp$  is the sensitivity of the pressure sensor in counts/bar (or counts/PSI).

The current sensor temperature in °C is calculated from the digital temperature value using the following formula:

$$T = \frac{DigoutT(T) * 200}{2048} - 50 \quad \text{in } ^\circ\text{C} \quad (2)$$

Therein  $T$  is the current sensor temperature in °C and  $DigoutT(T)$  is the current 11-bit digital temperature value in counts.

### Example

At the digital output of an AMS 5915-0005-D-B (-5 .. 5 mbar bidirectional differential sensor) the following data bytes 1 .. 4 are read:

Byte 1: 00101100      Byte 2: 11001101      Byte 3: 01011100      Byte 4: 11100000

Taking the last 14 bits of byte 1 and byte 2 the current 14 bit digital pressure value is:

$$Digoutp(p) = 10110011001101_{bin} \text{ counts} = 2CCD_{Hex} \text{ counts} = 11469_{Dec} \text{ counts}$$

and with the first 11 bits of byte 3 and byte 4 the digital temperature value is:

$$DigoutT(T) = 01011100111_{bin} \text{ counts} = 2E7_{Hex} \text{ counts} = 743_{Dec} \text{ counts} .$$

With  $p_{min} = -5$  mbar,  $p_{max} = 5$  mbar and  $Digoutp_{min} = 1638$ ,  $Digoutp_{max} = 14745$  specified for AMS 5915-0005-D-B the current pressure in mbar is calculated using formula (1) as:

$$p = \frac{(11469 - 1638) \text{ counts}}{(13107 / 10) \text{ counts/mbar}} + (-5) \text{ mbar} = 2.501 \text{ mbar}$$

Using formula (2), the current sensor temperature in °C is calculated as:

$$T = \frac{(743 * 200) \text{ counts} * ^\circ\text{C}}{2048 \text{ counts}} - 50 \text{ } ^\circ\text{C} = 22.6 \text{ } ^\circ\text{C}$$

# AMS 5915

## Amplified pressure sensor with digital output (I<sup>2</sup>C)

### DIMENSIONS AND PINOUT

AMS 5915 pressure sensors come in a dual-in-line package (DIP) for assembly on printed circuit boards (PCB).

Figure 5 below gives the pinout and dimensions of the dual-in-line package.

#### Pin-Out and pressure connection:

##### differential types:

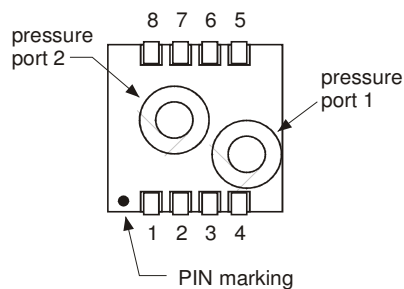

##### absolute, barometric types:

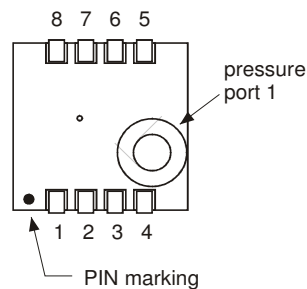

Pin	Description
1	GND.
2	VCC
3	SDA
4	SCL
5	N.C.
6	N.C.
7	N.C.
8	N.C.

#### Package Dimensions:

##### Side view :

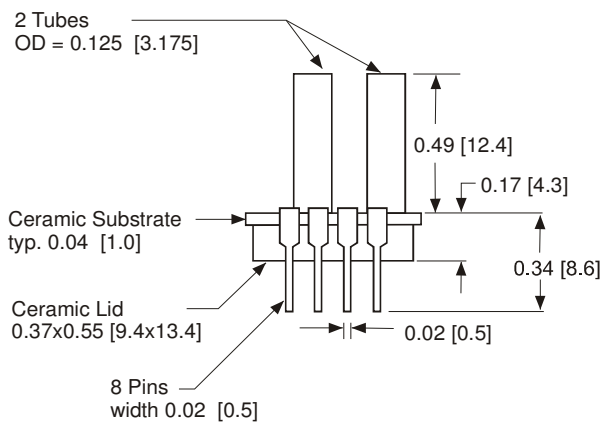

##### Top view :

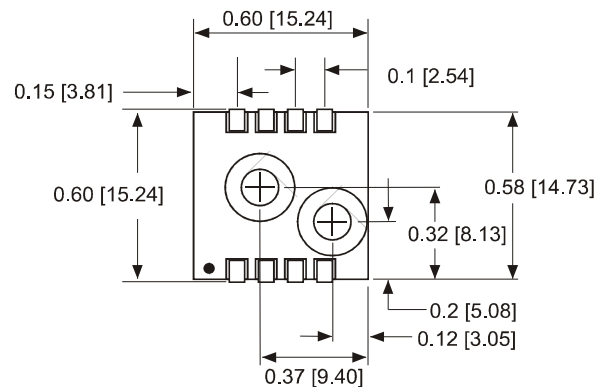

all Dimensions in inch [mm]

Figure 5: Dimensions

All sensors in the AMS 5915 series are maintenance free during their lifetime.

#### Notes:

1. A package without tubes (for O-ring sealing) is also available.
2. SMD Pins are available on request

# AMS 5915

## Amplified pressure sensor with digital output (I<sup>2</sup>C)

### INFORMATION FOR ORDERING

Ordering code:

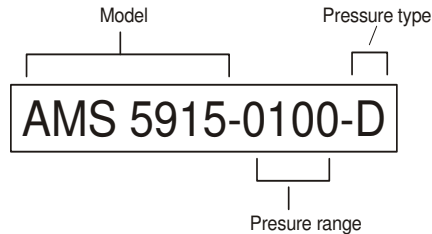

Pressure range:

Pressure range code	mbar	PSI	kPa
0005	5	0.073	0.5
0010	10	0.145	1.0
0020	20	0.290	2.0
0050	50	0.725	5.0
0100	100	1.450	10
0200	200	2.901	20
0350	350	5.076	35
1000	1000	14.50	100
1200	1200	17.40	120
2000	2000	29.01	200
4000	4000	58.02	400
7000	7000	101.5	700
10000	10000	145.0	1000

Table 4: Pressure ranges

Pressure type:

Pressure type code	Available pressure ranges
D differential / relative (gage)	0 .. 5 mbar to 0 .. 10 bar
D-B bidirectional differential	-5 .. +5 mbar to -1 .. 1 bar
A absolute	0 .. 1000 mbar
B barometric (absolute)	700 .. 1200 mbar

Table 5: Pressure types

### ADDITIONAL EQUIPMENT

A USB starter kit with software is available for AMS 5915 sensors. This kit permits easy readout of the digital pressure and temperature values using a standard PC. Furthermore, the starter kit can be used to set a permanent individual I<sup>2</sup>C slave address for a particular AMS 5915 sensor, allowing the readout of multiple sensors via the same I<sup>2</sup>C-bus.

Ordering code	Description
USB starter kit AMS 5915	AMS 5915 - starter kit (2 PCBs with software)

# AMS 5915

Amplified pressure sensor with digital output (I<sup>2</sup>C)

## NOTES

Analog Microelectronics GmbH reserves the right to amend any dimensions, technical data or other information contained herein without prior notification.

---