

DOCUMENT COVER PAGE

APPROVED
EXTERNAL ISSUE

Note: This cover page establishes the Doc No., Title and current status of the attached document.

Doc No.	SDSC-PSE-AN17832A	Issue Level	Rev	Eff Date
		1	0	24-Nov-05
Doc Title	Product Specifications for AN17832A	Total no. of pages (excluding this page)		14

Revision History

Issue	Rev	Eff Date	S/N	Page	Change Details	Remarks
1	0	24-Nov-05			First issue	

Code No.:

APPROVED
Total Pages 14 Page 1
EXTERNAL ISSUE

Product Standards

Part No.	AN17832A
Package Code No.	HSIP012-P-0000E

Analogue LSI Business Unit
Semiconductor Company
Matsushita Electric Industrial Co., Ltd.

Established by	Applied by	Checked by	Prepared by
	<i>M. Hiramatsu</i>	<i>Law</i>	<i>Yuan</i>
S. OKADA	M.HIRAMATSU	KENNETH LAW	WOONG C Y

2005-11-24

Established

Revised

	Product Standards	APPROVED AN17832A	
		EXTERNAL ISSUE	
		Total Pages	Page
		14	2

Contents

■ Overview	3
■ Features	3
■ Applications	3
■ Package	3
■ Type	3
■ Application Circuit Example	4
■ Block Diagram	5
■ Pin Descriptions	5
■ Absolute Maximum Ratings	6
■ Operating Supply Voltage Range	6
■ Electrical Characteristics	7
■ Test Circuit Diagram	8
■ Technical Data	9
• I/O block circuit diagrams and pin function descriptions	9
■ Usage Notes	13

2005-11-24		For Kong Tak Electronics Co. Ltd.
Established	Revised	

	Product Standards	APPROVED AN17832A	
		EXTERNAL ISSUE	
		Total Pages	Page
		14	3

AN17832A

A dual channel OCL and single channel BTL audio power amplifier IC

■ Overview

AN17832A is a monolithic integrated circuit designed for 15W X 2 (4Ω) and 30W X 1 (8Ω) outputs audio power amplifier. It is a dual channel OCL and single channel BTL IC suitable for operation in audio application. It has built-in Standby and Muting functions.

■ Features

1. Few external components –no negative feedback capacitors.
2. Built-in Standby/Mute circuit.
3. Built-in Thermal Protection circuit.
4. High ripple rejection.
5. Operating voltage range from $\pm 5V \sim \pm 15V$ ($\pm 12V$ typ.)

■ Applications

- IC for audio applications

■ Package

- 12 pin Plastic Single Inline Package With Heat Sink (SIP Type)

■ Type

- Silicon Monolithic Bipolar IC

2005-11-24		For Kong Tak Electronics Co. Ltd.
Established	Revised	

Product Standards

Total Pages	Page
14	4

■ Application Circuit Example

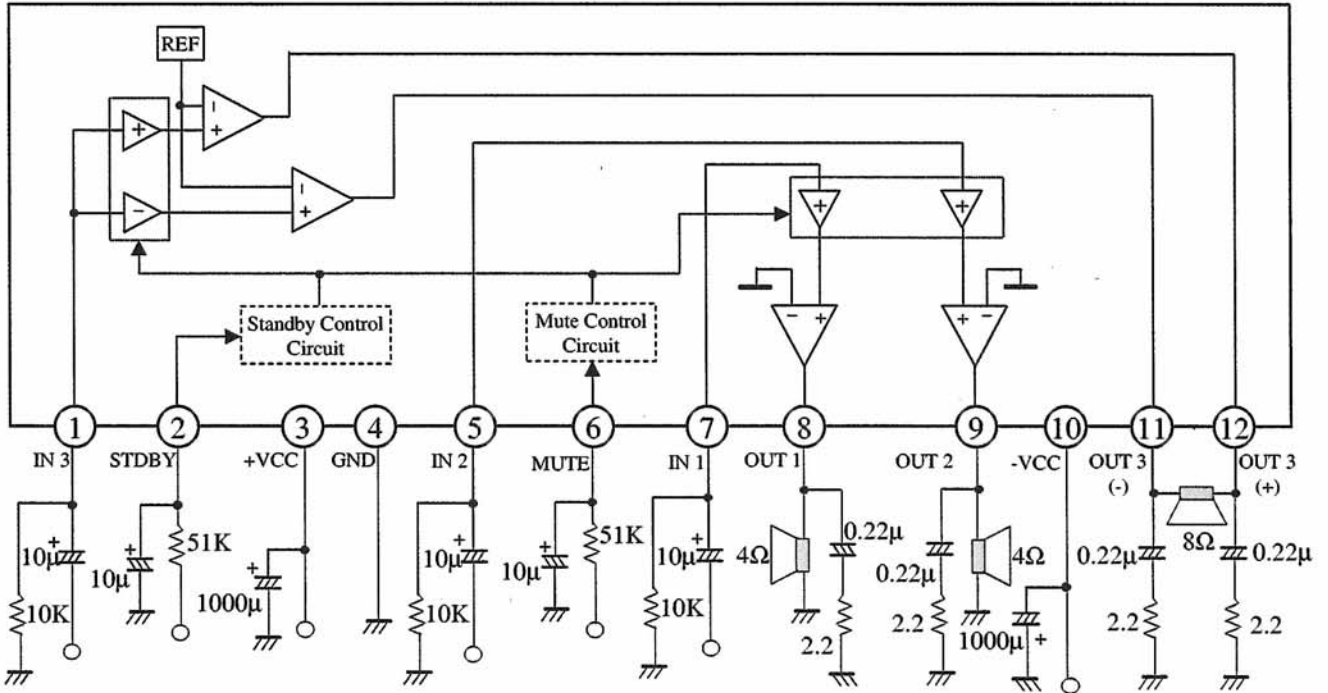

2005-11-24		For Kong Tak Electronics Co. Ltd.
Established	Revised	

■ Block Diagram

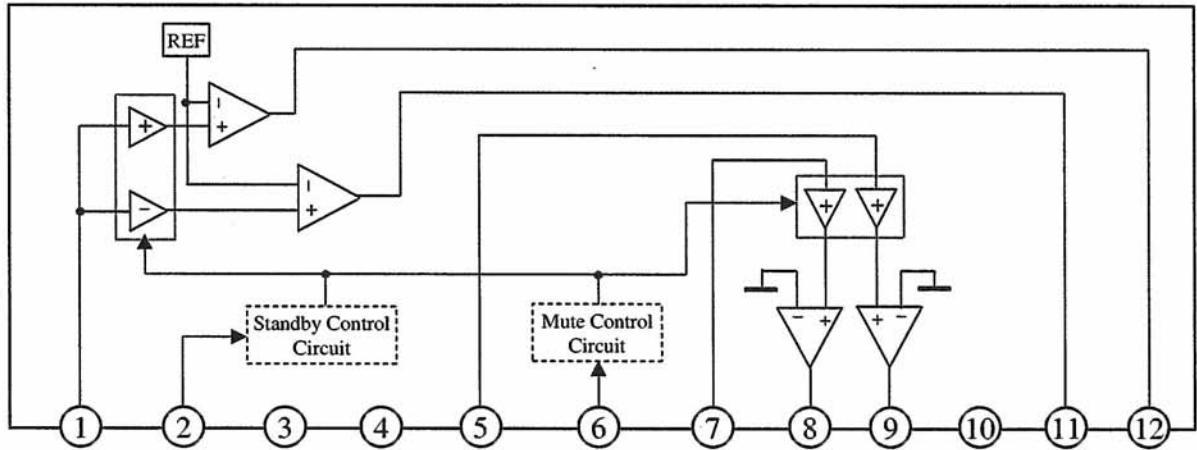

■ Pin Descriptions

Pin No.	Pin name	Type	Description
1	IN3	Input	Channel 3 input
2	STDBY	Input	Standby control
3	+VCC	Input	Positive Power Supply
4	GND	Ground	Ground
5	IN2	Input	Channel 2 input
6	MUTE	Input	Mute Control
7	IN1	Input	Channel 1 input
8	OUT1	Output	Channel 1 output
9	OUT2	Output	Channel 2 output
10	-VCC	Input	Negative Power Supply
11	OUT3(-)	Output	Channel 3 negative phase output
12	OUT3(+)	Output	Channel 3 positive phase output

■ Absolute Maximum Ratings

A No.	Parameter	Symbol	Rating	Unit	Note
1	Supply voltage	V_{CC}	± 17.0	V	*1
2	Supply current	I_{CC}	11.0	A	
3	Power dissipation	P_D	1.8	W	*2
4	Operating ambient temperature	T_{opr}	-20 to +75	°C	*3
5	Storage temperature	T_{stg}	-55 to +150	°C	*3

Note) *1: The values under the condition not exceeding the above absolute maximum ratings and the power dissipation.

*2: The power dissipation shown is the value at $T_a = 75^\circ\text{C}$ for the independent IC package without a heat sink.

When using this IC, refer to the PD-Ta diagram of the package standard and use under the condition not exceeding the allowable value.

*3: Except for the operating ambient temperature and storage temperature, all ratings are for $T_a = 25^\circ\text{C}$.

■ Operating supply voltage range

Parameter	Symbol	Range	Unit	Note
Positive supply voltage range	$+V_{CC}$	5.0 to 15.0	V	—
Negative supply voltage range	$-V_{CC}$	-5.0 to -15.0	V	—

■ Electrical Characteristics at Vcc = ±12V, Vstb = 5V, Mute = 0V, RL (BTL) = 8Ω, RL (OCL) = 4Ω, freq = 1KHz unless otherwise specified. (Note: T_a = 25°C±2°C unless otherwise specified.)

B No.	Parameter	Symbol	Test circuits	Conditions	Limits			Unit	Note
					Min	Typ	Max		
1	Quiescent Circuit Current	I _{CCQ}	1	Vin=0mV	-	100	300	mA	
2	Standby Current	I _{STB}	1	Vin=0mV	-	1	10	μA	
3	Output Noise Voltage 1 (BTL)	Vno1	1	Vin=0mV	-	0.3	0.5	mVrms	1
4	Output Noise Voltage 2 (OCL)	Vno2	1	Vin=0mV	-	0.15	0.3	mVrms	1
5	Standby On Voltage	Vstb-on	1	I _{STB} ≤ 10uA	0	-	1.0	V	
6	Standby Off Voltage	Vstb-off	1	No Input	3.0	-	5.0	V	
7	Mute On Voltage	Mute-on	1	Muting Ratio ≥ 60dB	3.0	-	5.0	V	
8	Mute Off Voltage	Mute-off	1	G _{V1} ≥ 38dB G _{V2} ≥ 32dB	0	-	1.0	V	
[BTL Channel]									
9	Voltage Gain 1	G _{V1}	1	Vin=20mV	36	38	40	dB	
10	Total Harmonic Distortion 1	THD1	1	Vin=20mV	-	0.1	0.4	%	
11	Maximum Output Power 1	Po1	1	THD=10%	25	30	-	W	
12	Channel Crosstalk 1	CT1	1	Vin=20mV	50	60	-	dB	
13	Output Offset Voltage	Voff	1	No Input	-350	0	350	mV	
14	Ripple Rejection 1	RR1	1	f _r =100Hz, V _r = 0.5Vrms	45	55	-	dB	1
15	Muting Ratio 1	MR1	1	Mute = 3V	60	70	-	dB	
[OCL Channel]									
16	Voltage Gain 2	G _{V2}	1	Vin=57mV	32	34	36	dB	
17	Total Harmonic Distortion 2	THD2	1	Vin=57mV	-	0.1	0.4	%	
18	Maximum Output Power 2	Po2	1	THD=10%	12	15	-	W	
19	Channel Balance	CB	1	Vin=57mV	-1	0	1	dB	
20	Channel Crosstalk 2	CT2	1	Vin=57mV	50	60	-	dB	
21	Ripple Rejection 2	RR2	1	f _r =100Hz, V _r = 0.5Vrms	45	55	-	dB	1
22	Muting Ratio 2	MR2	1	Mute = 3V	60	70	-	dB	

Note) *1: For this measurement, use the 20Hz - 20kHz (12dB/OCT) filter.

2005-11-24		For Kong Tak Electronics Co. Ltd.
Established	Revised	

APPROVED
EXTERNAL ISSUE

■ Test Circuit Diagram

Test Circuit 1

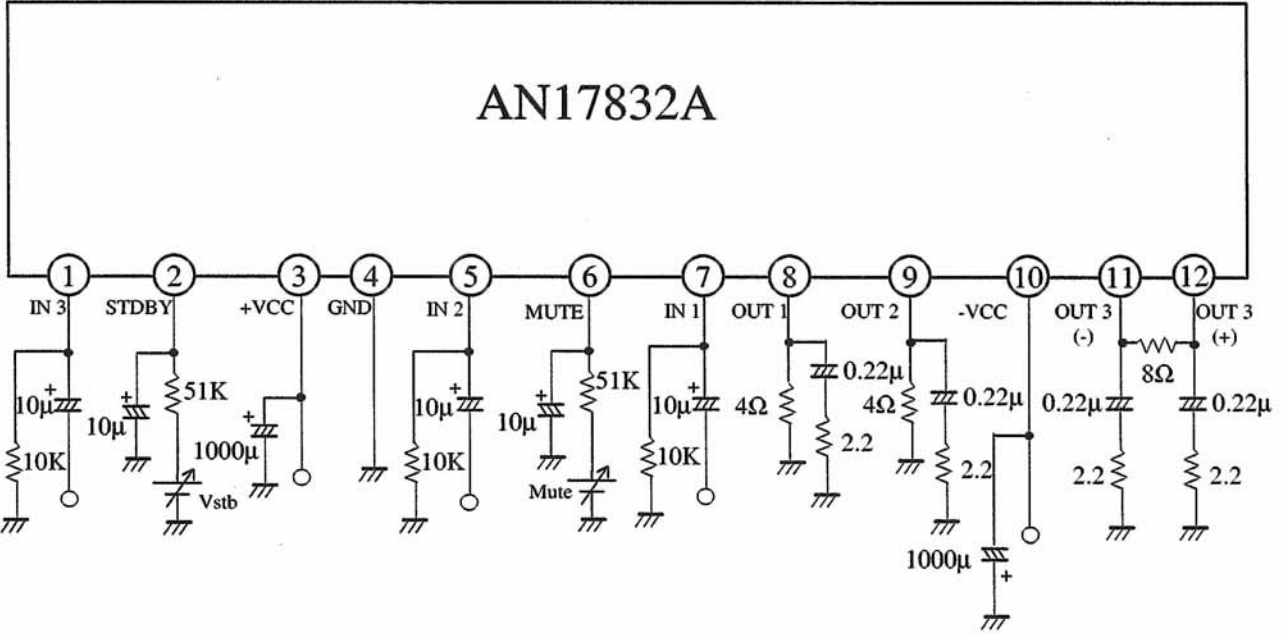

2005-11-24	
Established	Revised

For Kong Tak Electronics Co. Ltd.

■ Technical Data

1. I/O block circuit diagrams and pin function descriptions

Note) The characteristics listed below are reference values based on the IC design and are not guaranteed.

Pin No.	Internal circuit	Description
1		Channel 3 BTL Input
2		Standby Control Pin
3	-	VCC
4	-	Ground

■ Technical Data

1. I/O block circuit diagrams and pin function descriptions

Note) The characteristics listed below are reference values based on the IC design and are not guaranteed.

Pin No.	Internal circuit	Description
5		Channel 2 OCL Input
6		Mute Control
7		Channel 1 OCL Input

Product Standards		APPROVED	
		Total Pages	Page
		14	11

■ Technical Data

1. I/O block circuit diagrams and pin function descriptions

Note) The characteristics listed below are reference values based on the IC design and are not guaranteed.

Pin No.	Internal circuit	Description
8		Channel 1 OCL Output
9		Channel 2 OCL Output
10		-VCC

2005-11-24		For Kong Tak Electronics Co. Ltd.
Established	Revised	

■ Technical Data

1. I/O block circuit diagrams and pin function descriptions

Note) The characteristics listed below are reference values based on the IC design and are not guaranteed.

Pin No.	Internal circuit	Description
11		Channel 3 negative phase output
12		Channel 3 positive phase output

	Product Standards	APPROVED	
		Total Pages	Flags
		14	13

■ Usage Notes

1. Carry out the thermal design with sufficient margin such that the power dissipation will not be exceeded under the necessary conditions of power supply voltage, load impedance and ambient temperature.
2. The protection circuit is for maintaining safety against an abnormal operation. Therefore, design the protection circuit such that it should not operate during normal operation. Especially for the over-temperature protection circuit, if the area of safe operation or the absolute maximum rating is momentarily exceeded by output pin to VCC short, or output pin to GND short (Ground fault), the LSI might be damaged before the over-temperature protection circuit starts working.
3. Pay attention to the PCB(Printed-Circuit-Board) pattern layout in order to prevent damage due to short circuit between pins. In addition, for the pin configuration, refer to the pin functional description diagram (Sheet No. 9 ~ 11).
4. Unless specified in the product specifications, make sure that negative voltage or excessive voltage are not applied to the pins because the device might be damaged, which could happen due to negative voltage or excessive voltage generated during the ON and OFF timing when the inductive load of a motor coil or actuator coils of optical pick-up is being driven.
5. Do not mount the LSI in the reverse direction onto the PCB(Printed-Circuit-Board) and pin shift. It might be damaged when power is applied.
6. Carry out visual inspection on the PCB(Printed-Circuit-Board) before applying the power, otherwise damage might happen due to problems such as solder-bridge between the pins of the semiconductor device. Also, perform a full technical verification on the assembly quality, because the same damage may happen due to conductive substances, such as solder ball, that adhere to the LSI during transportation.
7. Take notice in the use of this product that it might be damaged or occasionally emit smoke when an abnormal state occurs such as output pin-VCC short, output pin-GND short, output-to-output-pin short (load short) , or pin to pin leakage current . (And, safety measures such as an installation of fuses are recommended because the extent of the above- mentioned damage and smoke emission will depend on the current capability of the power supply.)
8. When carrying out derivative product expansion or when the product is going to be used in a new set, verify the safety including the long-term reliability for each set.
9. Check the risk that is caused by the failure of external components.
10. Ground the radiation fin so that there will be no difference in electric potential between the radiation fin and ground.
11. The thermal protection circuit operates at a Tj of approximately 150°C. The thermal protection circuit is reset automatically when the temperature drops.
12. For installation to heat-sink, grease for heat-sink should be applied to reduce the contact heat resistance and increase the radiating effect. Ensure that there is no foreign objects between IC and heat-sink which may cause cracks and additional stress to the IC.

2005-11-24		For Kong Tak Electronics Co. Ltd.
Established	Revised	

	Product Standards	APPROVED	
		EXTERNAL ISSUE	
		Total Pages	Page
		14	14

■ Usage Notes

13. The IC should be mounted onto a flat-surfaced heat-sink first, in a manner where little stress is applied, then solder the leads of the IC to the board.
14. If the tightening torque of the heat-sink is too low, the heat resistance will become large. If it is too high, the physical device will be distorted which might result in a failure. The tightening torque recommended is 78.5N.cm.
15. Fasten the heat-sink firmly on the chassis or board. Do not create a structure where the heat-sink is supported by the IC.
16. In the event of abnormal operation condition whereby the output terminals swing towards supply/ground, the destruction of the speaker may result. As such, please ensure that the rating of the speaker is appropriate and made of non-flammable material.
17. Both +VCC and -VCC must operate at the same time and before standby turns off.
18. The Input pin of this product is necessary to be tied to ground through a resistor as it has significant effect on the output offset and the supply surge susceptibility.
19. The power supply pin of this product is necessary to be tied to ground through a capacitor as it has significant effect on the supply surge susceptibility.

2005-11-24		For Kong Tak Electronics Co. Ltd.
Established	Revised	