

Minimizing component numbers allows downsizing equipment.

Radio Tuner IC for Home Stereos AN18200A

■ Overview

The AN18200A radio tuner IC for home stereos incorporates a sound detection circuit for the FM IF, FM-MPX, AM RF and AM bands. Also incorporating an FM/AM synthesizer with a prescaler, the AN18200A is suitable for use in virtually any audio tuner application.

■ Feature

- AM RF + MIX + L-OSC, FM/AM IF + DET, FM-MPX, PLL
- I²C buss control
- Built-in 19kHz pilot signal cancellation + anti-birdie function
- FM detection coil unnecessary
- Stereo reception non-adjustment
- Built-in post amplifier

■ Applications

Radio tuners for component and mini-component systems

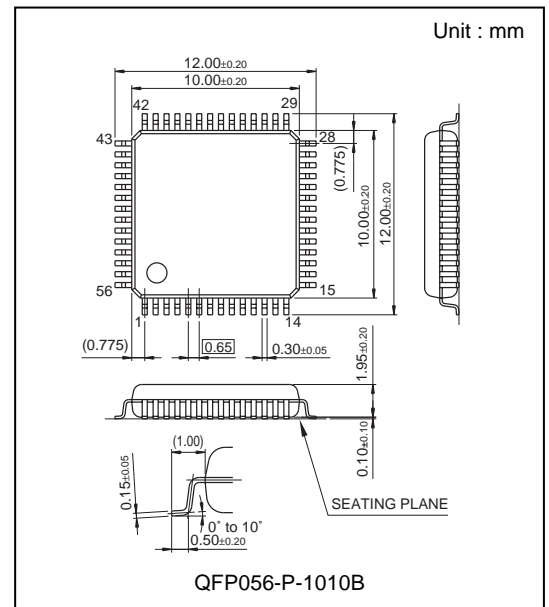

■ Block Diagram

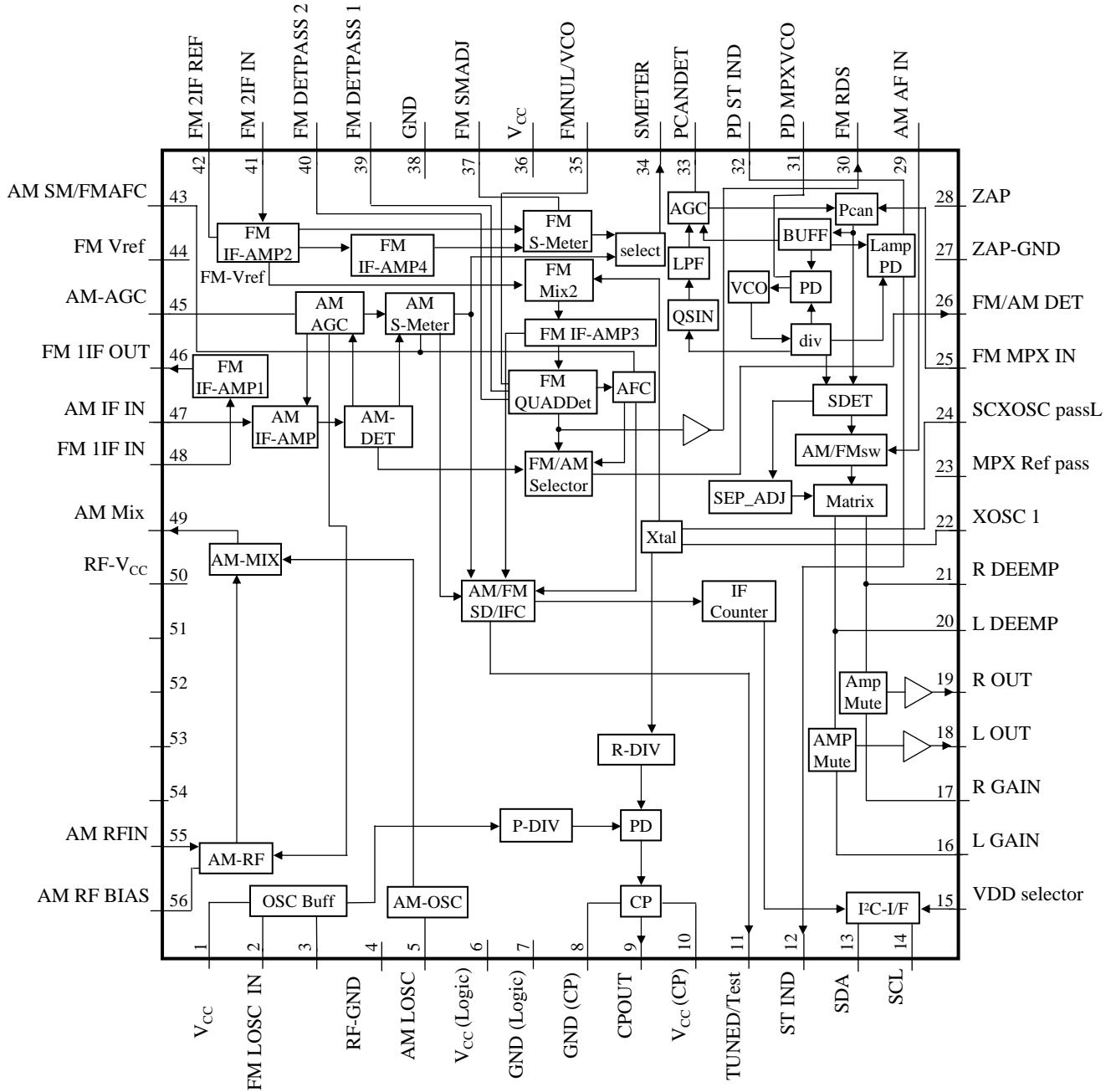

■ Pin Descriptions

Pin No.	Pin name	Type	Description
1	V _{CC} (FM LOSC)	IN	V _{CC} for FM local oscillator
2	FM LOSC 1	IN	FM local oscillator load 1
3	FM LOSC 2	OUT	FM local oscillator load 2
4	RF-GND	IN	RF-GND
5	AM LOSC	IN/OUT	AM local oscillator load
6	V _{CC} (Logic)	IN	Logic-V _{CC}
7	GND(Logic)	IN	Logic-GND
8	GND(CP)	IN	Charge pump-GND
9	CPOUT	OUT	Charge pump output
10	V _{CC} (CP)	IN	Charge pump-V _{CC}
11	TUNED/Test	OUT	TUNED/Test monitor output
12	STIND	OUT	Stereo indicator
13	SDA	IN/OUT	Serial data input (SDA)
14	SCL	IN	Serial clock input (SCL)
15	VDD selector	IN	V _{DD} selector
16	L GAIN	IN	L-ch. Gain adjustment
17	R GAIN	IN	R-ch. Gain adjustment
18	L OUT	OUT	L-ch. Amp. Output (Z _o = about 200Ω)
19	R OUT	OUT	R-ch. Amp. Output (Z _o = about 200Ω)
20	L DEEMP	OUT	L-ch. De-emphasis (external capacitor 0.015μF = 50μs)
21	R DEEMP	OUT	R-ch. De-emphasis (external capacitor 0.015μF = 50μs)
22	XOSC 1	IN	Crystal oscillator
23	MPX Ref pass	IN/OUT	MPX reference pass
24	XOSC pass	-	Crystal oscillator
25	FM MPX IN	IN	FM MPX input
26	FM/AM DET	OUT	FM/AM detector output
27	ZAP-GND	IN	ZAP-GND
28	ZAP	IN	ZAP (Must be open)
29	AM AF IN	IN	AM AF input
30	FM RDS	OUT	FM detector output (for RDS)
31	PD MPX VCO	IN/OUT	Phase detector for VCO
32	PD ST IND	IN/OUT	Phase detector (for ST ind)
33	PCANDET	IN/OUT	Level detector for MPX pilot cancel
34	SMETER	IN/OUT	FM/AM signal meter
35	FMNUL/VCO	IN/OUT	FM detector/VCO adjustment

■ Pin Descriptions (Continue)

Pin No.	Pin name	タイプ	Description
36	V _{CC}	IN	V _{CC}
37	FM SMADJ	IN/OUT	FM signal meter adjustment
38	GND	IN	GND
39	FMDETPASS1	IN/OUT	FM detector pass 1
40	FMDETPASS2	IN/OUT	FM detector pass 2
41	FM 2IF IN	IN	FM 2nd. IF amp. input
42	FM 2IF REF	IN/OUT	FM 2nd. IF reference
43	AM SM/FMAFC	IN/OUT	AM signal meter/FM-AFC
44	FM Vref	OUT	FM Vref
45	AM-AGC	IN/OUT	AM-AGC level detector
46	FM 1IF OUT	OUT	FM 1st. IF amp. output
47	AM IF IN	IN	AM IF amp. input
48	FM 1IF IN	IN	FM 1st. IF amp. input
49	AM Mix	OUT	AM Mix output
50	RF-V _{CC}	IN	RF-V _{CC}
51	FM MIXOUT1	OUT	FM Mix output 1
52	FM MIXOUT2	OUT	FM Mix output 2
53	FM MIXIN1	IN	FM Mix input 1
54	FM MIXIN2	IN	FM Mix input 2
55	AM RFIN	IN	AM RF input
56	AM RF BIAS	IN/OUT	AM RF bias

■ Absolute Maximum Ratings

Parameter	Symbol	Rating	Unit	Note
Power supply voltage	V_{CC1}	9.0	V	*1
	V_{CC2}	11.1		
Power supply current	I_{CC}	70	mA	
Power dissipation	P_D	439.1	mW	*2
Operating ambient temperature	T_{opr}	-20 to +85	°C	*3
Storage temperature	T_{stg}	-55 to +150	°C	*3

Note *1 : The values under the condition not exceeding the above absolute maximum ratings and the power dissipation.

*2 : The power dissipation shown is the value at $T_a=85\text{ °C}$ for the independent (unmounted) IC package without heat sink.

*3 : Except for the power dissipation, operating ambient temperature, and storage temperature, all ratings are for $T_a=25\text{ °C}$ とする。

■ Operating supply voltage range

Parameter	Symbol	Rating	Unit	Note
Supply voltage range	V_{CC1}	7.2 to 8.5	V	*
	V_{CC2}	7.2 to 11.0		

Note * : The values under the condition not exceeding the above absolute maximum ratings and the power dissipation.

■ Electrical Characteristics $V_{CC1} = 8.0\text{ V}, V_{CC2} = 10\text{ V}$

Note) $T_a = 25^\circ\text{C} \pm 2^\circ\text{C}$ unless otherwise specified.

Parameter	Symbol	Condition	Min.	Typ.	Max.	Unit
AM $f_c = 999\text{ kHz}$						
AM-quiescent current	amIt	No input, Current from V_{CC1}	17	34	51	mA
AM-L-ch. output1	amVoL1	$V_{IN3} = 30\text{ dB}\mu, 1\text{ kHz}, 30\%$ L-ch. output	38	75	150	mV[rms]
AM-R-ch. output1	amVoR1	$V_{IN3} = 30\text{ dB}\mu, 1\text{ kHz}, 30\%$ R-ch. output	38	75	150	mV[rms]
AM-L-ch. output2	amVoL2	$V_{IN3} = 74\text{ dB}\mu, 1\text{ kHz}, 30\%$ L-ch. output	90	160	230	mV[rms]
AM-R-ch. output2	amVoR2	$V_{IN3} = 74\text{ dB}\mu, 1\text{ kHz}, 30\%$ R-ch. output	90	160	230	mV[rms]
AM-S/N ratio1	amSN1	$V_{IN3} = 30\text{ dB}\mu, 1\text{ kHz}, 30\%$ AM-L-ch. output S/N	17	23	—	dB
AM-S/N ratio2	amSN2	$V_{IN3} = 74\text{ dB}\mu, 1\text{ kHz}, 30\%$ AM-L-ch. output S/N	47	53	—	dB
AM-L-ch. THD1	amTL1	$V_{IN3} = 74\text{ dB}\mu, 1\text{ kHz}, 30\%$ L-ch. output distortion factor	—	0.4	1.1	%
AM-R-ch. THD1	amTR1	$V_{IN3} = 74\text{ dB}\mu, 1\text{ kHz}, 30\%$ R-ch. output distortion factor	—	0.4	1.1	%
AM-L-ch. THD2	amTL2	$V_{IN3} = 105\text{ dB}\mu, 1\text{ kHz}, 30\%$ L-ch. output distortion factor	—	0.5	1.3	%
AM-R-ch. THD2	amTR2	$V_{IN3} = 105\text{ dB}\mu, 1\text{ kHz}, 30\%$ R-ch. output distortion factor	—	0.5	1.3	%
AM-SD sensitivity	amSDS	0%mod	32	42	52	$\text{dB}\mu$
FM mono $f_c = 10.7\text{ MHz}$						
FM-RSD output	fmRDS	$V_{IN2} = 80\text{ dB}\mu, 1\text{ kHz}, 100\%$	310	460	610	mV[rms]
FM-quiescent current1	fmIt1	Non input, Current supplied from V_{CC1}	36	55	74	mA
FM-quiescent current2	fmIt2	Non input, Current supplied from V_{CC2}	0.45	0.60	0.75	mA
FM-L-ch. output1	fmVoL1	$V_{IN2} = 80\text{ dB}\mu, 1\text{ kHz}, 100\%$ L-ch. Output	390	610	770	mV[rms]
FM-R-ch. output1	fmVoR1	$V_{IN2} = 80\text{ dB}\mu, 1\text{ kHz}, 100\%$ R-ch. output	390	610	770	mV[rms]
FM-S/N ratio	fmSN	$V_{IN2} = 100\text{ dB}\mu, 1\text{ kHz}, 100\%$ FM-L-ch. output S/N	68	75	—	dB
FM-mono L-ch. THD	fmTmL1	$V_{IN2} = 80\text{ dB}\mu, 1\text{ kHz}, 100\%$ L-ch. output distortion factor	—	0.3	1.3	%
FM-mono R-ch. THD	fmTmR1	$V_{IN2} = 80\text{ dB}\mu, 1\text{ kHz}, 100\%$ R-ch. output distortion factor	—	0.3	1.3	%
FM-SD sensitivity	fmSDS	0%mod	44	57	70	$\text{dB}\mu$
FM-Mute ratio	fmMUTE	$V_{IN2} = 80\text{ dB}\mu, 1\text{ kHz}, 100\%$ L-ch. output ratio to fmVoL.(mute on)	54	60	—	dB

■ Electrical Characteristics $V_{CC1} = 8.0\text{ V}, V_{CC2} = 10\text{ V}$

Note) $T_a = 25^\circ\text{C} \pm 2^\circ\text{C}$ unless otherwise specified.

Parameter	Symbol	Condition	Min.	Typ.	Max.	Unit
FM stereo $f_c = 10.7\text{ MHz}$						
FM-L-ch. separation	fmSepL	$V_{IN2} = 80\text{ dB}\mu, 1\text{ kHz}, 90\%$ L-ch. Output separation	30	40	—	dB
FM-R-ch. separation	fmSepR	$V_{IN2} = 80\text{ dB}\mu, 1\text{ kHz}, 90\%$ R-ch. output separation	30	40	—	dB
FM-stereo L-ch. THD	fmTsL1	$V_{IN2} = 80\text{ dB}\mu, 1\text{ kHz},$ stereo(L+R)90% L-ch. output distortion factor	—	0.35	1.5	%
FM-stereo R-ch. THD	fmTsL1	$V_{IN2} = 80\text{ dB}\mu, 1\text{ kHz},$ stereo(L+R)90% R-ch. output distortion factor	—	0.35	1.5	%
FM-birdy-noise output 1	fmBN1	$f_s = 113\text{ kHz}, 90\%, \text{pilot} =$ 10% L-ch. output level	30	43	—	dB
FM-birdy-noise output 2	fmBN2	$f_s = 189\text{ kHz}, 90\%, \text{pilot} =$ 10% L-ch. output level	34	50	—	dB
FM-carrier leak	fmCL	Pilot = 10% L-ch. output level	35	50	—	dB
FM—stereo detect sensitivity	fmCL	$V_{IN2} = 80\text{ dB}\mu, f_p = 19\text{ kHz}$	1.3	3.0	5.3	%

■ Electrical Characteristics (Reference values for design) $V_{CC1} = 8.0\text{ V}, V_{CC2} = 10\text{ V}$

Note) 1: $T_a = 25^\circ\text{C} \pm 2^\circ\text{C}$ unless otherwise specified.

2: The following values are design reference values. These values do not guarantee the characteristics of the device. Furthermore, they do not guarantee that all devices are tested.

Parameter	Symbol	Condition	Min.	Typ.	Max.	Unit
FM FE $f_c = 98\text{MHz}$						
FM-FE S/N ratio	fmSN	$V_{IN1} = 17\text{ dB}\mu$, Non modulation, 1 kHz, 30%mod FM Det. out2	18	30	—	dB
FM-IF output level	fmIFout	$V_{IN1} = 70\text{ dB}\mu$, FE IF out	39	73	107	mV[rms]
FM-mono $f_c = 10.7\text{MHz}$						
FM-limiting sensitivity	fmVlim	1 kHz, 100% of outpu-3dB (Ref:input level $V_{IN2} = 80\text{dB}\mu$)	—	37	45	dB μ
AM suppression ratio	AMR	$V_{IN2} = 100\text{ dB}\mu$, fm = 1 kHz, AM 30%mod /FM 100%mod	54	72	—	dB
PLL						
Minimum Vt-voltage	Vtmin	Pin 7 output voltage Vt limiter : ON	40	—	—	mV
Charge pump output pull-up current	Icpup	120 μA mode Pin 7 output current	90	120	150	μA
Charge pump output pull-down current	Icpdown	120 μA mode Pin 7 input current	-150	-120	-90	μA
I ² C Interface						
ACK low-level output voltage	V_{ACK}	ACK Pin 11 voltage I = 3 mA	0	—	0.4	V
SCL,SDA input high-level	V_{IHI}	5 V mode	3	—	5.5	V
SCL,SDA input low-level	V_{ILO}	5 V mode	0	—	1.5	V
SCL,SDA input high-level	V_{IHI}	3 V mode	2.1	—	3.5	V
SCL,SDA input low-level	V_{ILO}	3 V mode	0	—	0.9	V