

DATA SHEET

Part No.	AN18401A
Package Code No.	QFN028-P-0405B

Contents

■ Overview	3
■ Features	3
■ Applications	3
■ Package	3
■ Type	3
■ Block Diagram	4
■ Pin Descriptions	5
■ Application Circuit Example	6
■ Absolute Maximum Ratings	7
■ Operating Supply Voltage Range	7

AN18401A

Down Converter IC for GPS

■ Overview

AN18401A, using SiGe process, realizes on-chip LNA with low noise figure and ultra low-power current consumption. As not only the LNA but also VCO is completely built in the IC, it enables further miniaturization of GPS modules and a reduction of components.

■ Features

- A single chip IC for the LNA block with low noise figure (NF = 1.6 dB)
- Low current consumption: 24 mA
- Achievement of saving the space of sets according to significant reduction of external parts (LNA, BPF, VCO, etc)

■ Applications

- For portable terminal, car navigation system

■ Package

- 4-direction 28-pin plastic quad flat non-leaded package (QFN type)

■ Type

- SiGe Bi-CMOS IC

■ Block Diagram

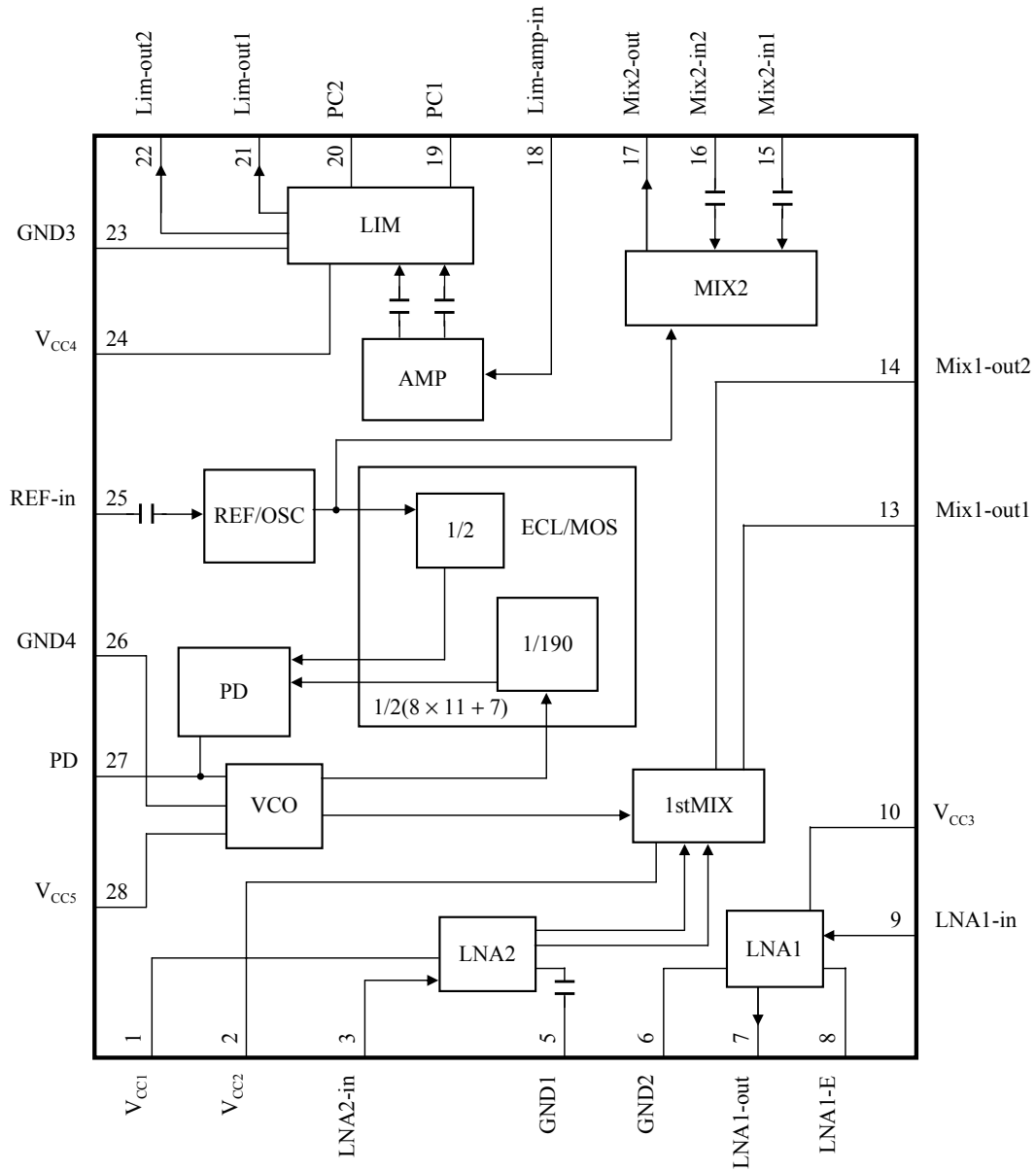

■ Application Circuit Example

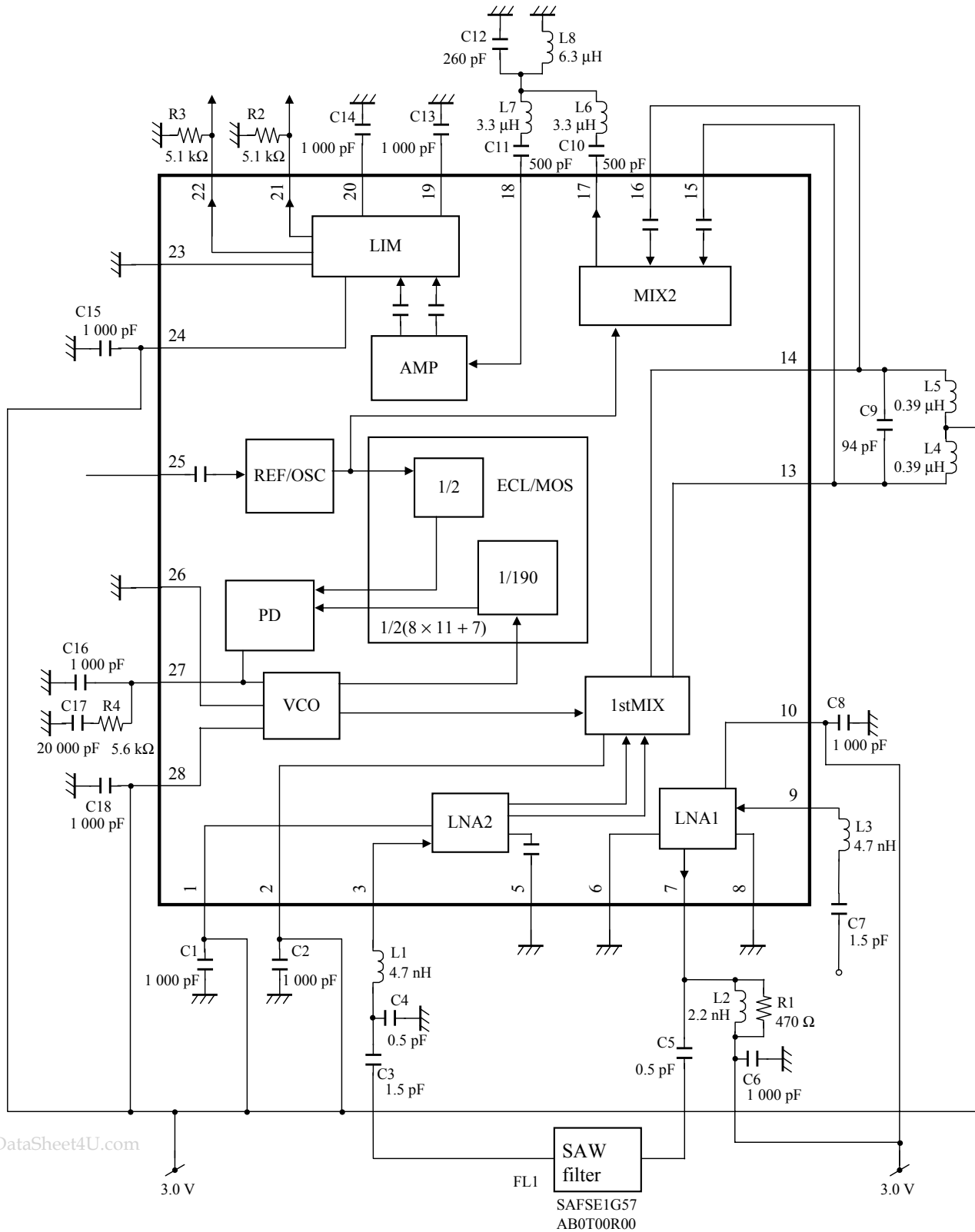

www.DataSheet4U.com

■ Pin Descriptions

Pin No.	Pin name	Type	Description
1	V _{CC1}	Power supply	V _{CC} (LNA2)
2	V _{CC2}	Power supply	V _{CC} (1st Mix)
3	LNA2-in	Input	LNA2 input
4	N.C.	—	No connection
5	GND1	Ground	GND (LNA2)
6	GND2	Ground	GND (LNA1)
7	LNA1-out	Output	LNA1 output
8	LNA1-E	—	LNA1 transistors emitter
9	LNA1-in	Input	LNA1 input
10	V _{CC3}	Power supply	V _{CC} (LNA1)
11	N.C.	—	No connection
12	N.C.	—	No connection
13	Mix1-out1	Output	Mix1 output 1
14	Mix1-out2	Output	Mix1 output 2
15	Mix2-in1	Input	Mix2 input 1
16	Mix2-in2	Input	Mix2 input 2
17	Mix2-out	Output	Mix2 output
18	Lim-amp-in	Input	Lim-amp input
19	PC1	—	Lim-amp bypass capacitor 1
20	PC2	—	Lim-amp bypass capacitor 2
21	Lim-out1	Output	Lim-amp output 1
22	Lim-out2	Output	Lim-amp output 2
23	GND3	Ground	GND (Lim-amp/PLL)
24	V _{CC4}	Power supply	V _{CC} (Lim-amp/PLL)
25	REF-in	Input	REF signal input
26	GND4	Ground	GND (VCO)
27	PD	Output	PD output
28	V _{CC5}	Power supply	V _{CC} (VCO)

■ Absolute Maximum Ratings

A No.	Parameter	Symbol	Rating	Unit	Note
1	Supply voltage	V_{CC}	3.2	V	*1
2	Supply current	I_{CC}	60	mA	—
3	Power dissipation	P_D	182	mW	*2
4	Operating ambient temperature	T_{opr}	-40 to +85	°C	*3
5	Storage temperature	T_{stg}	-55 to +150	°C	*3

Note) *1: The values under the condition not exceeding the above absolute maximum ratings and the power dissipation.

*2: The power dissipation shown is the value at $T_a = 85^\circ\text{C}$ for the independent (unmounted) IC package.

*3: Except for the power dissipation, operating ambient temperature, and storage temperature, all ratings are for $T_a = 25^\circ\text{C}$.

■ Operating Supply Voltage Range

Parameter	Symbol	Range	Unit	Note
Supply voltage range	V_{CC}	2.7 to 3.15	V	*

Note) *: The values under the condition not exceeding the above absolute maximum ratings and the power dissipation.

Request for your special attention and precautions in using the technical information and semiconductors described in this book

- (1) If any of the products or technical information described in this book is to be exported or provided to non-residents, the laws and regulations of the exporting country, especially, those with regard to security export control, must be observed.
- (2) The technical information described in this book is intended only to show the main characteristics and application circuit examples of the products, and no license is granted under any intellectual property right or other right owned by our company or any other company. Therefore, no responsibility is assumed by our company as to the infringement upon any such right owned by any other company which may arise as a result of the use of technical information described in this book.
- (3) The products described in this book are intended to be used for standard applications or general electronic equipment (such as office equipment, communications equipment, measuring instruments and household appliances).
Consult our sales staff in advance for information on the following applications:
 - Special applications (such as for airplanes, aerospace, automobiles, traffic control equipment, combustion equipment, life support systems and safety devices) in which exceptional quality and reliability are required, or if the failure or malfunction of the products may directly jeopardize life or harm the human body.
 - Any applications other than the standard applications intended.
- (4) The products and product specifications described in this book are subject to change without notice for modification and/or improvement. At the final stage of your design, purchasing, or use of the products, therefore, ask for the most up-to-date Product Standards in advance to make sure that the latest specifications satisfy your requirements.
- (5) When designing your equipment, comply with the range of absolute maximum rating and the guaranteed operating conditions (operating power supply voltage and operating environment etc.). Especially, please be careful not to exceed the range of absolute maximum rating on the transient state, such as power-on, power-off and mode-switching. Otherwise, we will not be liable for any defect which may arise later in your equipment.
 - Even when the products are used within the guaranteed values, take into the consideration of incidence of break down and failure mode, possible to occur to semiconductor products. Measures on the systems such as redundant design, arresting the spread of fire or preventing glitch are recommended in order to prevent physical injury, fire, social damages, for example, by using the products.
- (6) Comply with the instructions for use in order to prevent breakdown and characteristics change due to external factors (ESD, EOS, thermal stress and mechanical stress) at the time of handling, mounting or at customer's process. When using products for which damp-proof packing is required, satisfy the conditions, such as shelf life and the elapsed time since first opening the packages.
- (7) This book may be not reprinted or reproduced whether wholly or partially, without the prior written permission of Matsushita Electric Industrial Co., Ltd.