

Contributing to the design of smaller onboard equipment for ETC vehicles.

VCO/PLL+IF Single-Chip IC AN18420A for ETC Vehicle Onboard Equipment

■ Overview

AN18420A is a single-chip IC that incorporates a VCO/PLL block and an IF block to significantly reduce the size and the number of parts used in the wireless block of onboard 5.8GHz electronic toll collection (ETC) systems. This makes a sizable contribution to the design of more compact onboard equipment for ETC vehicles, a product that is expected to grow in popularity.

■ Features

- Substantial space-saver for the wireless block of ETC vehicle onboard equipment. Compactly packaged IC combines with Panasonic MMIC (GN7003S) for the wireless block of ETC vehicle onboard equipment.
- Full incorporation of VCO circuitry including oscillation circuit. Use of SiGe-Bi CMOS process allows full incorporation of 2.9GHz VCO.
- Single-chip configuration includes both VCO/PLL block and IF block.

■ Applications

- ETC vehicle onboard equipment

■ System Block Diagram

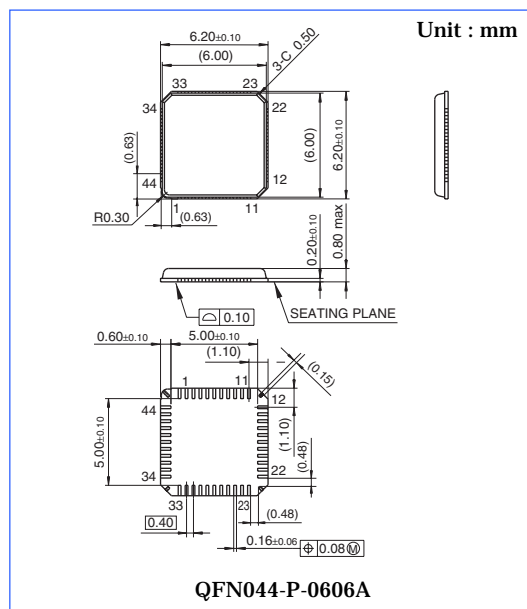
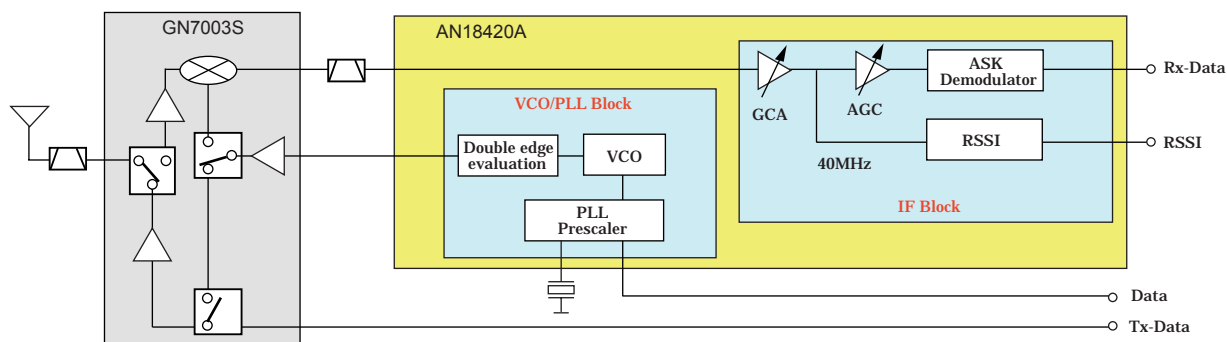

■ Block Diagram

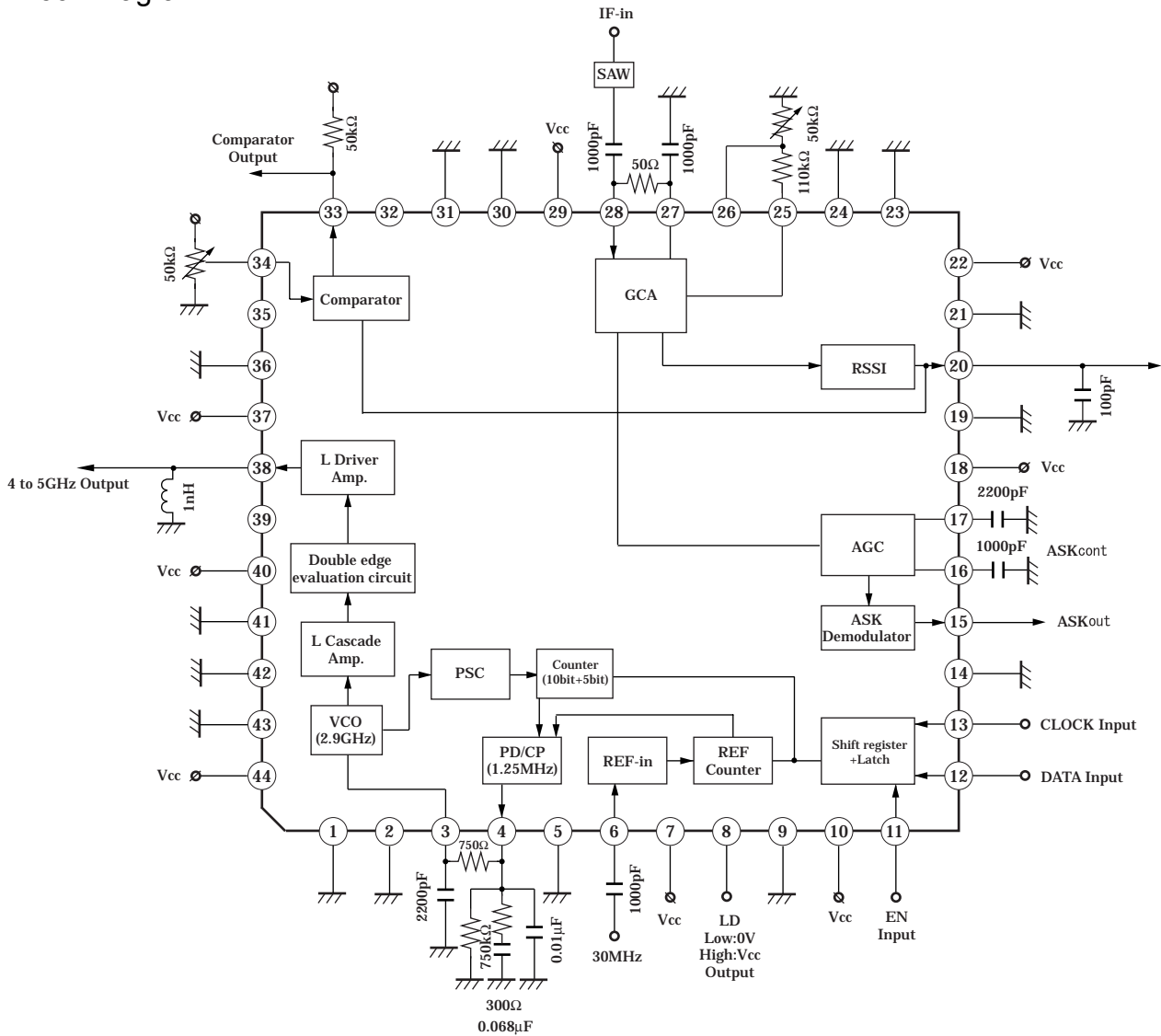

■ Pin Description

PIN		PIN		PIN		PIN	
1	GND	12	DATA	23	GND	34	COMP_REF
2	GND	13	CLOCK	24	GND	35	NC
3	LPF1	14	GND	25	VREF	36	GND
4	LPF2	15	ASKout	26	GCAcont	37	V _{CC}
5	GND	16	ASKcont	27	IF-in1	38	2XOUT
6	REF-in	17	AGC	28	IF-in2	39	NC
7	V _{CC}	18	V _{CC}	29	V _{CC}	40	V _{CC}
8	LD	19	GND	30	GND	41	GND
9	GND	20	RSSIout	31	GND	42	GND
10	V _{CC}	21	GND	32	NC	43	GND
11	EN	22	V _{CC}	33	COMP_OUT	44	V _{CC}

■ Absolute Maximum Ratings

Parameter	Symbol	Rating	Unit	Note
Storage temperature	Tstg	-55 to 150	°C	1
Operating ambient temperature	Topr	-40 to 100	°C	1
Supply voltage	V _{CC}	2.95	V	
Supply current	I _{CC}	95	mA	
Power dissipation	Pd	0.1764	W	2

Note1) Except for the operation ambient temperature and storage temperature, all ratings are for Ta=25 °C.

Note2) Ta=100 °C, Package only.

■ Operating Supply Voltage Range

Operating Supply Voltage Range	V _{CC}	2.6 V to 2.9 V
--------------------------------	-----------------	----------------

■ Electrical Characteristics (unless otherwise specified, ambient temperature is 25°C± 2°C, V_{CC}=2.8V)

Parameter	Symbol	Condition	Min.	Typ.	Max.	Unit
Supply current	I _{CC}	Normal operation /non signal	50	68	87	mA
Variable amp. gain width	Gah	gap of RSSI voltage when variable amplifier gain is high or low	0.1	0.15	0.35	V
Channel select RSSI output1	CHRS1	Vin=-60dBm,40MHz	1.4	1.6	1.8	V
Channel select RSSI output2	CHRS2	Vin=-40dBm,40MHz	1.52	1.72	1.92	V
Channel select RSSI output3	CHRS3	Vin=-17dBm,40MHz	1.8	2.0	2.2	V
ASK Demodulator output low level	VASKL	Vin=-50dBm to -20dBm, 40MHz	—	—	0.4	V
ASK Demodulator output high level	VASKH	Vin=-50dBm to -20dBm, 40MHz	2.7	—	—	V
2nd. Harmonic distortion	TH2C	Vin=-40dBm,40MHz		-15	-11	dB
Double edge evaluation output level	2VCO	fout=5.845GHz、 Load:50Ω	-7	-2.5	+2	dBm
C/N1	CN1	fout=5.845GHz,Δ200kHz	—	—	-82	dBc
C/N2	CN2	fout=5.845GHz,Δ1MHz	—	—	-97	dBc

Reference Data for Designing

Parameter	Symbol	Condition	Min.	Typ.	Max.	Unit
Lock up time	LUT	5815MHz ↔ 5845MHz	—	—	1000	μs
Spurious level 1	SP1	2.9GHz	—	—	-20	dBc
Spurious level 2	SP2	8.7GHz	—	—	-10	dBc
Spurious level 3	SP3	11.6GHz	—	—	-10	dBc
LD voltage L	LDL	An lock	—	—	0.4	V
LD voltage H	LDH	Lock	V _{cc} -0.4	—	—	V
Reference leak	VRFR	1.25MHz offset	—	—	-37	dBc
TCXO input level	REFR	30MHz	-10	0	+10	dBm
Amp. Input resistor	2VCO		—	4	—	kΩ
High level input voltage	CN1	DATA,CLOCK,EN	0.7 × V _{cc}	—	V _{cc}	V
Low level input voltage	CN2	DATA,CLOCK,EN	0	—	0.3 × V _{cc}	V

Package Power Dissipation

