

LINEAR INTEGRATED CIRCUITS DATA

AN253

FM / AM-IF AMPLIFIER and AUDIO AMPLIFIER

The AN253 is a monolithic integrated circuit designed as an FM/AM-IF amplifier and audio amplifier for portable radio sets.

Both FM and AM-IF circuits are designed for coupling with ceramic filters. Since its audio amplifier section includes circuits from a preamplifier to a driver, the device offers a unique feature which allows direct coupling to either an input transformer-coupled circuit or a PNP/NPN complementary circuit. The device is sealed in a reliable ceramic package.

Outline Drawing

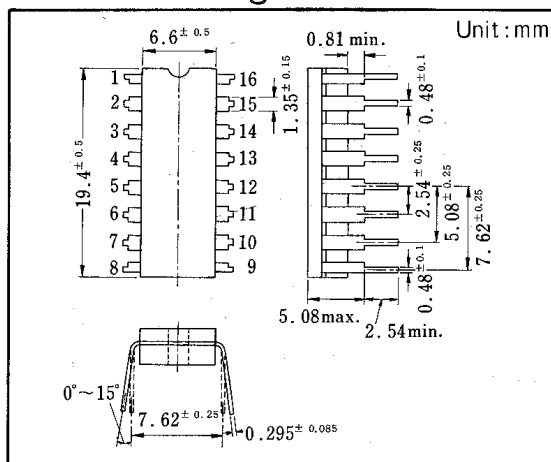

Equivalent Circuit

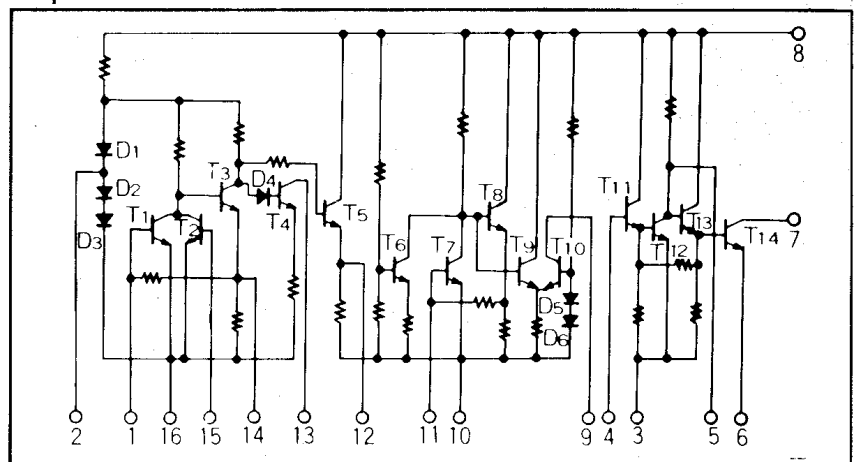

Quick Reference Data

Item	Symbol	Value	Unit	Note
Supply Voltage	Vcc	3~7.5	V	
FM-IF Voltage Gain	Gv(FM)	90	dB	
AM-IF Voltage Gain	Gv(AM)	80	dB	AGC: 60dB
AF Voltage Gain	Gv(AF)	56	dB	

Absolute Maximum Ratings ($T_a=25^\circ\text{C}$)

Item	Symbol	Rating	Unit
Operating Ambient Temperature Range	T_{opr}	$-20 \sim +75$	$^\circ\text{C}$
Storage Temperature Range	T_{stg}	$-60 \sim +150$	$^\circ\text{C}$
Supply Voltage	V_{cc}	7.5	V
Collector Current	I_c	20	mA
Total Current Consumption	I_{tot}	40	mA
Total Power Dissipation	P_T	300	mW

Electrical Characteristics ($V_{cc}=5\text{V}$, $T_a=25^\circ\text{C}$)

Item	Symbol	Conditions	Limits			Unit
			Min.	Typ.	Max.	
Operating Current	$I_{7(T14)}$	Test Circuit 4 ($\frac{V_7}{100\Omega}$)	3.6	5.7	7.7	mA
Operating Current	$I_{9(T10)}$	Test Circuit 1	0.9	2.5	3.75	mA
Bias Reference Voltage	V_{2-16}	Test Circuit 2	1.25	1.5	1.75	V
AM-IF Detection Output Voltage	$V_{O(AM)}$	Test Circuit 4 $f=455\text{KHz}$, $V_{IN}=30\text{dB}$	2.2	3.5	5.6	mV
FM-IF Detection Output Voltage	$V_{O(FM)}$	Test Circuit 4 $f=10.7\text{MHz}$, $V_{IN}=20\text{dB}$	1.8	3	5	mV
Noise Level	V_N	Test Circuit 4 $R_g=5\text{K}\Omega$			1.2	mV
AF Output Voltage	V_{7-3}	Test Circuit 4 $f=1000\text{KHz}$, $V_{IN}=1\text{mV}$	0.35	0.47	0.56	V
Total Current Consumption	I_{tot}	Test Circuit 3	5.4	15	23.5	mA

 $P_T - T_a$ 