

AN3811NK

Cylinder Hall motor driving IC for VCR

■ Overview

The AN3811NK is an IC designed for driving the VCR cylinder Hall motor.

■ Features

- Operating supply voltage range:
 $V_{CC} = 4.5 \text{ V to } 5.5 \text{ V}$
- Motor voltage: $V_M = 5 \text{ V to } 20 \text{ V}$
- Maximum output current: $I_{omax} = 1.5 \text{ A}$
- Three-phase, half-wave and overlap driving lowers a magnetic sound noise.
- PG/FG generating circuit built in
- Thermal protection circuit built in

■ Applications

- VCR

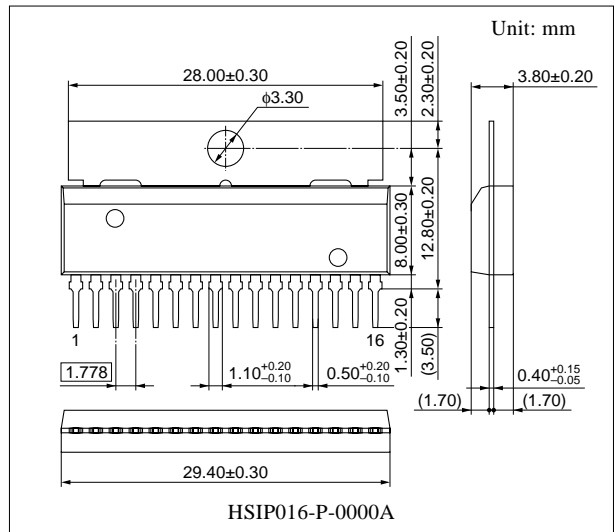

■ Block Diagram

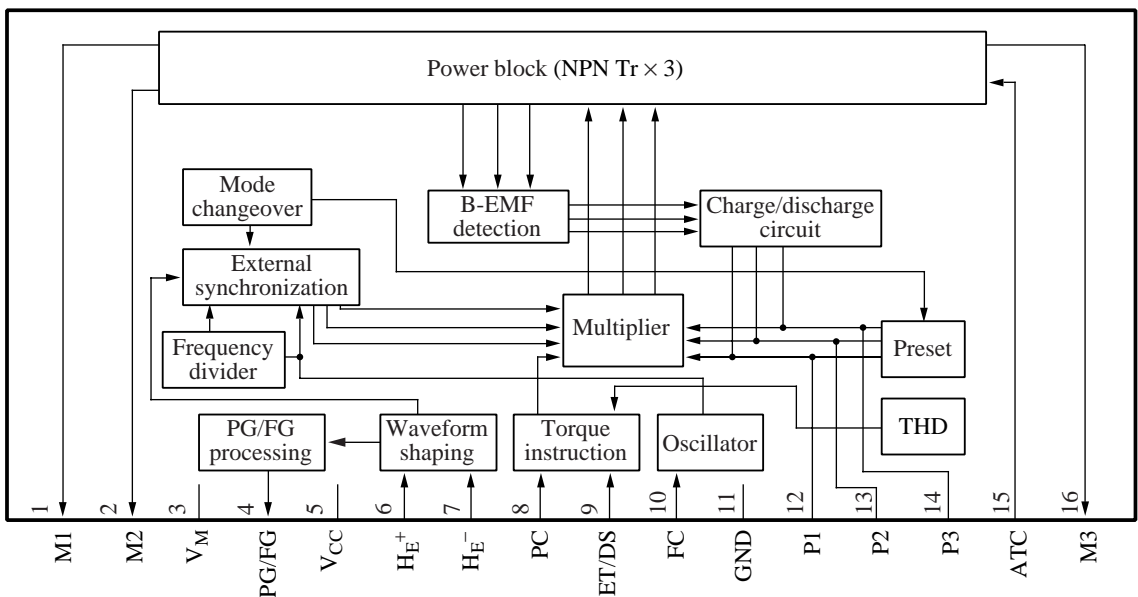

■ Pin Descriptions

Pin No.	Description	Pin No.	Description
1	Driving output 1	9	Torque command input
2	Driving output 2	10	Oscillation output pin
3	Motor power supply pin	11	Grounding pin
4	PG/FG output	12	Position signal pin 1
5	Power supply pin	13	Position signal pin 2
6	Hall element normal phase input	14	Position signal pin 3
7	Hall element reverse phase input	15	Total current output
8	Phase compensation pin	16	Driving output 3

■ Absolute Maximum Ratings

Parameter	Symbol	Rating	Unit
Supply voltage	V_{CC}	6.0	V
Supply current	I_{CC}	—	mA
Power dissipation *2	P_D	1 150	mW
Operating ambient temperature *1	T_{opr}	-20 to +75	°C
Storage temperature *1	T_{stg}	-55 to +150	°C
Circuit voltage *3	V_{n-11}	40	V
Circuit voltage	V_{3-11}	20	V
Circuit current *3	I_n	1.5	A

Note) 1. *1: Except for the power dissipation, operating ambient temperature and storage temperature, all ratings are for $T_a = 25^\circ\text{C}$.

*2: Use this IC within the value of the P_D at $T_a = 75^\circ\text{C}$.

*3: $n = 1, 2, 16$

2. Do not apply external currents or voltages to any pins not specifically mentioned.

3. For circuit currents, '+' denotes currents flowing into the IC, and '-' denotes current flowing out of the IC.

■ Recommended Operating Range

Parameter	Symbol	Range	Unit
Supply voltage	V_{CC}	4.5 to 5.5	V
	V_M	13.5 to 15.5	

■ Electrical Characteristics at $T_a = 25^\circ\text{C}$

Parameter	Symbol	Conditions	Min	Typ	Max	Unit
Circuit current	I_{CC}		5	—	13	mA
Output saturation voltage	$V_{O(SAT)}$	$I_a = 0.6 \text{ A}$	—	—	0.8	V
ATC residual voltage	V_{IDLE}		—	—	4	mA
ATC limiting voltage	V_{LIMIT}	External synchronization	0.31	—	0.44	V
Input/output transfer gain	A_V		0.75	—	1.25	times
Torque command input offset voltage	$E_{T(OFFSET)}$		-50	—	30	mV
ET input current	I_{ET}	ET/DS = 2.5 V	-1.0	—	—	μA
BFG takeout voltage	V_{BFG}		—	—	0.5	V
Hall element input sensitivity	ΔV_{HE}		5	—	22	mV
PG/FG tri-state output voltage 1	$V_{O(H)}$	$I_O = -30 \mu\text{A}$	3.5	—	—	V
PG/FG tri-state output voltage 2	$V_{O(M)}$	$I_O = \pm 10 \mu\text{A}$	2.1	—	2.9	V
PG/FG tri-state output voltage 3	$V_{O(L)}$	$I_O = 30 \mu\text{A}$	—	—	0.9	V
Flyback voltage V-I conversion gain	G_M		13	—	27	μS
Position signal input dynamic range	ΔV_P		0.8	—	—	V
Position signal input offset voltage	$V_{P(OFFSET)}$		-100	—	100	mV
Saturation det. start voltage	$V_{(DET)}$		1.3	—	2.0	V

• Design reference data

Note) The characteristics listed below are theoretical values based on the IC design and are not guaranteed.

Parameter	Symbol	Conditions	Min	Typ	Max	Unit
ATC limiting voltage temperature coefficient	αV_{LIMIT}		—	-900	—	ppm/ $^\circ\text{C}$
FC oscillation frequency	f_C	$C = 0.1 \mu\text{F}$	122	147	184	Hz
FC oscillation frequency coefficient	αf_C	Not considering capacitance variation related to temperature	—	-900	—	ppm/ $^\circ\text{C}$

Note) $V_{CC} = 5 \text{ V}$, $V_M = 14 \text{ V}$ unless otherwise specified.

■ Application Circuit Example

