

AN3840NSR

VTR Capstan-Drive IC

Overview

The AN3840NSR is an IC for driving the VTR capstan motor.

The reduction of acoustic noise, vibration and torque ripple of motor can be realized.

Features

- Output transistor built-in
- Torque ripple cancellation circuit built-in
- Overlap drive
- Output terminal electrolytic capacitor not required
- Thermal protection circuit built-in
- Output maximum current of 1.5 A
- Copper block with good heat radiation built-in

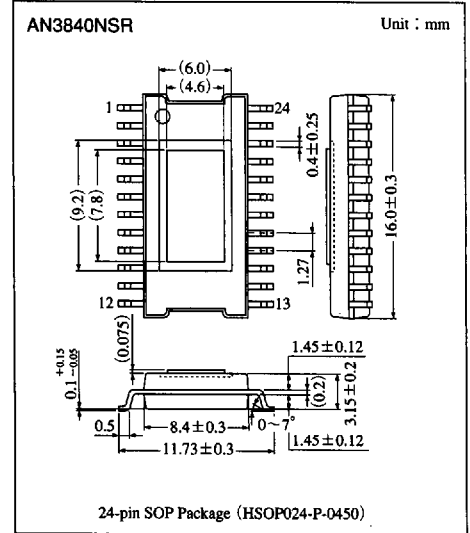

Function Block Diagram

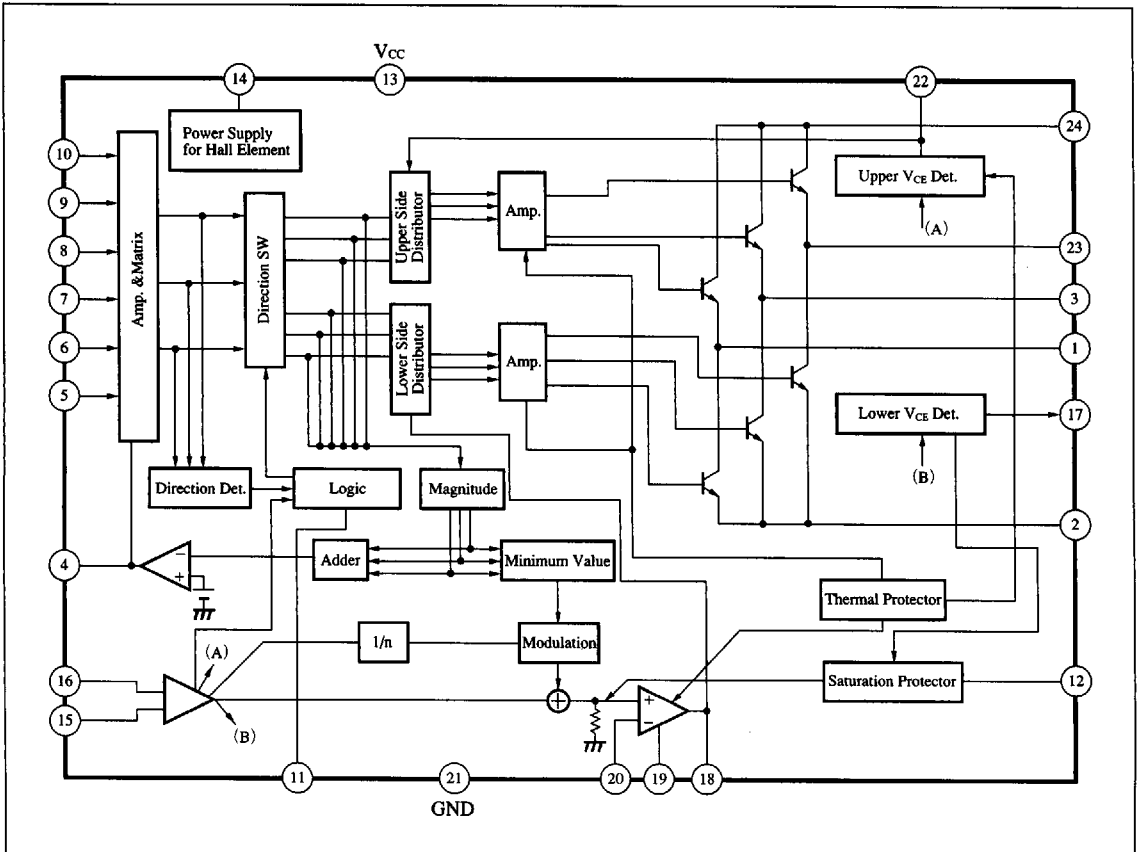

ICs for Motor

■ Absolute Maximum Rating (Ta=25°C)

Parameter	Symbol	Rating	Unit
Supply voltage	V _{CC}	6	V
Motor supply voltage	V ₂	20	V
Motor supply current ^{Note 1)}	I _n	±1.5	A
Output terminal voltage ^{Note 1)}	V _n	20	V
Terminal voltage ^{Note 2)}	V _m	V _{CC}	V
Terminal 14 current	I ₁₄	-100	mA
Power dissipation	P _D	1400	mW
Operating ambient temperature	T _{opr}	-20 to +70	°C
Storage temperature	T _{stg}	-55 to +150	°C

Note 1) Pin No. = 1, 3, 23 Note 2) Pin No. = 5, 6, 7, 8, 9, 10, 11, 15, 16, 19

■ Recommended Operating Range (Ta=25°C)

Parameter	Symbol	Range
Operating supply voltage	V _{CC}	4.5V to 5.5V
Motor supply current	V _M	6V to 18V

■ Electrical Characteristics (Ta=25°C)

Parameter	Symbol	Condition	min	typ	max	Unit
Supply current	I _{CC}	Current of hall element power supply excluded	—	—	15	mA
Torque command reference voltage	ECR		2	—	3.5	V
Torque command voltage	EC		0.5	—	4	V
Torque command input offset voltage	EC _{offset}		-150	—	150	mV
Torque command dead zone	EC _{DZ}		50	—	150	mV
Output idle voltage	ATC _{idle}		—	—	4	mV
Input/Output gain	G _{io}		0.61	0.68	0.75	multiple
Output maximum voltage	ATC _{max}		0.75	—	—	V
Normal rotation command voltage	ED _F		—	—	0.9	V
Stop command voltage	ED _S		1.3	—	3	V
Reverse rotation command voltage	ED _R		3.5	—	—	V
Hall element input offset voltage	H _{offset}		-8	—	8	mV
Lower-side output voltage (1)	V _{N (1)}	ATC=68mV	0.44	—	0.88	V
Lower-side output voltage (2)	V _{N (2)}	ECR=2.5V EC=0.5V	2	—	3.5	V
TL-CS offset voltage	ΔTL	TL=600mV	5	—	40	mV
Ripple cancellation ratio	α	ATC=68mV ATC=47mV	4	—	18	%
Hall element supply voltage	V _{H⁺}	I _{VH⁺} = -20mA	2.6	2.85	3.2	V
Hall element input allowable voltage	H _{in}		1.2	—	3.5	V
Switching supply control output	V _S	EC=ECR, V _M -A1=1.3V	2.1	2.5	2.9	V
Switching supply control output gain	G _{Vs}		-3.4	—	-2.3	multiple

Application Diagram

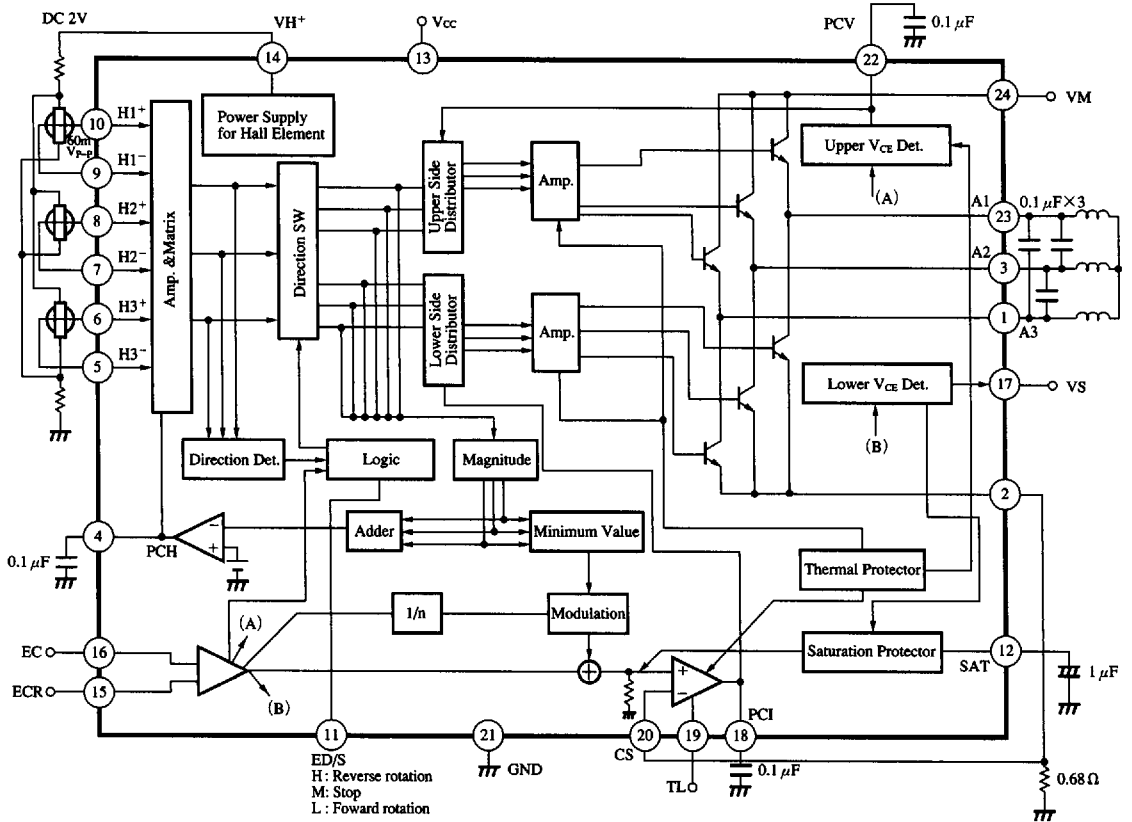



ICs for Motor

Pin Descriptions

Pin No.	Pin name	Standard waveform	Description	Equivalent circuit
1 3 23	A3: Drive output 3 A2: Drive output 2 A1: Drive output 1		Motor coil connected	

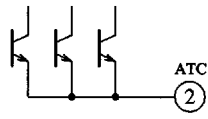
■ Pin Descriptions

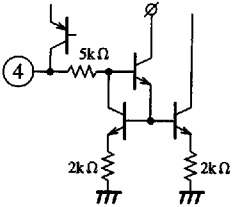
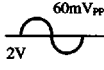
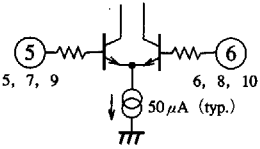
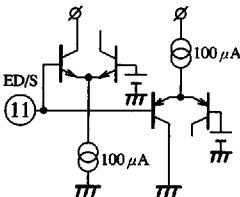
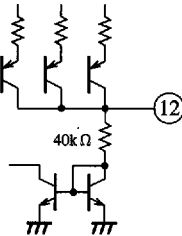
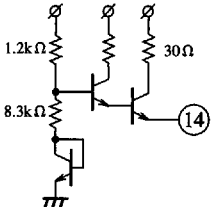
Pin No.	Pin name	Standard waveform	Description	Equivalent circuit
2	ATC : Total current output		The total current of the output transistor is outputted.	
4	PCH : Hall amp. phase compensation		Terminal for phase compensation of AGC loop of Hall amp.	
5 6 7 8 9 10	H ₃ ⁻ : Hall element input H ₃ ⁺ : Hall element input H ₂ ⁻ : Hall element input H ₂ ⁺ : Hall element input H ₁ ⁻ : Hall element input H ₁ ⁺ : Hall element input		Hall Element output of motor is inputted.	
11	ED/S : Direction command input terminal		Terminal for directing the rotation direction and stop of the motor with 3-value input.	
12	SAT : Saturation prevention phase compensation		Terminal for phase compensation of the loop preventing the saturation of output transistor.	
13	V _{cc} : Power supply terminal		The terminal for inputting the supply voltage.	
14	V _H ⁺ : Hall element power supply		The terminal for outputting the supply voltage for Hall element.	

■ Pin Description (cont.)

Pin No.	Pin name	Standard waveform	Description	Equivalent circuit
15	ECR : Torque command reference input terminal		Terminal for inputting the reference voltage of torque command.	
16	EC : Torque command input terminal		Terminal for inputting the torque command voltage.	
17	V _s : Switching power supply control output		Terminal outputting the voltage proportional to V _{CE} of source side output transistor to control the switching power supply.	
18	PCI : Current feedback system phase compensation		Terminal for phase compensation of the system which controls the current of the sink side output transistor.	
19	TL : Torque limit terminal		Terminal setting the maximum voltage of the ATC terminal.	
20	CS : Current detection terminal		Terminal connected to the ATC terminal, for inputting the value which is current-detected by the resistor.	
21	GND :		Ground terminal	
22	PCV : Voltage feedback system phase compensation		Terminal for phase compensation of the system which controls the source side output transistor.	
24	V _M : Motor power supply terminal		Terminal inputting the motor power supply.	

■ Phase of Hall Input and Output Current

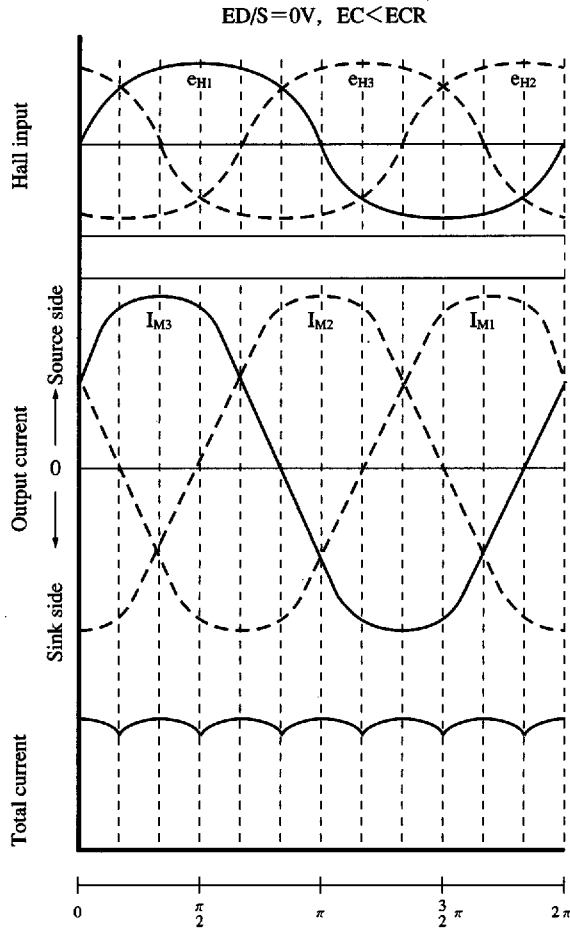

■ Torque Direction Setting Logic

The direction of generated torque is determined according to the following information.

- Information from the rotation direction detection circuit : ER
High : H₁→H₃→H₂
- Brake information from the torque command circuit : EA
High : ECR > EC

- Rotation direction command : ED
High : H₁→H₃→H₂
∴ ED/S = 0V is set for H₁→H₃→H₂ (normal rotation)
- Direction of generated torque : EP
Generated torque rotating in the direction : High : H₁→H₃→H₂
EP is determined by ER, EA and ED as follows :
EP = ED · EA + \overline{ER} · \overline{EA}

	\overline{EA}	EA		\overline{EA}
ED	H	H	H	L
\overline{ED}	H	L	L	L
	ER		ER	

Cannot map of torque direction setting logic