

DATA SHEET

Part No.	AN41224A
Package Code No.	HSOP056-P-0300

Maintenance/Discontinued

Maintenance/Discontinued includes following four Product lifecycle stage.
(planned maintenance type, maintenance type, planned discontinued type, discontinued type)

Contents

- Overview 3
- Features 3
- Applications 3
- Package 3
- Type 3
- Application Circuit Example / Block Diagram 4
- Pin Descriptions 5
- Absolute Maximum Ratings 7
- Operating Supply Voltage Range 7

Maintenance/Discontinued
(planned maintenance type, maintenance type, planned discontinued type, discontinued type)
Maintenance/Discontinued includes following four Product lifecycle stage.

AN41224A

Motor drive IC for Optical Disk

■ Overview

The AN41224A is a single chip IC that uses 1-hall-sensor drive on the input side of the spindle motor drive block and low-noise direct PWM drive of sine wave on the output side, incorporating a PWM 6-channel driver necessary for optical pickup and mechanism driving. It is effective for reducing noise, vibration and power consumption of the optical disk drive.

■ Features

- 1-hall-sensor, 3 phase full-wave and less-noise Direct-PWM driving for Spindle motor driver.
- The actuator (Focus, Tracking, Tilt) drive blocks use linear input and direct PWM drive technique. Moreover, the driver are low in power consumption.
- Sled (Stepping) motor use linear input and direct PWM drive technique. Less external components are used as the current detection resistors are built-in.
- Independent power supply pins are provided for each of the spindle motor, actuator, sled (Stepping) motor, and loading motor drive channels.
- Functions : Motor drive for optical disk /Actuator drive
Spindle motor driver, Actuator (Focus, Tracking, Tilt) driver,
Sled (Stepping) motor driver, Loading motor driver
- Drive voltage : 12V (V_{MSP} , V_{MST}), 5 V (V_{DD} , V_{MAC}), 12V/ 5V (V_{MLO})
- Additional features : Built-in Stand-by function (Spindle and Ch.1 to Ch.6 ALL mute)
1 time / 3 times FG output frequency switch
Short brake / Reverse brake / Auto brake switch
Normal Torque / Low Torque Mode switch
Bias pin for Hall elements
Thermal shutdown
Loading power supply selectable, 12 V / 5 V.
Sled (Stepping) gain switch

■ Applications

- CD-ROM, DVD-ROM, CD-R/RW,
DVD recorder, various combination types.

■ Package

- 56 pin plastic small outline package with heat sink (SOP Type)

■ Type

- Bi-CDMOS IC

Application Circuit Example / Block Diagram (Upward heat radiation)

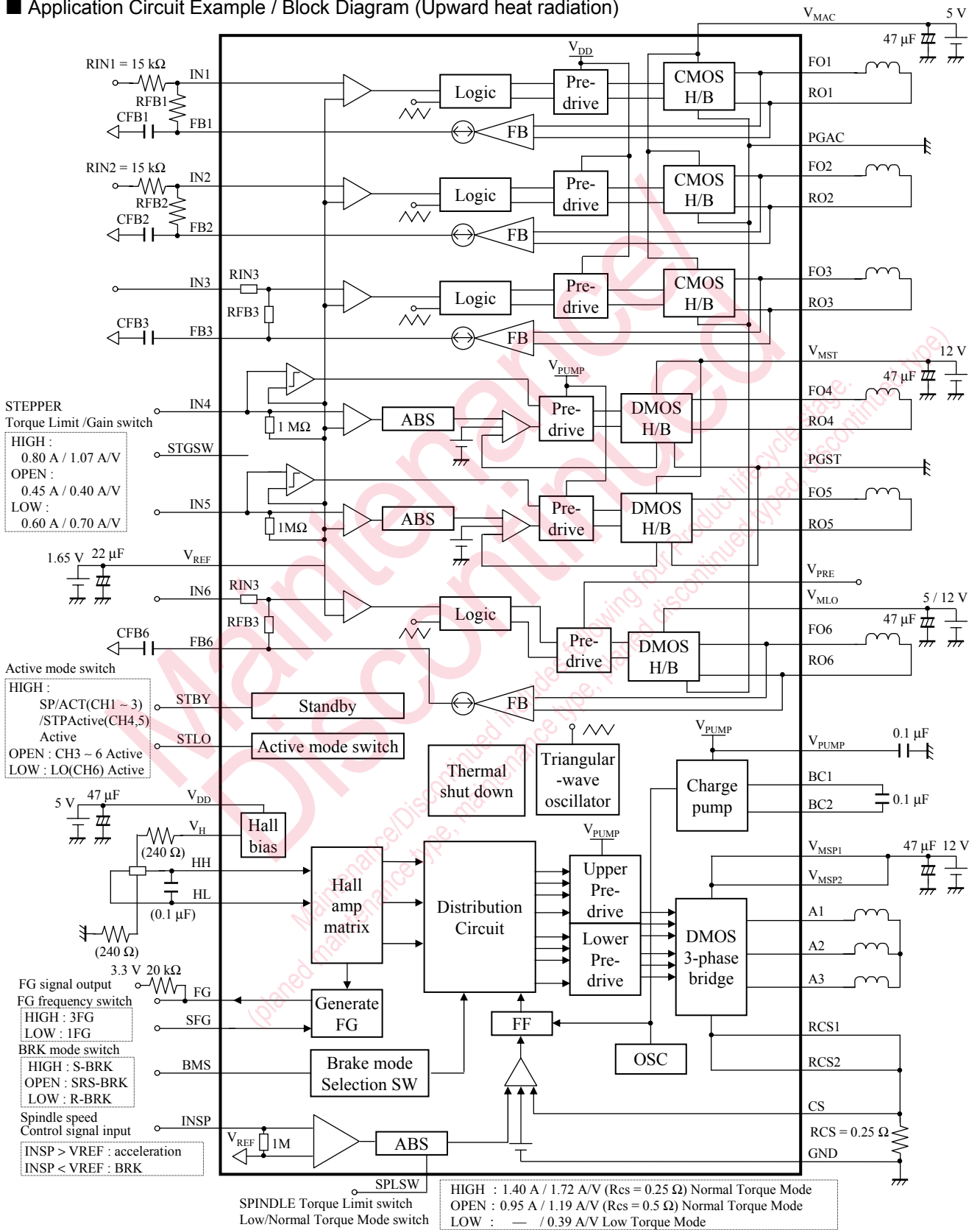

■ Pin Descriptions

Pin No.	Pin name	Type	Description
1	RCS2	Output	Spindle motor drive common source output 2
2	A3	Output	Spindle motor drive output 3
3	A2	Output	Spindle motor drive output 2
4	RCS1	Output	Spindle motor drive common source output 1
5	CS	Input	Spindle motor drive output current detection
6	A1	Output	Spindle motor drive output 1
7	V _{MSP1}	Power supply	Spindle motor drive power supply 1
8	STBY	Input	Total shutdown input
9	STLO	Input	LO shutdown input
10	SFG	Input	Spindle motor drive FG mode switching input
11	FB6	Output	Ch.6 feedback output
12	BMS	Input	Spindle motor drive brake mode switching input
13	STGSW	Input	Ch.4, Ch.5 motor drive input/output Gain switching input
14	SPLSW	Input	Spindle motor torque limit current / Spindle motor drive input/output Gain switching input
15	N.C.	—	N.C.
16	FG	Output	Spindle motor drive FG signal output
17	V _{DD}	Power supply	Control current power supply
18	HH	Input	Spindle motor drive hall element positive input
19	HL	Input	Spindle motor drive hall element negative input
20	V _H	Output	Spindle motor drive hall bias output
21	FO1	Output	Ch.1 non-inverting output
22	RO1	Output	Ch.1 inverting output
23	V _{MAC}	Power supply	Ch.1, Ch.2, Ch.3 coil drive power supply
24	PGAC1	Ground	Ch.1, Ch.2, Ch.3, Ch.6 drive GND1
25	FO2	Output	Ch.2 non-inverting output
26	RO2	Output	Ch.2 inverting output
27	FO3	Output	Ch.3 non-inverting output
28	RO3	Output	Ch.3 inverting output
29	PGAC2	Ground	Ch.1, Ch.2, Ch.3, Ch.6 drive GND2
30	FO6	Output	Ch.6 non-inverting output
31	V _{MLO}	Power supply	Ch.6 motor drive power supply
32	RO6	Output	Ch.6 non-inverting output
33	FB3	Output	Ch.3 feedback output
34	IN3	Input	Ch.3 control signal input
35	IN1	Input	Ch.1 control signal input

■ Pin Descriptions (continued)

Pin No.	Pin name	Type	Description
36	FB1	Output	Ch.1 feedback output
37	V _{PRE}	Input	Ch.6 Pre-Drive power supply
38	FB2	Output	Ch.2 feedback output
39	IN2	Input	Ch.2 control signal input
40	IN6	Input	Ch.6 control signal input
41	INSP	Input	Spindle motor drive control signal input
42	N.C.	—	N.C.
43	V _{REF}	Input	Reference voltage input
44	IN5	Input	Ch.5 control signal input
45	IN4	Input	Ch.4 control signal input
46	GND	Ground	Control current GND
47	V _{PUMP}	Output	Charge pump output
48	BC2	Output	Charge pump setup capacitor 2
49	BC1	Output	Charge pump setup capacitor 1
50	V _{MST}	Power supply	Ch.4, Ch.5 motor drive power supply
51	RO5	Output	Ch.5 inverting output
52	FO5	Output	Ch.5 non-inverting output
53	PGST	Ground	Ch.4, Ch.5 drive GND
54	RO4	Output	Ch.4 inverting output
55	FO4	Output	Ch.4 non-inverting output
56	V _{MSP2}	Power supply	Spindle motor drive power supply 2

■ Absolute Maximum Ratings

A No.	Parameter	Symbol	Rating	Unit	Pin	Notes
1	Supply voltage	V_{DD}, V_{MAC}	6.0	V	—	*1
		$V_{MSP}, V_{MST}, V_{MLO}$	14.0			
2	Supply current	I_{DD}	100	mA	—	—
		I_{MSP}	1 700			
		I_{MAC}	2 500			
		I_{MST}	1 900			
		I_{MLO}	950			
3	Power dissipation	P_D	448	mW	—	*2
4	Operating ambient temperature	T_{opr}	-30 to +85	°C	—	*3
5	Storage temperature	T_{stg}	-55 to +150	°C	—	*3
6	Drive power supply / output instantaneous current spindle	$I_{(p)}$	±3 500	mA	p = 1, 2, 3, 4, 6, 7, 56	*4, *5
7	Drive output current Ch.1, Ch.2	$I_{(q)}$	±1 000	mA	q = 21, 22, 25, 26	*5
8	Drive output current Ch.3	$I_{(r)}$	±500	mA	r = 27, 28	
9	Drive output current Ch.4, Ch.5, Ch.6	$I_{(s)}$	±1 000	mA	s = 30, 32, 51, 52, 54, 55	*5
10	Drive output voltage	$V_{(m)}$	14.7	V	m = 2, 3, 6, 30, 32, 51, 52, 54, 55	*5
11	Drive output voltage	$V_{(l)}$	6.7	V	l = 21, 22, 25, 26, 27, 28	*5
12	Control signal input voltage	$V_{(n)}$	GND to V_{DD}	V	n = 8, 9, 10, 12, 13, 14, 18, 19, 34, 35, 39, 40, 41, 43, 44, 45	*5
13	Hall bias current	$I_{HB(x)}$	30	mA	x = 20	*5

Notes) *1: The values under the condition not exceeding the above absolute maximum ratings and the power dissipation.

The charge pump output circuit voltage will exceed the supply voltage. The limit of the charge pump output circuit voltage is shown in "Operating Supply Voltage / Current Range" on Page8.

*2: The power dissipation shown is the value at $T_a = 85^\circ\text{C}$ for the independent (unmounted) IC package.

When using this IC, refer to the P_D - T_a diagram of the package standard and use under the condition not exceeding the allowable value.

*3: Except for the power dissipation, operating ambient temperature, and storage temperature, all ratings are for $T_a = 25^\circ\text{C}$.

*4: Each output current of ±3 500 mA, ±2 000 mA is only permissible for a period within 1 ms and 50 ms respectively.

*5: Do not apply current or voltage from outside to any pin not listed other than the power supply and ground pins.

For the circuit currents, '+' denotes current flowing into the IC, and '-' denotes current flowing out of the IC.

■ Operating supply voltage range

Parameter	Symbol	Min	Typ	Max	Unit	Notes
Supply voltage range	V_{DD}	4.5	5.0	5.5	V	—
	V_{MAC}	4.5	5.0	5.5		
	V_{MSP}, V_{MST}	10.0	12.0	13.5		*
	$V_{MLO} (5V)$	4.5	5.0	5.5		
	$V_{MLO} (12V)$	10.0	12.0	13.5		

Note) *: The values under the condition not exceeding the above absolute maximum ratings and the power dissipation.

Request for your special attention and precautions in using the technical information and semiconductors described in this book

- (1) If any of the products or technical information described in this book is to be exported or provided to non-residents, the laws and regulations of the exporting country, especially, those with regard to security export control, must be observed.
- (2) The technical information described in this book is intended only to show the main characteristics and application circuit examples of the products, and no license is granted under any intellectual property right or other right owned by our company or any other company. Therefore, no responsibility is assumed by our company as to the infringement upon any such right owned by any other company which may arise as a result of the use of technical information described in this book.
- (3) The products described in this book are intended to be used for standard applications or general electronic equipment (such as office equipment, communications equipment, measuring instruments and household appliances).
Consult our sales staff in advance for information on the following applications:
 - Special applications (such as for airplanes, aerospace, automobiles, traffic control equipment, combustion equipment, life support systems and safety devices) in which exceptional quality and reliability are required, or if the failure or malfunction of the products may directly jeopardize life or harm the human body.
 - Any applications other than the standard applications intended.
- (4) The products and product specifications described in this book are subject to change without notice for modification and/or improvement. At the final stage of your design, purchasing, or use of the products, therefore, ask for the most up-to-date Product Standards in advance to make sure that the latest specifications satisfy your requirements.
- (5) When designing your equipment, comply with the range of absolute maximum rating and the guaranteed operating conditions (operating power supply voltage and operating environment etc.). Especially, please be careful not to exceed the range of absolute maximum rating on the transient state, such as power-on, power-off and mode-switching. Otherwise, we will not be liable for any defect which may arise later in your equipment.
 - Even when the products are used within the guaranteed values, take into the consideration of incidence of break down and failure mode, possible to occur to semiconductor products. Measures on the systems such as redundant design, arresting the spread of fire or preventing glitch are recommended in order to prevent physical injury, fire, social damages, for example, by using the products.
- (6) Comply with the instructions for use in order to prevent breakdown and characteristics change due to external factors (ESD, EOS, thermal stress and mechanical stress) at the time of handling, mounting or at customer's process. When using products for which damp-proof packing is required, satisfy the conditions, such as shelf life and the elapsed time since first opening the packages.
- (7) This book may be not reprinted or reproduced whether wholly or partially, without the prior written permission of Matsushita Electric Industrial Co., Ltd.