

DC IRIS Control LSI for IP Camera and Network Camera

FEATURES

- Built-in DC IRIS controller
- DC IRIS control by 4-line serial data communication
- PCB space saving
- Low power consumption of Iris drive by PWM
- DC Iris servo High-speed response and High stability
- 44 pin Plastic Quad Flat Non-leded Package (QFN Type)

DESCRIPTION

AN41919A is a DC IRIS control LSI for IP camera and security camera. It integrates digital PID control circuit and is able to control various IRIS motors.

APPLICATIONS

- IP camera, security camera

SIMPLIFIED APPLICATION

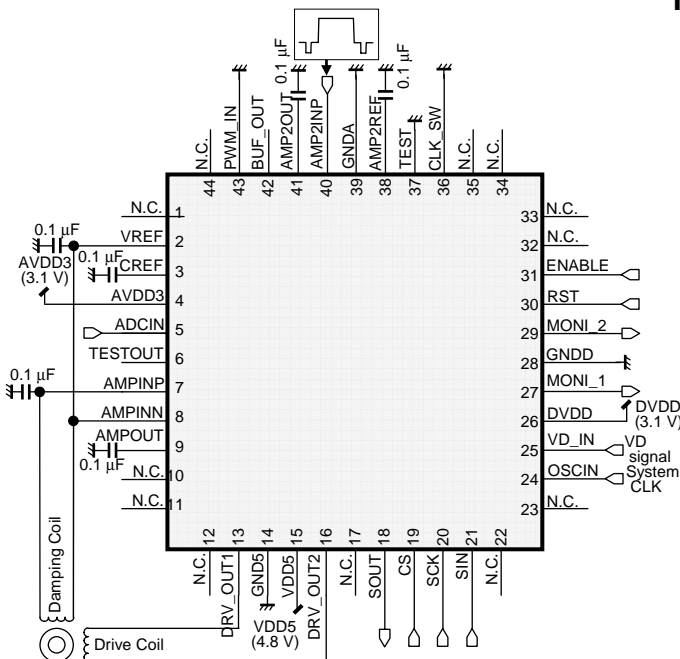

Notes)  
 This application circuit is an example. The operation of mass production set is not guaranteed. You should perform enough evaluation and verification on the design of mass production set. You are fully responsible for the incorporation of the above application circuit and information in the design of your equipment.

DC Iris servo High-speed response and High stability.

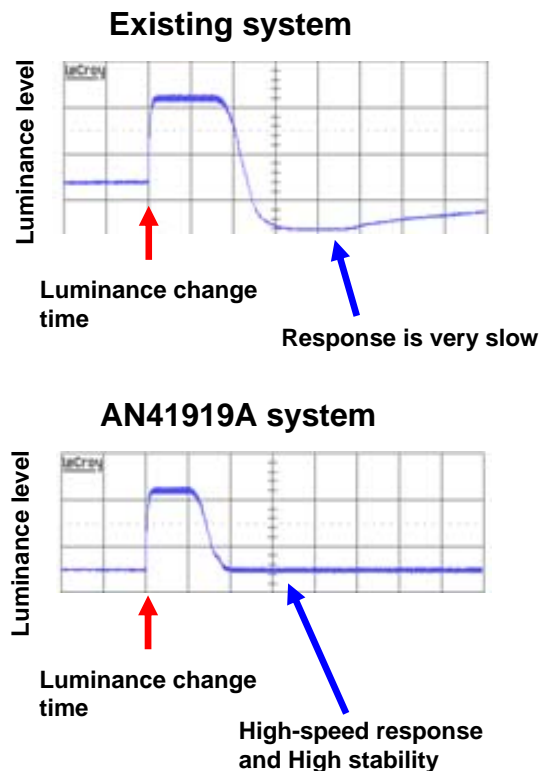

## ABSOLUTE MAXIMUM RATINGS

Parameter	Symbol	Rating	Unit	Note
Controller supply voltage	AVDD3	-0.3 to +4.0	V	*1
	DVDD	-0.3 to +4.0		
Supply voltage for motor controller	VDD5	-0.3 to +6.0	V	*1
Operating ambient temperature	T <sub>opr</sub>	-20 to +85	°C	*2, *4
Operating junction temperature	T <sub>j</sub>	-20 to +125	°C	*2
Storage temperature	T <sub>stg</sub>	-55 to +125	°C	*2
Motor driver H bridge drive current	DRV_OUT1, DRV_OUT2	±0.15	A/ch	—
Input Voltage Range	ADCIN, AMPINP, AMPINN, AMP2INP, CREF, AMP2REF	-0.3 to (AVDD3 + 0.3)	V	*3
	CS, SCK, SIN, OSCIN, VD_IN, RST, ENABLE, CLK_SW, TEST, PWM_IN	-0.3 to (DVDD + 0.3)	V	*3
Output Voltage Range	VREF, TESTOUT, AMP0UT, AMP2OUT	-0.3 to (AVDD3 + 0.3)	V	*3
	SOUT, MONI_1, MONI_2, BUF_OUT	-0.3 to (DVDD + 0.3)	V	*3
ESD	HBM (Human Body Model)	±2	kV	—
	CDM (Charge Device Model)	±1	kV	—

Notes). This product may sustain permanent damage if subjected to conditions higher than the above stated absolute maximum rating. This rating is the maximum rating and device operating at this range is not guaranteeable as it is higher than our stated recommended operating range.

When subjected under the absolute maximum rating for a long time, the reliability of the product may be affected.

\*1: The values under the condition not exceeding the above absolute maximum ratings and the power dissipation.

\*2: Except for the power dissipation, operating ambient temperature, and storage temperature, all ratings are for Ta = 25°C.

\*3: (DVDD + 0.3) V must not be exceeded 4.0 V and (AVDD + 0.3) V must not be exceeded 4.0 V.

\*4: The power dissipation shown is the value at Ta = 85°C for the independent (unmounted) IC package without a heat sink.

When using this IC, refer to the PD-Ta diagram of the package standard and design the heat radiation with sufficient margin so that the allowable value might not be exceeded based on the conditions of power supply voltage, load, and ambient temperature.

**POWER DISSIPATION RATING**

Condition	$\theta_{JA}$	PD (Ta=25 °C)	PD (Ta=70 °C)
Mount on PWB *1	71.8°C/W	1.392W	0.765W
Without PWB	282.9°C/W	0.353W	0.194W

Note). For the actual usage, please refer to the PD-Ta characteristics diagram in the package specification, supply voltage, load and ambient temperature conditions to ensure that there is enough margin follow the power and the thermal design does not exceed the allowable value.

\*1: Glass-Epoxy: 50×50×0.8 (mm) , heat dissipation fin: Dai-pad , the state where it does not mount.



**CAUTION**

Although this has limited built-in ESD protection circuit, but permanent damage may occur on it. Therefore, proper ESD precautions are recommended to avoid electrostatic damage to the MOS gates

**RECOMMENDED OPERATING CONDITIONS**

Parameter	Symbol	Min.	Typ.	Max.	Unit	Note
Supply voltage range	AVDD3, DVDD	2.7	3.1	3.6	V	*1
	VDD5	3.0	4.8	5.5	V	*1
Input Voltage Range	ADCIN, AMPINP, AMPINN, AMP2INP, CREF, AMP2REF	-0.3	—	AVDD3 + 0.3	V	*2
	CS, SCK, SIN, OSCIN, VD_IN, RST, ENABLE, CLK_SW, TEST, PWM_IN	-0.3	—	DVDD + 0.3	V	*2
Output Voltage Range	VREF, TESTOUT, AMPOUT, AMP2OUT	-0.3	—	AVDD3 + 0.3	V	*2
	SOUT, MONI_1, MONI_2, BUF_OUT	-0.3	—	DVDD + 0.3	V	*2
Output Current Range	DRV_OUT1, DRV_OUT2	-0.15	—	0.15	A	*1
External Constants	C <sub>VREF</sub>		0.1		μF	
	C <sub>CREF</sub>		0.1		μF	
	C <sub>AMPINP</sub>		0.1		μF	
	C <sub>AMPOUT</sub>		0.1		μF	
	C <sub>AMP2REF</sub>		0.1		μF	
	C <sub>AMP2OUT</sub>		0.1		μF	
Operating ambient temperature	Ta <sup>opr</sup>	-20		85	°C	

Note) \*1 : The values under the condition not exceeding the above absolute maximum ratings and the power dissipation.

\*2 : (DVDD + 0.3 ) V must not be exceeded 4.0 V and (AVDD + 0.3 ) V must not be exceeded 4.0 V.

**ELECTRICAL CHARACTERISTICS**

VDD5 = 4.8 V, DVDD = AVDD3 = 3.1 V.  $T_a = 25^{\circ}\text{C} \pm 2^{\circ}\text{C}$

Parameter	Symbol	Condition	Limits			Unit	Note
			Min	Typ	Max		
<b>Current circuit</b>							
3 V supply current on Reset	$I_{cc3_{reset}}$	RST = Low, No 27 MHz input	—	0	10.0	$\mu\text{A}$	—
3 V supply current on Enable	$I_{cc3_{enable}}$	RST = High, ENABLE = High, 27 MHz input, Output open	—	7	14	mA	—
VDD5 supply current on Reset	$I_{cc5_{reset}}$	RST = Low, No 27 MHz input	—	0	3.0	$\mu\text{A}$	—
VDD5 supply current on Enable	$I_{cc5_{enable}}$	RST = High, ENABLE = High, 27 MHz input, Output open	—	0.2	0.4	mA	—
Supply current on Standby	$I_{cC_{standby}}$	RST = High, ENABLE = Low, 27 MHz input, output open Total current	—	2	4	mA	—
<b>Digital input / output</b>							
High-level input	$V_{in(H)}$	RST	$0.54 \times$ DVDD	—	DVDD + 0.3	V	—
Low-level input	$V_{in(L)}$	RST	-0.3	—	$0.2 \times$ DVDD	V	—
SOUT High-level output	$V_{out(H)} :$ SDATA	[SOUT] 1 mA Source	DVDD - 0.5	—	—	V	—
SOUT Low-level output	$V_{out(L)} :$ SDATA	[SOUT] 1 mA Sink	—	—	0.5	V	—
MONI_1 to 2 High-level output	$V_{out(H)} :$ MUX	—	$0.9 \times$ DVDD	—	—	V	—
MONI_1 to 2 Low-level output	$V_{out(L)} : \text{MUX}$	—	—	—	$0.1 \times$ DVDD	V	—
Input pull-down resistance	$R_{pullret}$	RST, ENABLE	50	100	200	$k\Omega$	—
<b>Motor driver</b>							
H bridge ON resistance	$R_{onIR}$	IM = 50 mA	—	—	5	$\Omega$	—
H bridge leak current	$I_{leakIR}$	—	—	—	0.8	$\mu\text{A}$	—

**ELECTRICAL CHARACTERISTICS (Continued)**VM=24V, T<sub>a</sub> = 25°C±2°C unless otherwise noted.

Parameter	Symbol	Condition	Limits			Unit	Note
			Min	Typ	Max		
<b>AMP (Damping Coil signal Amplifier)</b>							
Input voltage range	V <sub>IN</sub>	AMPINN = 1.55 V	1.05	—	2.05	V	—
Input offset voltage	V <sub>OF</sub>	—	-15	—	15	mV	—
Output voltage (Low)	V <sub>OL</sub>	ILOAD = -100 μA	—	0.2	0.4	V	—
Output voltage (High)	V <sub>OH</sub>	ILOAD = 100 μA	AVDD3 - 0.4	AVDD3 - 0.2	—	V	—
Gain	V <sub>OG</sub>	Gain setting value : 0h	19.7	21.9	24.1	V/V	—
<b>AMP2 (CDS signal Amplifier)</b>							
Input offset voltage	V <sub>OF2</sub>	—	-20	—	20	mV	—
Output voltage (Low)	V <sub>OL2</sub>	ILOAD = -100 μA	—	0.2	0.4	V	—
Output voltage (High)	V <sub>OH2</sub>	ILOAD = 100 μA	AVDD3 - 0.4	AVDD3 - 0.2	—	V	—
Gain	V <sub>OG2</sub>	Gain setting value : 9h	1.75	2	2.25	V/V	—
<b>Reference Voltage Block</b>							
Output voltage	VREF	ILOAD = 0 A, CVREF = 0.1 μF	1.45	1.55	1.65	V	—

**ELECTRICAL CHARACTERISTICS (continued)**

VDD5 = 4.8 V, DVDD = AVDD3 = 3.1 V    T<sub>a</sub> = 25°C±2°C

Parameter	Symbol	Condition	Limits			Unit	Note
			Min	Typ	Max		
<b>Serial port input</b>							
Serial clock	Sclock	—	1	—	5	MHz	*1
SCK low time	T1	—	100	—	—	ns	*1
SCK high time	T2	—	100	—	—	ns	*1
CS setup time	T3	—	60	—	—	ns	*1
CS hold time	T4	—	60	—	—	ns	*1
CS disable high time	T5	—	100	—	—	ns	*1
SIN setup time	T6	—	50	—	—	ns	*1
SIN hold time	T7	—	50	—	—	ns	*1
SOUT delay time	T8	—	—	—	60	ns	*1
SOUT hold time	T9	—	60	—	—	ns	*1
SOUT Enable-Hi-Z time	T10	—	—	—	60	ns	*1
SOUT Hi-Z-Enable time	T11	—	—	—	60	ns	*1
SOUT C load	T <sub>sc</sub>	—	—	—	40	pF	*1
<b>Digital input / output</b>							
High-level input threshold voltage	V <sub>in(H)</sub>	SCK, SIN, CS, OSCIN, VD_IN, ENABLE, CLK_SW TEST	—	1.36	—	V	*1
Low-level input threshold voltage	V <sub>in(L)</sub>	SCK, SIN, CS, OSCIN, VD_IN, ENABLE, CLK_SW TEST	—	1.02	—	V	*1
RST signal pulse width	T <sub>rst</sub>	—	100	—	—	μs	*1
Input hysteresis width	V <sub>hysin</sub>	SCK, SIN, CS, OSCIN, VD_IN, ENABLE, CLK_SW TEST	—	0.34	—	V	*1
CS signal wait time 1	T <sub>(VD-CS)</sub>	—	400	—	—	ns	*1
CS signal wait time 2	T <sub>(CS-DT1)</sub>	—	5	—	—	μs	*1

Note) \*1 : Typical Value checked by design.

**ELECTRICAL CHARACTERISTICS** (Continued)

VDD5 = 4.8 V, DVDD = AVDD3 = 3.1 V  $T_a = 25^{\circ}\text{C} \pm 2^{\circ}\text{C}$

Parameter	Symbol	Condition	Limits			Unit	Note
			Min	Typ	Max		
<b>IRIS control</b>							
AD sampling frequency	$\text{IRIS}_{\text{Sample}}$	OSCIN = 27 MHz	—	500	—	kHz	*1
<b>Thermal shutdown</b>							
Thermal shutdown operation temperature	$T_{\text{tsd}}$	—	—	150	—	$^{\circ}\text{C}$	*1
Thermal shutdown hysteresis width	$\Delta T_{\text{tsd}}$	—	—	40	—	$^{\circ}\text{C}$	*1
<b>Supply voltage monitor circuit</b>							
AVDD3 Reset operation	$V_{\text{rston}}$	—	—	2.27	—	V	*1
AVDD3 Reset hysteresis width	$V_{\text{rsthys}}$	—	—	0.2	—	V	*1
VDD5 Reset operation	$V_{\text{rstlSon}}$	—	—	2.2	—	V	*1
VDD5 Reset hysteresis width	$V_{\text{rstlShys}}$	—	—	0.2	—	V	*1
<b>8 bit DAC for Damping Coil signal Amplifier Offset adjustment</b>							
Adjustment range (High)	DAOTHof	—	—	AVDD3	—	V	*1
Adjustment range (Low)	DAOTLof	—	—	0	—	V	*1
<b>10 bit ADC</b>							
Input Range (High)	$V_{\text{in(H)}}$	—	—	—	AVDD3 - 0.2	V	*1
Input Range (Low)	$V_{\text{in(L)}}$	—	0.2	—	—	V	*1
DNLE (Differential linearity error)	DNL10A	—	—	1.0	—	LSB	*1
INLE (Integral linearity error)	INL10A	—	—	2.0	—	LSB	*1
<b>Reference voltage output block</b>							
Output voltage 1	VREFH	ILOAD = 100 mA, CVREF = 0.1 mF	—	—	VREF + 0.1	V	*1
Output voltage 2	VREFL	ILOAD = -100 mA, CVREF = 0.1 mF	VREF - 0.1	—	—	V	*1

Note) \*1 : Typical Value checked by design.

PIN CONFIGURATION

Top View

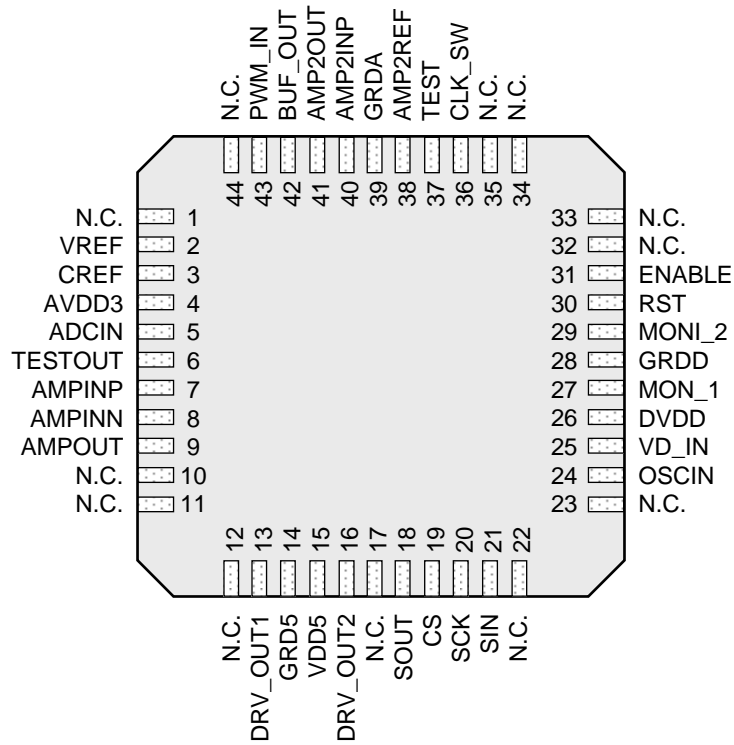



**PIN FUNCTIONS**

Pin No.	Pin name	Type	Description
1, 10, 11, 12, 17, 22, 23, 32, 33, 34, 35, 44	N.C.	—	N.C.
2	VREF	Output	Reference voltage for damping coil signal amplifier
3	CREF	—	(AVDD3)/2 capacitor connection pin
4	AVDD3	Power supply	3 V analog power supply
5	ADCIN	Input	ADC test input
6	TESTOUT	Output	Test output
7	AMPINP	Input	Damping coil signal amplifier non-inverting input
8	AMPINN	Input	Damping coil signal amplifier inverting input
9	AMPOUT	Output	Damping coil signal amplifier output
13	DRV_OUT1	Output	Motor output 1
14	GND5	Ground	GND for motor
15	VDD5	Power supply	Power supply for motor
16	DRV_OUT2	Output	Motor output 2
18	SOUT	Output	Serial data output
19	CS	Input	Chip select signal input
20	SCK	Input	Serial clock input
21	SIN	Input	Serial data input
24	OSCIN	Input	System clock input
25	VD_IN	Input	IRIS video sync signal input
26	DVDD	Power supply	3 V digital power supply
27	MONI_1	Output	Monitor output 1
28	GNDD	Ground	Digital GND
29	MONI_2	Output	Monitor output 2
30	RST	Input	Reset signal input
31	ENABLE	Input	Enable signal input
36	CLK_SW	Input	System clock frequency select
37	TEST	Input	Test mode input
38	AMP2REF	—	Reference voltage for CDS signal amplifier
39	GNDA	Ground	3 V analog GND
40	AMP2INP	Input	CDS signal input
41	AMP2OUT	Output	CDS signal amplifier output
42	BUF_OUT	Output	PWM signal output
43	PWM_IN	Input	PWM signal input

Notes) Concerning detail about pin description, please refer to OPERATION and APPLICATION INFORMATION section.

FUNCTIONAL BLOCK DIAGRAM

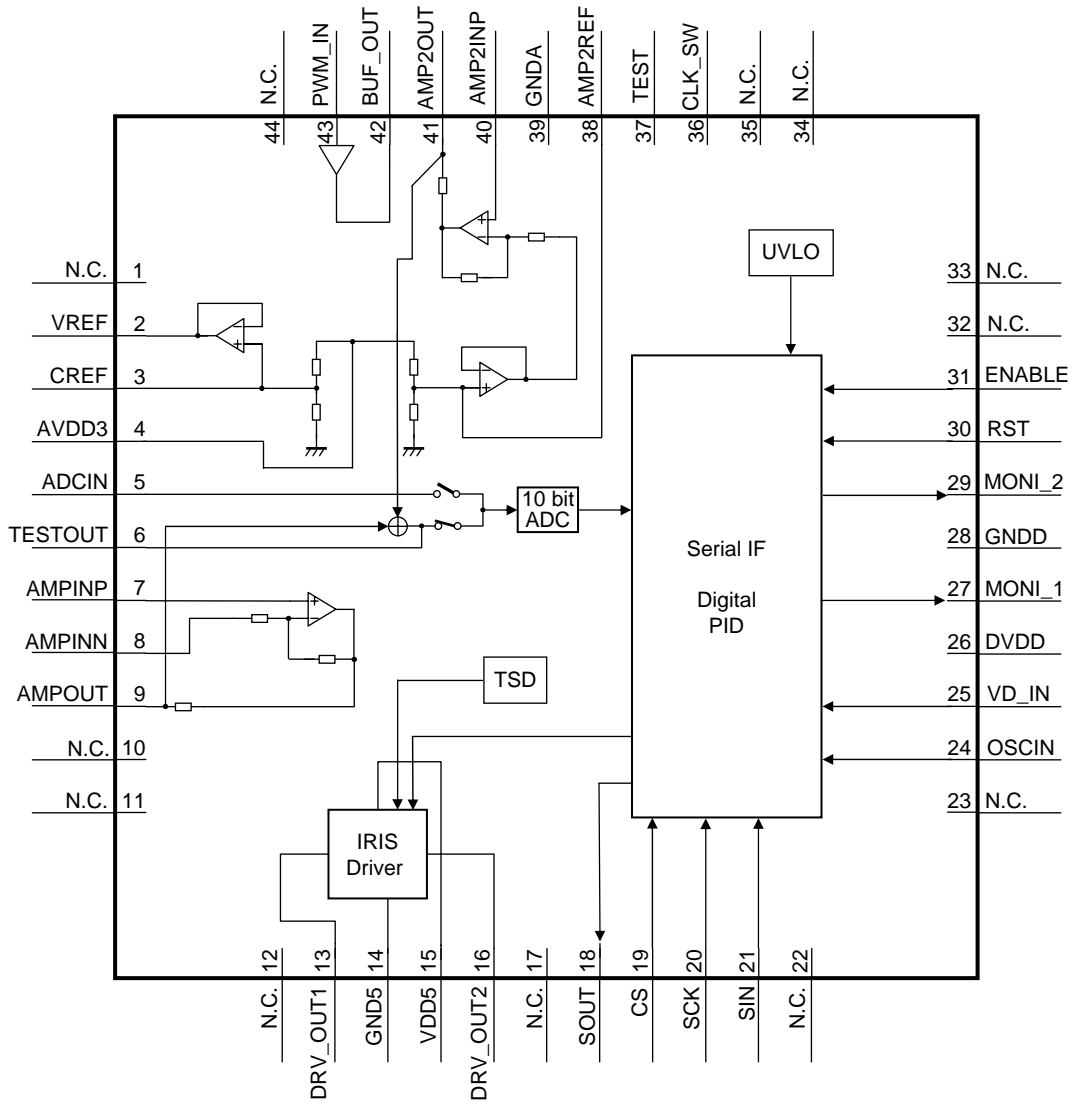

Note) This block diagram is for explaining functions. Part of the block diagram may be omitted, or it may be simplified.

OPERATION

1. Control mode

- 1) Read / Write of serial data

Note)The characteristics listed below are reference values derived from the design of the LSI and are not guaranteed.

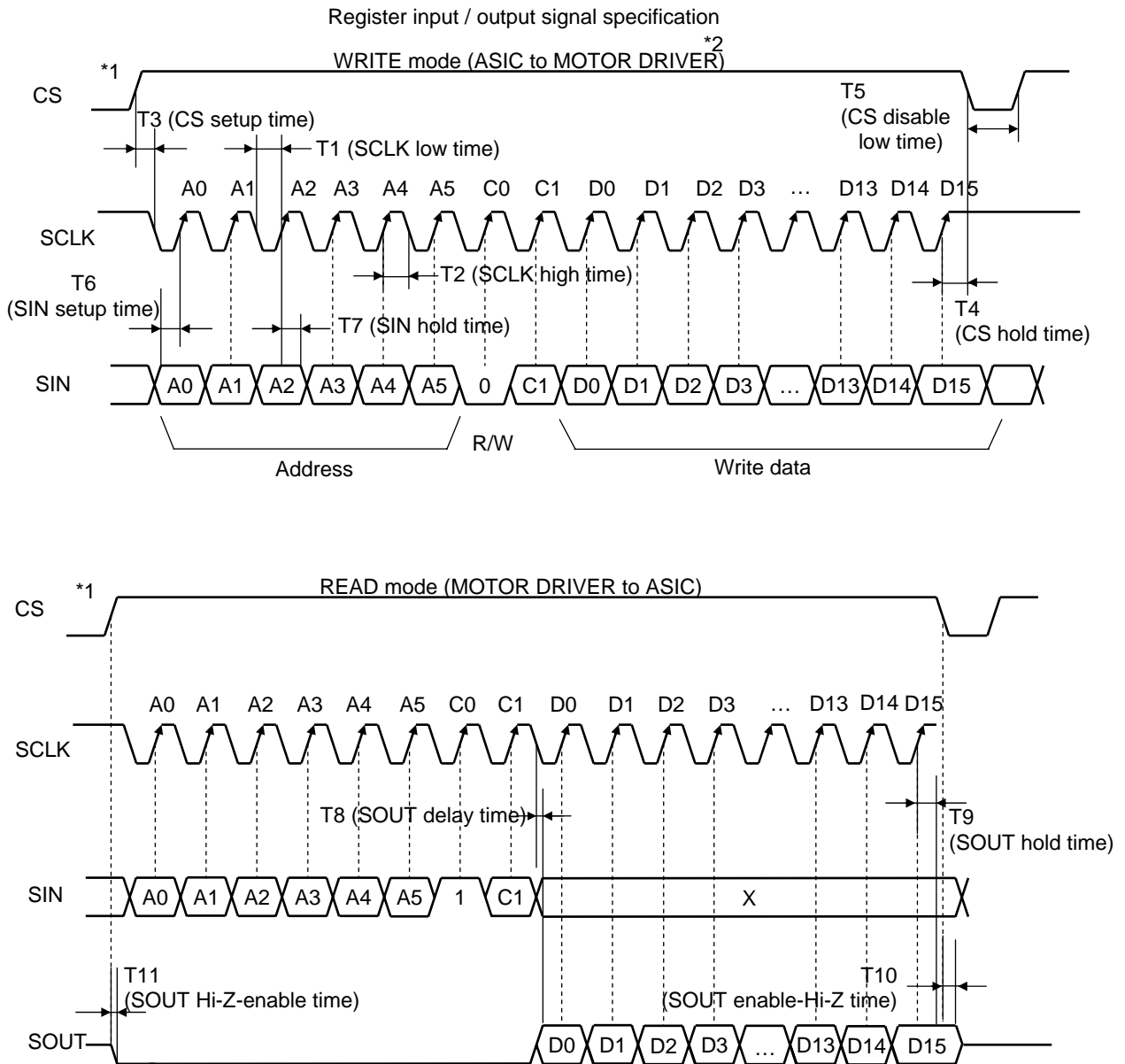

Notes) \*1 :CS default value of each cycle (Write / Read mode) starts from Low-level.

\*2 :It is necessary to input the system clock OSCIN in write mode.

OPERATION(continued)

1. Control mode(continued)

2) Register table

Register table

Address	Register name	Bit															
		15	14	13	12	11	10	9	8	7	6	5	4	3	2	1	0
00h	Luminance Target	—	—	—	—	—	—	Y_TGT[9:0]									
01h	Target Update Timing	Y_P WM_ POL	Y_P WM_ ON	CDS_ AMP_ OFF	Reser ved	—	—	—	—	TGT_UPDATE[7:0]							
02h	PID Filter(1)	—	—	—	TGT_ FLT_ OFF	TGT_LPF_FC[3:0]			—	—	DEC_ AVE	AVE_SPEED[4:0]					
03h	PID(1)	PID_ INV	—	—	LMT_ ENB	ARW[3:0]			—	DGAIN[6:0]							
04h	PID(2)	PID_POLE[3:0]			PID_ZERO[3:0]			IRIS_ROUND[3:0]			IRIS_CALC_NR[3:0]						
05h	PID Filter(2)	—	—	—	—	PWM _ FIL_ OFF	PWM_LPF_FC[2:0]		AS_F LT_O FF	ASOUND_LPF_FC[2:0]		OVER_LPF_ FC_ 2ND[1:0]	OVER_LP F_FC_ 1ST[1:0]				
06h	Offset DAC	—	—	—	—	—	—	—	DAMP_OFFSET_DAC[7:0]								
07h	Analog Adder	—	—	—	—	Y_MIX[3:0]			—	—	—	—	DAMP_MIX[3:0]				
08h	Analog LPF/Gain	Y_GAIN[3:0]			DAMP_GAIN[3:0]			—	—	Y_FLT[1:0]		—	—	DAMP_FLT[1:0]			
09h	PWM/Enable	TEST EN1	—	DT_ADJ_ IRIS[1:0]	—	PWM_IRIS[2:0]		PID_CLIP[3:0]			ASWMODE[1:0]	VD_ POL	EN AB LE				
0Ah	ADC Read	—	—	—	—	—	—	IRSAD[9:0] read only									
0Bh	Reserved	Panasonic Reserved															
0Ch	Pulse Generator	—	—	—	—	—	—	START1[9:0]									
0Dh	Pulse Generator	P1EN	—	—	—	WIDTH1[11:0]											
0Eh	Pulse Generator	—	—	—	—	—	—	START2[9:0]									
0Fh	Pulse Generator	P2EN	—	—	—	—	—	—	—	—	WIDTH2[5:0]						
20h	Test mode selection	TEST EN2	—	—	—	—	—	Panasonic Reserved		—	—	—	—	PLS_SEL[3:0]*			
21h	Test mode selection	—	—	—	—	—	DUTY_ TES T	TGT_IN_TEST[9:0]									
22h	Reserved	Panasonic Reserved															
3Fh	Reserved	Panasonic Reserved															

— : Usprohibited

**OPERATION(continued)**

**1. Control mode(continued)**

3) Register function table

Address	Register name / Bit wide	Function
00h	Y_TGT[9:0]	Luminance target
01h	TGT_UPDATE[7:0]	Y_TGT update delay time
	CDS_AMP_OFF	Luminance signal amplifier enable / disable
	Y_PWM_ON	PWM (luminance signal modulation) buffer enable / disable
	Y_PWM_POL	PWM_IN polarity selection
02h	AVE_SPEED[3:0]	DEC_AVE time controller
	DEC_AVE	Moving average of Luminance target
	TGT_LPF_FC[3:0]	Luminance target value LPF cut-off frequency
	TGT_FLT_OFF	IRIS target value LPF function enable / disable
03h	DGAIN[6:0]	PID controller digital gain
	ARW[3:0]	Number of bits in PID controller integrator
	LMT_ENB	PID controller integral stop
	PID_INV	PID controller polarity
04h	IRIS_CALC_NR[3:0]	PID controller integral error cumulative prevention level
	IRIS_ROUND[3:0]	PID controller differential error cumulative prevention level
	PID_ZERO[3:0]	PID controller zero point
	PID_POLE[3:0]	PID controller pole
05h	OVER_LPF_FC_1ST[1:0]	ADC feedback filter (1) cut-off frequency
	OVER_LPF_FC_2ND[1:0]	ADC feedback filter (2) cut-off frequency
	ASOUND_LPF_FC[2:0]	Filter cut-off frequency before PID controller
	AS_FLT_OFF	Filter before PID controller enable / disable
	PWM_LPF_FC[2:0]	LPF cut-off frequency after PID controller
	PWM_FLT_OFF	LPF after PID controller enable / disable
06h	DAMP_OFFSET_DAC[7:0]	Offset adjustment for damping coil output amplifier
07h	DAMP_MIX[3:0]	Damping coil signal mixed gain
	Y_MIX[3:0]	Luminance signal mixed gain
08h	DAMP_FLT[1:0]	Damping coil signal LPF cut-off frequency
	Y_FLT[1:0]	Luminance signal LPF cut-off frequency
	DAMP_GAIN[3:0]	Damping coil signal amplifier gain
	Y_GAIN[3:0]	Luminance signal amplifier gain

**OPERATION(continued)**

**1. Control mode(continued)**

3) Register function table(continued)

Address	Register name / Bit wide	Function
09h	ENABLE	Enable / Disable CTL
	VD_POL	VD_IN polarity selection
	ASWMODE[1:0]	ADCIN pin connection selection
	PID_CLIP[3:0]	PWM max-duty control
	PWM_IRIS[2:0]	PWM frequency of IRIS block output
	DT_ADJ_IRIS[1:0]	Dead time correction of IRIS block output
	TESTEN1	Test mode enable 1
0Ah	IRSAD[9:0]	ADC output for IRIS (read only)
0Ch	START1[9:0]	Pulse 1 start time
0Dh	WIDTH1[11:0]	Pulse 1 width
	P1EN	Pulse 1 output enable
0Eh	START2[9:0]	Pulse 2 start time
0Fh	WIDTH2[5:0]	Pulse 2 width
	P2EN	Pulse 2 output enable
20h	PLS_SEL[3:0]*	Monitor output selection
	TESTEN2	Test mode enable 2
21h	DUTY_TEST	IRIS test mode 1
	TGT_IN_TEST[9:0]	IRIS test mode 2

Please refer to a application note for details.

**APPLICATIONS INFORMATION**

**1. Notes**

1) Power-on and Supply voltage

When supplying to AVDD3 (Pin 4), VDD5 (Pin 15), and DVDD (Pin 26), or raising supply voltage for these pins, set the rising speed of supply voltage to less than 0.05 V/ $\mu$ s. AVDD3, VDD5, and DVDD can be powered on in any sequence.

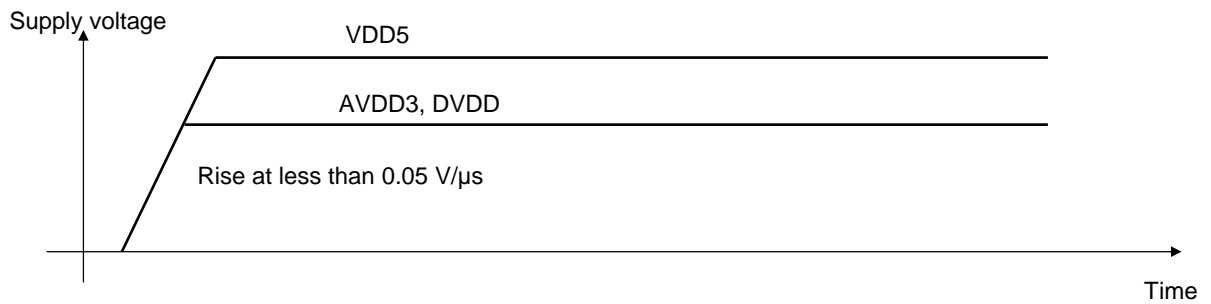

Connections to VREF and CREF

To VREF (Pin 2), do not connect other than recommended capacitor and damp coil.

To CREF (Pin 3), do not connect other than recommended capacitor.

TYPICAL CHARACTERISTICS CURVES

1, High-speed response of luminance change.

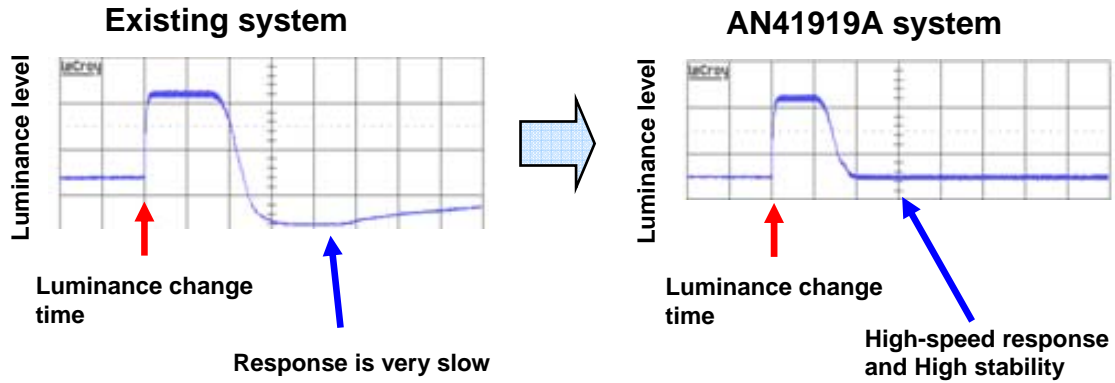

2, Characteristic of supply voltage monitor.

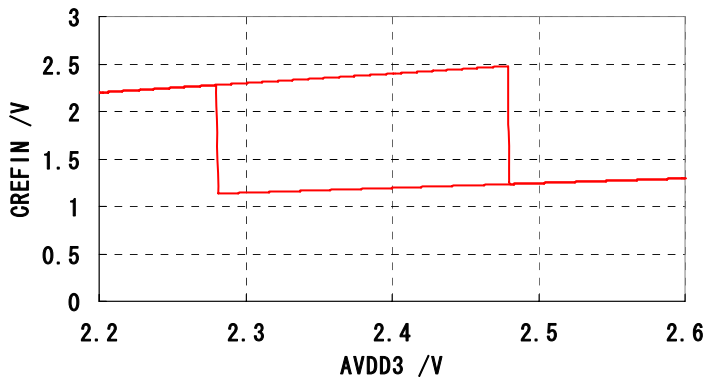

(1) AVDD3  
 Operation voltage : 2.28V  
 Return voltage : 2.48V

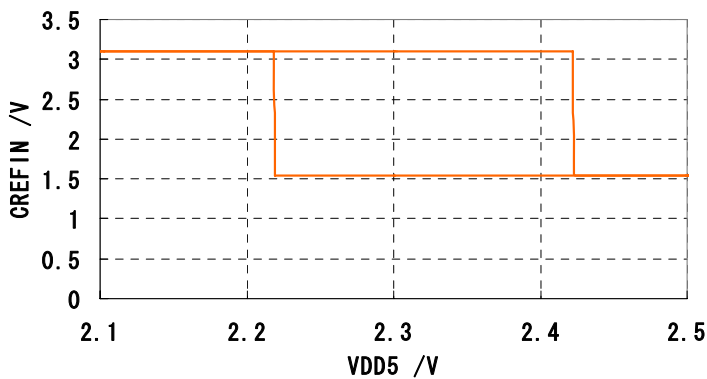

(2) VDD5  
 Operation voltage : 2.22V  
 Return voltage : 2.42V



PACKAGE INFORMATION ( Reference Data )

Package Code: \*QFN044-P-0606D

unit:mm

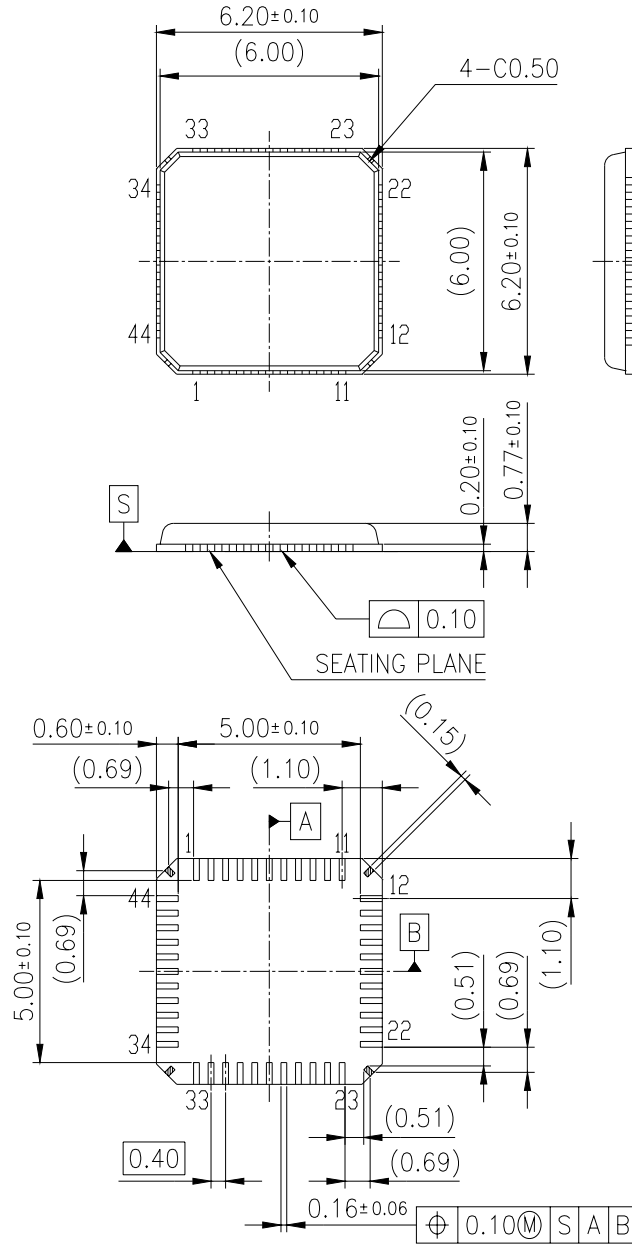

Body Material	: Br / Sb Free Epoxy Resin
Lead Material	: Cu Alloy
Lead Finish Method	: Pd Plating

**IMPORTANT NOTICE**

1. The products and product specifications described in this book are subject to change without notice for modification and/or improvement. At the final stage of your design, purchasing, or use of the products, therefore, ask for the most up-to-date Product Standards in advance to make sure that the latest specifications satisfy your requirements.
2. When using the LSI for new models, verify the safety including the long-term reliability for each product.
3. When the application system is designed by using this LSI, be sure to confirm notes in this book.  
Be sure to read the notes to descriptions and the usage notes in the book.
4. The technical information described in this book is intended only to show the main characteristics and application circuit examples of the products. No license is granted in and to any intellectual property right or other right owned by Panasonic Corporation or any other company. Therefore, no responsibility is assumed by our company as to the infringement upon any such right owned by any other company which may arise as a result of the use of technical information de-scribed in this book.
5. This book may be not reprinted or reproduced whether wholly or partially, without the prior written permission of our company.
6. This LSI is intended to be used for general electronic equipment [IP camera and network camera].  
Consult our sales staff in advance for information on the following applications: Special applications in which exceptional quality and reliability are required, or if the failure or malfunction of this LSI may directly jeopardize life or harm the human body.  
Any applications other than the standard applications intended.
  - (1) Space appliance (such as artificial satellite, and rocket)
  - (2) Traffic control equipment (such as for automobile, airplane, train, and ship)
  - (3) Medical equipment for life support
  - (4) Submarine transponder
  - (5) Control equipment for power plant
  - (6) Disaster prevention and security device
  - (7) Weapon
  - (8) Others : Applications of which reliability equivalent to (1) to (7) is required
 It is to be understood that our company shall not be held responsible for any damage incurred as a result of or in connection with your using the LSI described in this book for any special application, unless our company agrees to your using the LSI in this book for any special application.
7. This LSI is neither designed nor intended for use in automotive applications or environments unless the specific product is designated by our company as compliant with the ISO/TS 16949 requirements.  
Our company shall not be held responsible for any damage incurred by you or any third party as a result of or in connection with your using the LSI in automotive application, unless our company agrees to your using the LSI in this book for such application.
8. If any of the products or technical information described in this book is to be exported or provided to non-residents, the laws and regulations of the exporting country, especially, those with regard to security export control, must be observed.
9. Please use this product in compliance with all applicable laws and regulations that regulate the inclusion or use of controlled substances, including without limitation, the EU RoHS Directive. Our company shall not be held responsible for any damage incurred as a result of your using the LSI not complying with the applicable laws and regulations.

**USAGE NOTES**

1. When designing your equipment, comply with the range of absolute maximum rating and the guaranteed operating conditions (operating power supply voltage and operating environment etc.). Especially, please be careful not to exceed the range of absolute maximum rating on the transient state, such as power-on, power-off and mode-switching. Otherwise, we will not be liable for any defect which may arise later in your equipment.

Even when the products are used within the guaranteed values, take into the consideration of incidence of break down and failure mode, possible to occur to semiconductor products. Measures on the systems such as redundant design, arresting the spread of fire or preventing glitch are recommended in order to prevent physical injury, fire, social damages, for example, by using the products.

2. Comply with the instructions for use in order to prevent breakdown and characteristics change due to external factors (ESD, EOS, thermal stress and mechanical stress) at the time of handling, mounting or at customer's process. When using products for which damp-proof packing is required, satisfy the conditions, such as shelf life and the elapsed time since first opening the packages.
3. Pay attention to the direction of LSI. When mounting it in the wrong direction onto the PCB (printed-circuit-board), it might smoke or ignite.
4. Pay attention in the PCB (printed-circuit-board) pattern layout in order to prevent damage due to short circuit between pins. In addition, refer to the Pin Description for the pin configuration.
5. Perform a visual inspection on the PCB before applying power, otherwise damage might happen due to problems such as a solder-bridge between the pins of the semiconductor device. Also, perform a full technical verification on the assembly quality, because the same damage possibly can happen due to conductive substances, such as solder ball, that adhere to the LSI during transportation.
6. Take notice in the use of this product that it might break or occasionally smoke when an abnormal state occurs such as output pin-VCC short (Power supply fault), output pin-GND short (Ground fault), or output-to-output-pin short (load short) .

And, safety measures such as an installation of fuses are recommended because the extent of the above-mentioned damage and smoke emission will depend on the current capability of the power supply.

7. The protection circuit is for maintaining safety against abnormal operation. Therefore, the protection circuit should not work during normal operation.  
  
Especially for the thermal protection circuit, if the area of safe operation or the absolute maximum rating is momentarily exceeded due to output pin to VCC short (Power supply fault), or output pin to GND short (Ground fault), the LSI might be damaged before the thermal protection circuit could operate.
8. Unless specified in the product specifications, make sure that negative voltage or excessive voltage are not applied to the pins because the device might be damaged, which could happen due to negative voltage or excessive voltage generated during the ON and OFF timing when the inductive load of a motor coil or actuator coils of optical pick-up is being driven.
9. The product which has specified ASO (Area of Safe Operation) should be operated in ASO
10. Verify the risks which might be caused by the malfunctions of external components.
11. Apply voltage from a low-impedance to power supply pins and connect a bypass capacitor to the LSI as near as possible.

## Request for your special attention and precautions in using the technical information and semiconductors described in this book

- (1) If any of the products or technical information described in this book is to be exported or provided to non-residents, the laws and regulations of the exporting country, especially, those with regard to security export control, must be observed.
- (2) The technical information described in this book is intended only to show the main characteristics and application circuit examples of the products. No license is granted in and to any intellectual property right or other right owned by Panasonic Corporation or any other company. Therefore, no responsibility is assumed by our company as to the infringement upon any such right owned by any other company which may arise as a result of the use of technical information described in this book.
- (3) The products described in this book are intended to be used for general applications (such as office equipment, communications equipment, measuring instruments and household appliances), or for specific applications as expressly stated in this book.  
Consult our sales staff in advance for information on the following applications:
  - Special applications (such as for airplanes, aerospace, automotive equipment, traffic signaling equipment, combustion equipment, life support systems and safety devices) in which exceptional quality and reliability are required, or if the failure or malfunction of the products may directly jeopardize life or harm the human body.It is to be understood that our company shall not be held responsible for any damage incurred as a result of or in connection with your using the products described in this book for any special application, unless our company agrees to your using the products in this book for any special application.
- (4) The products and product specifications described in this book are subject to change without notice for modification and/or improvement. At the final stage of your design, purchasing, or use of the products, therefore, ask for the most up-to-date Product Standards in advance to make sure that the latest specifications satisfy your requirements.
- (5) When designing your equipment, comply with the range of absolute maximum rating and the guaranteed operating conditions (operating power supply voltage and operating environment etc.). Especially, please be careful not to exceed the range of absolute maximum rating on the transient state, such as power-on, power-off and mode-switching. Otherwise, we will not be liable for any defect which may arise later in your equipment.  
Even when the products are used within the guaranteed values, take into the consideration of incidence of break down and failure mode, possible to occur to semiconductor products. Measures on the systems such as redundant design, arresting the spread of fire or preventing glitch are recommended in order to prevent physical injury, fire, social damages, for example, by using the products.
- (6) Comply with the instructions for use in order to prevent breakdown and characteristics change due to external factors (ESD, EOS, thermal stress and mechanical stress) at the time of handling, mounting or at customer's process. When using products for which damp-proof packing is required, satisfy the conditions, such as shelf life and the elapsed time since first opening the packages.
- (7) This book may be not reprinted or reproduced whether wholly or partially, without the prior written permission of our company.