

# AVIAQUIP

## AN502

### SCREW - MACHINE, DRILLED FILLISTER HEAD, FINE THREAD

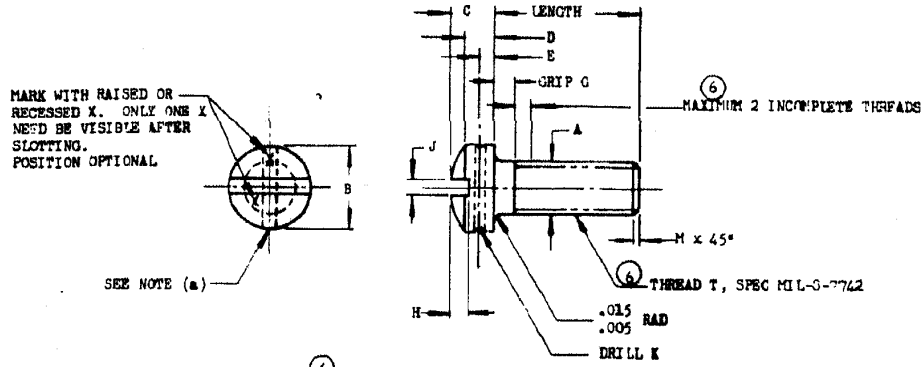

THREAD T	A	B DIA		C		D		E REF	G GRIP		H		J		K RILL +.004 -.001	M MAX
		MAX	MIN	MAX	MIN	MAX	MIN		MAX	MIN	MAX	MIN	MAX	MIN		
NO .1032NF3A 1/4-28-UNF-3A	.1900 .2500	.313 .414	.292 .389	.180 .237	.165 .219	.130 .170	.123 .161	.043 .062	.063 .078	.031 .046	.075 .102	.064 .087	.060 .075	.050 .064	.046 .062	.031 .031
5/16-24-UNF-3A	.3125	.518	.490	.295	.276	.211	.201	.078	.078	.046	.130	.110	.084	.072	.070	.047

LENGTH		DASH NUMBERS		
		NO. 10-32	1/4-28	5/16-24
1/4	+ 0	10-4		
3/8		10-6	416-6	
1/2		10-8	416-8	
5/8	- 1/32	10-10	416-10	
3/4		10-12	416-12	516-12
7/8	- 1/16	10-14	416-14	516-14
1		10-16	416-16	516-16
1-1/8		10-18	416-18	516-18
1-1/4		10-20	416-20	516-20
1-3/8	+ 0	10-22	416-22	516-22
1-1/2		10-24	416-24	516-24
1-5/8	- 1/16	10-26	416-26	516-26
1-3/4			416-28	516-28
1-7/8			416-30	516-30
2			416-32	516-32

MATERIAL : STEEL, SPEC AN-S-9, MIL-S-6050 OR OTHER STEEL MEETING THE SAME PHYSICAL REQUIREMENTS.

HEAT TREAT : 125,000 TO 145,000 PSI TENSILE STRENGTH, SPEC MIL-H-6875

FINISH : CADMIUM PLATE : SPEC QQ-P-416, TYPE 1, CLASS C.

SAMPLE OF PART NUMBER: AN502-10-10 = NO. 10-32 SCREW, 5/8 INCH LONG

PRODUCT INFORMATION AND PART NUMBERS SHOWN ON THESE PAGES ARE NOT GUARANTEED CORRECT BY AVIAQUIP PTY. LTD AND ARE SUBJECT TO CHANGE WITHOUT NOTICE.