

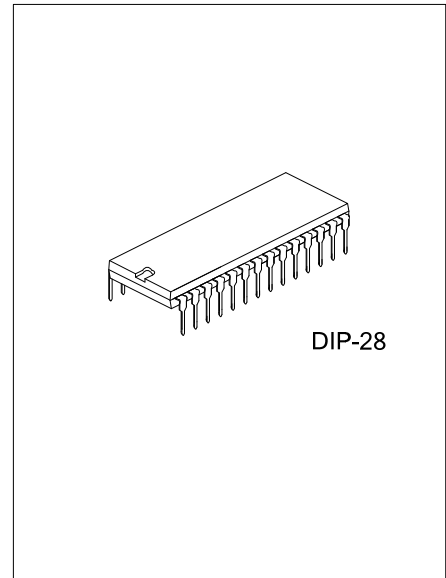

AN5151

LINEAR INTEGRATED CIRCUIT

TV VIF & SIF & DEFLECTION SYSTEM (FOR TV LARGE INTEGRATION)



DESCRIPTION

The UTC AN5151 is a monolithic integrated circuit containing all stage for the VIF,SIF and deflection of television receivers.

FEATURES

*Hight integrated technology makes it possible the integration of video IF circuit tuner AFC circuit sound. IF circuit and deflection.-jungle circuit on one single chip.

*supply voltage range:8V to 12V

FUNCTIONS

*IF Amplifier, IF AGC

*Video Amplifier, Video Detector

*Noise Canceller, Forward RF AGC

*Tuner AFT,SIF Amplifier

*Sound Detector, sync separation

*Vertical oscillation trigger and driver

*Horizontal oscillation driver and AFC

ORDERING INFORMATION

Ordering Number	Package	Packing
AN5151G-D28-T	DIP-28	Tube

<p>AN5151G-D28-T</p> <p>(1)Packing Type</p> <p>(2)Package Type</p> <p>(3)Green Package</p>	<p>(1) T: Tube</p> <p>(2) D28: DIP-28</p> <p>(3) G: Halogen Free and Lead Free</p>
--------------------------------------------------------------------------------------------	------------------------------------------------------------------------------------

MARKING INFORMATION

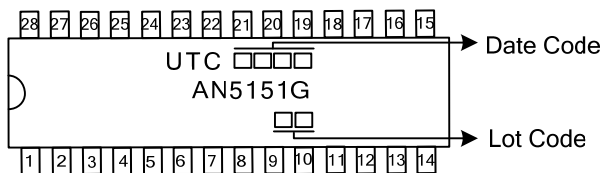

■ PIN CONFIGURATION

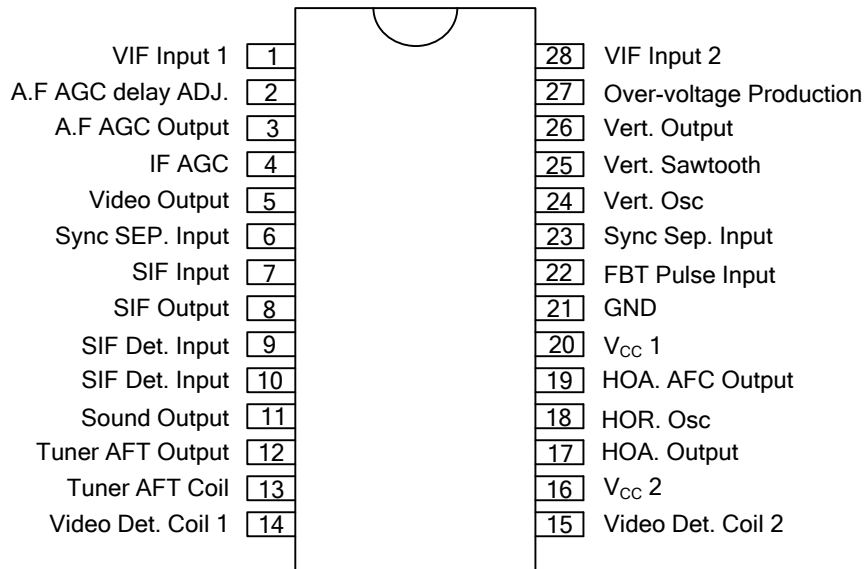

■ ABSOLUTE MAXIMUM RATING

PARAMETER	SYMBOL	RATINGS	UNIT
Supply Voltage	V_{CC1}	12	V
Supply Current	I20	85	mA
	I16	15	mA
Circuit Voltage	V2,3,4,24	0	V
	V8	5.5 ~ 0	V
	V13	4.2 ~ 0	V
	V17	0	V
Circuit Current	I5,6,11,23,26	+0.3 ~ -10	mAp-p
	I19	+0.6 ~ -0.6	mAp-p
	I25	+10 ~ 0	mAp-p
	I17	+10 ~ -4	mAp-p
Power Dissipation	P_D	1100	mW
Operating Temperature	T_{OPR}	-20 to +70	°C
Storage Temperature	T_{STG}	-40 to 125	°C

Note: Absolute maximum ratings are those values beyond which the device could be permanently damaged. Absolute maximum ratings are stress ratings only and functional device operation is not implied.

■ ELECTRICAL CHARACTERISTICS

PARAMETER	SYMBOL	TEST CONDITIONS	MIN	TYP	MAX	UNIT
VIDEO SECTION						
Video Det. Output	V_O	$m = 87.5\%$	2.0	2.3	2.6	Vp-p
Input Sensitivity	S_{VI}	$V_O = -3dB$		50	55	dB μ
Maximum Input	V_{max}	$V_O > +0dB$	105	110		dB
S/N Ratio	S/N	$V_I = 80dB\mu$	51	56		dB
Differential Gain	DG	$m = 87.5\%$		4	8	%
Differential Phase	DP	$m = 87.5\%$		3	6	°C
Video frequency Characteristics	G_{vf}	$V_O = -3dB$	4.5	6.0	8.0	MHz
Sync. Peak Voltage	V_P		1.9	2.3	2.7	V
Noise inverter output level	V_{NT}		1.0	1.4	1.8	V
Noise inverter capture level	V_{NI}		3.0	4.0	5.0	V
Sound IF Output	V_{sif}	P/S=20dB	100	104	107	dB μ
Input Resistor	R_{IN}	$f = 45.75MHz$	0.8	1.0	1.2	k Ω
Input Capacitor	C_{IN}	$f = 45.75MHz$	3.0	3.4	3.8	pF
Output Resistor	$R_o(\text{pin } 5)$	$f = 500kHz$	30	50	150	Ω
RF AGC Gain	$G_{RF(AGC)}$	$f = 10kHz, V_4 = 5mV$	36	42	48	dB
RF AGC Maximum Voltage	$V3_{max}$		8.2	8.8	9.4	V
RF AGC Minimum Voltage	$V3_{min}$		3.6	4.2	4.8	V
AFT Center Voltage	V2		4.0	5.4	6.0	V
AFT SW Operating Voltage	$V_{AFT(SW)}$	$R_S = 10k\Omega$	0.5	2.6	3.0	V
AFT Maximum Output Voltage	$V12_{max}$		8.5	9.6	10.0	V
AFT Minimum Output Voltage	$V12_{min}$		0	0.7	1.2	V
Selection Sensitivity		$R_L = 68k\Omega / 82k\Omega$	30	50	90	mV/kHz

■ ELECTRICAL CHARACTERISTICS (Cont.)

PARAMETER	SYMBOL	TEST CONDITIONS	MIN	TYP	MAX	UNIT
SOUND SECTION						
Sound Det. Output	V_O	$f_o = 4.5\text{MHz}$, $f_m = 400\text{Hz}$, $\Delta f = \pm 25\text{kHz}$, $V_i = 100\text{mVrms}$	200	300	440	mVrms
Input Limit Voltage	V_{I_lim}	$f_o = 4.5\text{MHz}$, $f_m = 400\text{Hz}$, $\Delta f = \pm 25\text{kHz}$		280	450	μVrms
Total Harmonic distortion	THD	$f_o = 4.5\text{MHz}$, $f_m = 400\text{Hz}$, $\Delta f = \pm 25\text{kHz}$, $V_i = 100\text{mVrms}$		0.6	1.0	%
AM Rejection ratio	AMR	$f_o = 4.5\text{MHz}$, $f_m = 400\text{Hz}$, $\Delta f = \pm 25\text{kHz}$, $V_i = 100\text{mVrms}$	43	55		dB
Input Impedance	R17	$f = 4.5\text{MHz}$	6	20	100	k Ω
	C17		1.3	4.3	7.3	pF
Detector input impedance	R9	$f = 4.5\text{MHz}$	2.0	3.0	4.0	k Ω
	C9		2.1	5.1	8.1	pF
	R10		50	200		k Ω
	C10		2.9	3.4	3.9	pF
DEFLECTION SECTION						
Sync separation horizontal pulse width 1	tsYNC1	Video input 2.5Vp-p APL=50%, $V_{CC1}=10\text{V}$	4.8	5.1	5.4	μs
Sync separation horizontal pulse width 2	tsYNC2	Video input 1.0Vp-p APL=50%, $V_{CC1}=10\text{V}$	4.9	5.2	5.5	μs
Horizontal AFC Horizontal pulse width 1	tsYNC3	Video input 2.5Vp-p APL=50%, $V_{CC1}=10\text{V}$	4.8	5.1	5.4	μs
Horizontal AFC Horizontal pulse width 2	tsYNC4	Video input 1.0Vp-p APL=50%, $V_{CC1}=10\text{V}$	4.9	5.2	5.5	μs
Vertical Osc, start supply voltage	Vvos	$f_{vo}=50\sim 70\text{Hz}$, Output=0.7Vp-p			6	V
Vertical free runing frequency	fvo	$R_{osc}=31.5\text{k}\Omega$	57	60	63	Hz
Vertical Osc. Pulse width	tvo	$R_{osc}=31.5\text{k}\Omega$	470	650	830	μs
Vertical full in Range	fv(pull)	$V_{CC1}=12\text{V}, 8\text{V}$ $\Delta f_{vo}/V_{CC} = f_{vo}(12\text{V}) - f_{vo}(8\text{V})$	0	1.0	1.3	Hz
Horizontal OSC. Start supply voltage	Vhos	$f_{ho}=10\sim 20\text{kHz}$, output=1Vp-p pin 16 Voltage			5	V
Horizontal Osc. Frequency	fho	$R_{osc}=21\text{k}\Omega$	15.0	15.75	16.25	kHz
Horizontal Osc. Pulse width	tho	$R_{osc}=21\text{k}\Omega$	23	25	29	μs
Horizontal OSC Control Sensitivity		$\Delta I_1 = \pm 100\mu\text{A}$ input Variable Osc. Frequency Variable	73	81	89	Hz/ μA
Phase Det. Sensitivity	μP	TV input 2Vp-p, $R(u)=31.4\text{k}\Omega$, $\mu=V_{19}\times 10$	13.5	16.5	19.5	$\mu\text{A}/\mu\text{S}$
X-ray protector operation voltage	V27		0.81	0.87	0.93	V
X-ray protector input resistor	R27		16	19	22.5	k Ω

■ TYPICAL APPLICATION CIRCUIT

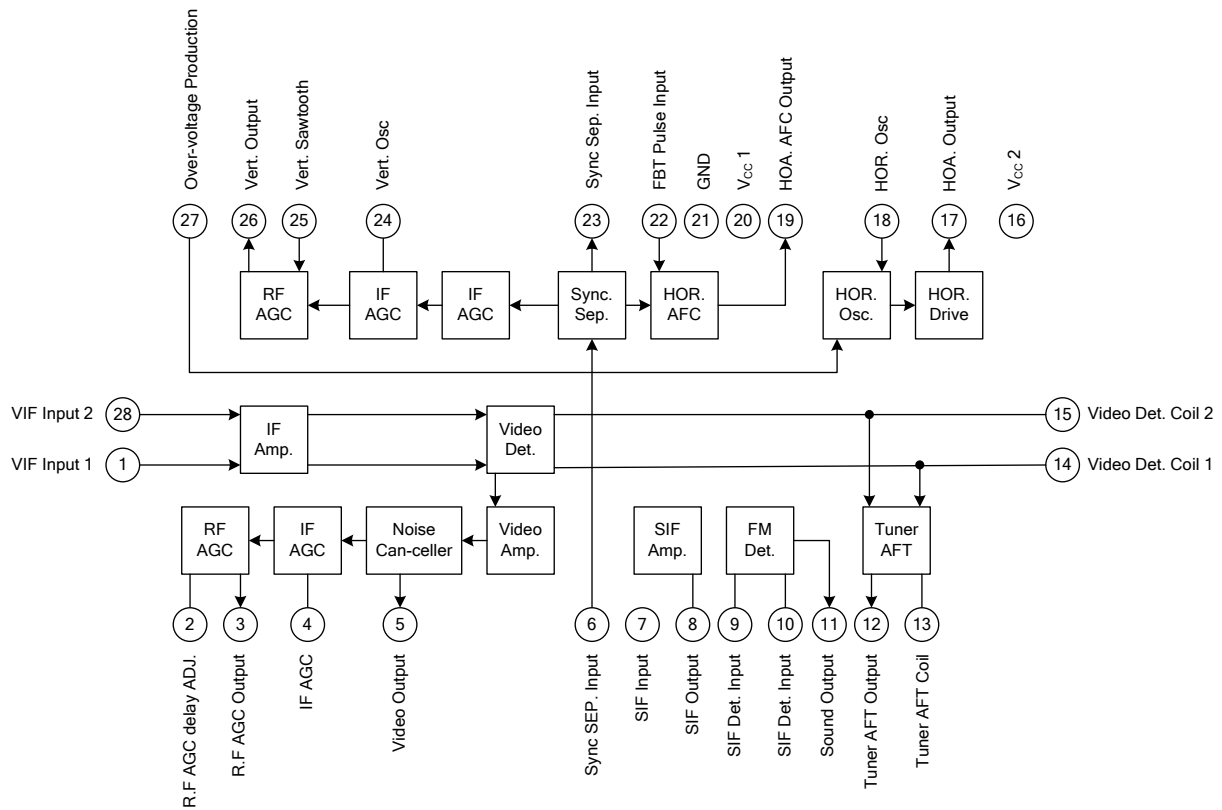

UTC assumes no responsibility for equipment failures that result from using products at values that exceed, even momentarily, rated values (such as maximum ratings, operating condition ranges, or other parameters) listed in products specifications of any and all UTC products described or contained herein. UTC products are not designed for use in life support appliances, devices or systems where malfunction of these products can be reasonably expected to result in personal injury. Reproduction in whole or in part is prohibited without the prior written consent of the copyright owner. The information presented in this document does not form part of any quotation or contract, is believed to be accurate and reliable and may be changed without notice.