

AN5385K

Contour correction IC

■ Overview

The AN5385K is an IC which conducts contour correction for luminance signal and color difference signal. It corresponds to all broadcasting systems of PAL, NTSC and SECAM. Fewer external parts enables the TV sets to be less cost and high picture quality.

■ Features

- Black side contour emphasis and white side shoot elimination circuit are built in (for anti-blooming)
- Transient correction of color difference signal (color missing improvement)
- Red gamma correction circuit built in
- Wider band of signal processing (Y: 7 MHz/−3 dB, Color difference: 3 MHz/−3 dB)
- Delay time is identical for both Y and color difference.
- Delay amount switch is built in
- Delay line and coupling condenser built in

■ Applications

- Color TV, wide TV

■ Block Diagram

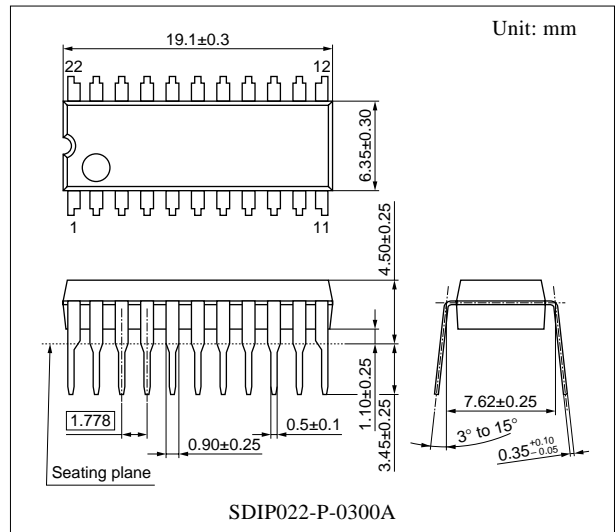
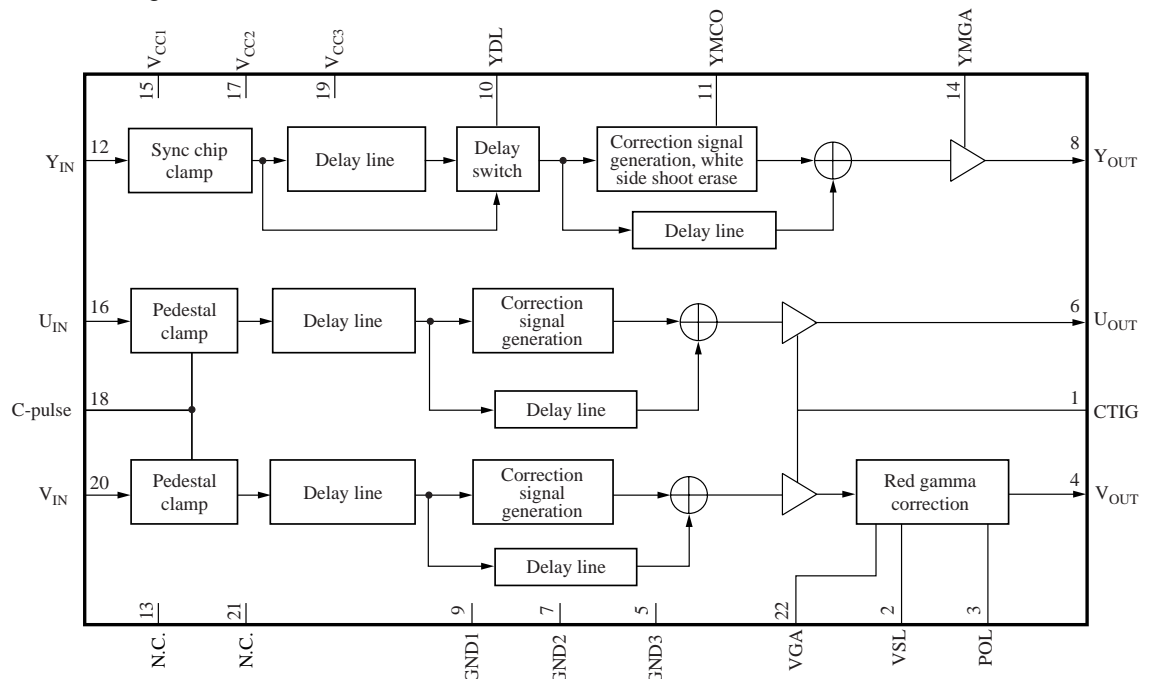

Pin Descriptions

Pin No.	Description	Pin No.	Description
1	CTI control pin	12	Y-signal input pin
2	Red gamma folding point control pin	13	N.C.
3	V-polarity switch pin	14	Signal VM control pin
4	V-signal output pin	15	V _{CC1} (Y)
5	GND3 (V)	16	U-signal input pin
6	U-signal output pin	17	V _{CC2} (U)
7	GND2 (U)	18	Clamp pulse input pin
8	Y-signal delay time switch pin	19	V _{CC3} (V)
9	GND1 (Y)	20	V-signal input pin
10	Y-signal delay time switch pin	21	N.C.
11	Signal VM coring control pin	22	Red gamma control pin

Absolute Maximum Ratings

Parameter	Symbol		Rating	Unit
Supply voltage	V _{CC}	V _{CC1} / V _{CC2} / V _{CC3}	10.0	V
Supply current	I _{CC}	I _{CC1}	25.0	mA
		I _{CC2}	25.0	
		I _{CC3}	25.0	
Power dissipation *2	P _D		750	mW
Operating ambient temperature *1	T _{opr}		-20 to +70	°C
Storage temperature *1	T _{stg}		-55 to +150	°C

Note) *1: Except for the operating ambient temperature and storage temperature, all ratings are for T_a = 25°C.

*2: The power dissipation shown is the value for T_a = 70°C.

Recommended Operating Range

Parameter	Symbol	Range	Unit
Supply voltage	V _{CC1} / V _{CC2} / V _{CC3}	8.1 to 9.9	V

Note) On/off for V_{CC1} / V_{CC2} and V_{CC3} should be done simultaneously.

Be careful for static electricity damage of pin 6.

Electrical Characteristics at T_a = 25°C

Parameter	Symbol	Conditions	Min	Typ	Max	Unit
DC characteristics						
Circuit current 1	I _{CC1}	V _{CC1} = V _{CC2} = V _{CC3} = 9.0 V	11	14	17	mA
Circuit current 2	I _{CC2}	V _{CC1} = V _{CC2} = V _{CC3} = 9.0 V	13	16	19	mA
Circuit current 3	I _{CC3}	V _{CC1} = V _{CC2} = V _{CC3} = 9.0 V	14	17	20	mA
Circuit voltage 1	V ₃₋₅	V _{CC1} = V _{CC2} = V _{CC3} = 9.0 V	4.0	4.5	5.0	V
Circuit voltage 2	V ₄₋₅	V _{CC1} = V _{CC2} = V _{CC3} = 9.0 V	4.0	4.5	5.0	V

■ Electrical Characteristics at $T_a = 25^\circ\text{C}$ (continued)

Parameter	Symbol	Conditions	Min	Typ	Max	Unit
DC characteristics (continued)						
Circuit voltage 3	V_{6-7}	$V_{CC1} = V_{CC2} = V_{CC3} = 9.0\text{ V}$	2.5	3.0	3.5	V
Circuit voltage 4	V_{8-9}	$V_{CC1} = V_{CC2} = V_{CC3} = 9.0\text{ V}$	5.0	5.5	6.0	V
Circuit voltage 5	V_{12-9}	$V_{CC1} = V_{CC2} = V_{CC3} = 9.0\text{ V}$	3.2	3.6	4.0	V
Circuit voltage 6	V_{16-7}	$V_{CC1} = V_{CC2} = V_{CC3} = 9.0\text{ V}$	5.4	6.0	6.6	V
Circuit voltage 7	V_{20-5}	$V_{CC1} = V_{CC2} = V_{CC3} = 9.0\text{ V}$	5.4	6.0	6.6	V
Y-system						
Y_{OUT} output gain	G_Y	Y_{IN} : 2 MHz, 1.0 V[p-p] Sine wave input, YDL = 9.0 V, VMCO = 2.0 V VMGA = 2.0 V	-2.0	0.0	2.0	dB
I/O delay time 11	T_{Y11}	Y_{IN} : 500 kHz, 0.3 V[p-p] Sine wave input, YDL = 0.0 V, VMCO = 2.0 V VMGA = 2.0 V	200	280	360	ns
I/O delay time 12	T_{Y12}	Y_{IN} : 2 MHz, 0.3 V[p-p] Sine wave input, YDL = 0.0 V, VMCO = 2.0 V VMGA = 2.0 V	200	280	360	ns
I/O delay time 21	T_{Y21}	Y_{IN} : 500 kHz, 0.3 V[p-p] Sine wave input, YDL = 9.0 V, VMCO = 2.0 V VMGA = 2.0 V	500	600	700	ns
I/O delay time 22	T_{Y22}	Y_{IN} : 2 MHz, 0.3 V[p-p] Sine wave input, YDL = 9.0 V, VMCO = 2.0 V VMGA = 2.0 V	500	600	700	ns
Coring characteristics 1	e_{co1}	Y_{IN} : 2 MHz, 0.2 V[p-p] Sine wave input, YDL = 9.0 V, VMGA = 4.0 V VMCO: 2.0 V	0.2	2.3	4.4	dB
Coring characteristics 2	Δe_{co}	Y_{IN} : 2 MHz, 0.2V[p-p] Sin wave input, YDL = 9.0 V, VMGA = 4.0 V VMCO: 4.0 V	0.4	2.4	4.4	dB
Signal VM characteristics 1	e_{VM1}	Y_{IN} : 2 MHz, 1.0 V[p-p] Sine wave input, YDL = 9.0 V, VMCO = 3.0 V VMGA = 3.0 V	1.0	2.5	4.0	dB
Signal VM characteristics 2	Δe_{VM}	Y_{IN} : 2 MHz, 1.0 V[p-p] Sine wave input, YDL = 9.0 V, VMCO = 3.0 V VMGA = 4.0 V	3.0	4.0	5.0	dB
Y_{OUT} frequency characteristics 1	ΔA_{Y1}	Y_{OUT} : Measure at 7 MHz point, 0 dB: 1 MHz, YDL = 0.0 V VMCO = 2.0 V, VMGA = 2.0 V	-3.0	—	—	dB
Y_{OUT} frequency characteristics 2	ΔA_{Y2}	Y_{OUT} : Measure at 7 MHz point, 0 dB: 1 MHz, YDL = 9.0 V VMCO = 2.0 V, VMGA = 2.0 V	-3.0	—	—	dB

■ Electrical Characteristics at $T_a = 25^\circ\text{C}$ (continued)

Parameter	Symbol	Conditions	Min	Typ	Max	Unit
U-system						
U_{OUT} output gain	G_U	U_{IN} : 500 kHz, 0.5 V[p-p] Sine wave input, C-pulse = 0 V, CTIG = 2.0 V	5.0	6.0	7.0	dB
CTI characteristics 1	e_{UCTI1}	U_{IN} : 500 kHz, 0.5 V[p-p] Sine wave input, C-pulse = 0 V, CTIG = 3.0 V	5.0	6.0	7.0	dB
CTI characteristics 2	Δe_{UCTI}	U_{IN} : 500 kHz, 0.5 V[p-p] Sine wave input, C-pulse = 0 V, CTIG = 4.0 V	2.4	3.3	4.2	dB
U_{OUT} frequency characteristics	Δa_U	U_{OUT} : Measure at 3 MHz point, 0 dB: 500 kHz, C-pulse = 0 V CTIG = 2.0 V	-3.0	—	—	dB
V-system						
V_{OUT} output gain	G_V	V_{IN} : 500 kHz, 0.5 V[p-p] Sine wave input, C-pulse = 0 V CTIG = 2.0 V, VGA = 3.0 V VSL = 5.0 V, POL = 9.0 V	4.9	6.0	7.1	dB
CTI characteristics 3	e_{VCTI3}	V_{IN} : 500 kHz, 0.5 V[p-p] Sine wave input, C-pulse = 0 V CTIG = 3.0 V, VGA = 3.0 V VSL = 5.0 V, POL = 9.0 V	4.7	5.7	6.7	dB
CTI characteristics 4	Δe_{VCTI}	V_{IN} : 500 kHz, 0.5 V[p-p] Sine wave input, C-pulse = 0 V, CTIG = 4.0 V, VGA = 3.0 V VSL = 5.0 V, POL = 9.0 V	1.7	2.6	3.5	dB
V_{OUT} frequency characteristics	Δa_V	V_{OUT} : Measure at 3 MHz point, 0 dB: 500 kHz, C-pulse = 0 V CTIG = 2.0 V, VGA = 3.0 V VSL = 5.0 V, POL = 9.0 V	-3.0	—	—	dB
YU relative delay time	T_{YU}	Y_{IN} : 500 kHz, 1.0 V[p-p], U_{IN} : 500 kHz, 0.5 V[p-p], YDL = 9.0 V VMCO = 2.0 V, VMGA = 2.0 V C-pulse = 0.0 V, CTIG = 2.0 V	-6	37	80	ns
YV relative delay time	T_{YV}	Y_{IN} : 500 kHz, 1.0 V[p-p] V_{IN} : 500 kHz, 0.5 V[p-p] YDL = 9.0 V, VMCO = 2.0 V VMGA = 2.0 V, CTIG = 2.0 V C-pulse = 0.0 V, VGA = 3.0 V VSL = 5.0 V, POL = 9.0 V	-16	27	70	ns
UV relative delay time	T_{UV}	U_{IN} : 500 kHz, 0.5 V[p-p], V_{IN} : 500 kHz, 0.5 V[p-p], CTIG = 2.0 V, C-pulse = 0.0 V VGA = 3.0 V, VSL = 5.0 V POL = 9.0 V	-96	-10	76	ns

■ Electrical Characteristics at $T_a = 25^\circ\text{C}$ (continued)

Parameter	Symbol	Conditions	Min	Typ	Max	Unit
V-system (continued)						
Red gamma bending point variation 11	e_{VGS11}	V_{IN} : 500 kHz, 0.5 V[p-p] Sine wave input, C-pulse = 0 V, CTIG = 3.0 V VGA = 5.0 V, VSL = 3.0 V POL = 9.0 V	-3.6	0.0	3.6	dB
Red gamma bending point variation 12	Δe_{VGS1}	V_{IN} : 500 kHz, 0.5 V[p-p] Sine wave input, C-pulse = 0 V, CTIG = 3.0 V VGA = 5.0 V, VSL = 5.0 V POL = 9.0 V	2.5	6.0	9.5	dB
Red gamma bending point variation 21	e_{VGS21}	V_{IN} : 500 kHz, 0.5 V[p-p] Sine wave input, C-pulse = 0 V, CTIG = 3.0 V VGA = 5.0 V, VSL = 3.0 V POL = 0.0 V	-3.6	0.0	3.6	dB
Red gamma bending point variation 22	Δe_{VGS2}	V_{IN} : 500 kHz, 0.5 V[p-p] Sine wave input, C-pulse = 0 V, CTIG = 3.0 V VGA = 5.0 V, VSL = 5.0 V POL = 0.0 V	1.5	5.0	8.5	dB
Red gamma control 11	e_{VGE11}	V_{IN} : 500 kHz, 0.5 V[p-p] Sine wave input, C-pulse = 0 V, CTIG = 3.0 V VGA = 3.0 V, VSL = 3.0 V POL = 9.0 V	4.5	5.5	6.5	dB
Red gamma control 12	Δe_{VGE1}	V_{IN} : 500 kHz, 0.5 V[p-p] Sine wave input, C-pulse = 0 V, CTIG = 3.0 V VGA = 5.0 V, VSL = 3.0 V POL = 9.0 V	2.5	6.0	9.5	dB
Red gamma control 21	e_{VGE21}	V_{IN} : 500 kHz, 0.5 V[p-p] Sine wave input, C-pulse = 0 V, CTIG = 3.0 V VGA = 3.0 V, VSL = 3.0 V POL = 0.0 V	4.5	5.5	6.5	dB
Red gamma control 22	Δe_{VGE2}	V_{IN} : 500 kHz, 0.5 V[p-p] Sine wave input, C-pulse = 0 V, CTIG = 3.0 V VGA = 5.0 V, VSL = 3.0 V POL = 0.0 V	1.5	5.0	8.5	dB

• Design reference data

Note) The characteristics listed below are theoretical values based on the IC design and are not guaranteed.

Parameter	Symbol	Conditions	Min	Typ	Max	Unit
Y_{OUT} supply voltage variation	Δe_{YIVcc}	Output DC level difference between V_{CC} (max.) and V_{CC} (min.)	0.8	1.2	1.6	V
U_{OUT} supply voltage variation	Δe_{UIVcc}	Output DC level difference between V_{CC} (max.) and V_{CC} (min.)	0.4	0.8	1.2	V
V_{OUT} supply voltage variation	Δe_{VIVcc}	Output DC level difference between V_{CC} (max.) and V_{CC} (min.)	0.4	0.8	1.2	V

■ Terminal Equivalent Circuits

Pin No.	Equivalent circuit	Description
1		<p>CTI control pin:</p> <ul style="list-style-type: none"> Varies the CTI correction gain <p>2 V: Correction off 3 V: Correction amount center (approx. 6 dB) 4 V: Correction amount maximum (approx. 12 dB)</p> <ul style="list-style-type: none"> Recommended use range: 2 V to 4 V
2		<p>Red gamma folding point control pin:</p> <ul style="list-style-type: none"> Varies the red gamma correction slice level <p>3 V: The folding point comes closest to the pedestal 5 V: The folding point is kept farthest from the pedestal</p> <ul style="list-style-type: none"> Recommended use range: 3 V to 5 V
3		<p>V-polarity changeover pin:</p> <ul style="list-style-type: none"> Changes over the input/output polarity of V-signal <p>Threshold value: 4.5 V 0 V: negative polarity 9 V: positive polarity</p>
4		<p>V-signal output pin:</p> <ul style="list-style-type: none"> To output the V-signal in which a correction signal has been added to V-signal (R-Y) input from pin 20 <ul style="list-style-type: none"> Output level: 1.0 V[p-p] (where, 0.5 V[p-p] of U-signal input)

■ Terminal Equivalent Circuits (continued)

Pin No.	Equivalent circuit	Description
5	—	GND3 pin: • GND pin of V-system
6		U-signal output pin: • To output U-signal output in which a correction signal has been added to U-signal (B-Y) input from pin 16 • Output level: 1.0 V[p-p] (where, 0.5 V[p-p] of U-signal input)
7	—	GND2 pin: • GND pin of U-system
8		Y-signal output pin: • To output Y-signal in which a correction signal has been added to the Y-signal inputted from pin 12 • Output level: Synchronous negative 1.0 V[p-p] (where, 1.0 V[p-p] of Y-signal input)
9	—	GND1 pin: • Y-system GND pin
10		Y-signal delay time changeover pin: • Changes over Y-signal delay time Threshold voltage: 0.7 V 9 V: Total 600 ns delay 0 V: Total 280 ns delay
11		Signal VM coring control pin: • To control VM signal coring volume 2 V: No coring 4 V: Maximum coring (approx. 8%) • Recommended usable range: 2 V to 4 V

■ Terminal Equivalent Circuits (continued)

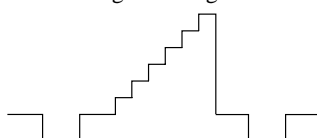
Pin No.	Equivalent circuit	Description
12		<p>Y-signal output pin:</p> <ul style="list-style-type: none"> To input video brightness signal  <ul style="list-style-type: none"> Input level: Synchronous negative: 1.0 V[p-p] Recommended use method: Add a coupling capacitor (2.2 μ) to the input signal in series.
13	—	<p>N.C. pin:</p> <ul style="list-style-type: none"> Ground
14		<p>Signal VM control pin:</p> <ul style="list-style-type: none"> To control correction gain of signal VM <p>2 V: correction off 4 V: Maximum correction (approx. 6 dB)</p> <ul style="list-style-type: none"> Recommended use range: 2 V to 4 V
15		<p>Power supply pin (Y-system):</p> <p>Operating supply voltage range: 9 V (allowance: ±10%)</p>
16		<p>U-signal input pin:</p> <ul style="list-style-type: none"> To input the U-signal (B-Y) of color difference. <ul style="list-style-type: none"> Input level: 0.5 V[p-p]
17		<p>Power supply pin (U-system):</p> <p>Operating supply voltage range: 9 V (allowance: ±10%)</p>

■ Terminal Equivalent Circuits (continued)

Pin No.	Equivalent circuit	Description
18		<p>Clamp pulse input pin:</p> <ul style="list-style-type: none"> To input a clamp pulse. Input SCP or H-sync signal of 0 V to 5 V <p>SCP H-sync signal</p> <p>4.7 V 5.0 V</p> <p>2.4 V</p> <p>Threshold voltage: 3.5 V</p>
19		<p>Power supply pin (V-system):</p> <p>Operating power supply range: 9 V (allowance: ±10%)</p>
20		<p>V-signal input pin:</p> <ul style="list-style-type: none"> To input the V-signal (R-Y) of color difference <ul style="list-style-type: none"> Input level: 0.5 V[p-p]
21		<p>N.C. pin:</p> <ul style="list-style-type: none"> Ground
22		<p>Red gamma control pin:</p> <ul style="list-style-type: none"> To control correction gain of red gamma <p>3 V: Off 5 V: Maximum</p> <ul style="list-style-type: none"> Recommended use range: 3 V to 5 V