

AN5764N

Horizontal picture position control IC for CRT monitor

■ Overview

The AN5764N is an IC for CRT monitor horizontal picture position control. The picture position can be controlled by DC voltage, and the adoption of fin-attached SIL 7-pin package contributes to the rationalization of monitor set.

■ Features

- CRT monitor position control
- Built-in low voltage output circuit
- Built-in DC control circuit

■ Applications

- CRT monitor

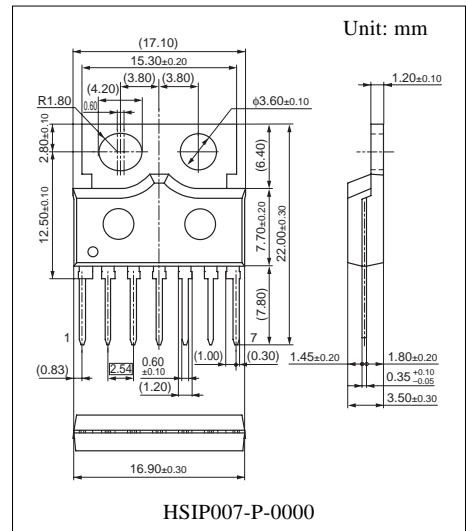

■ Block Diagram

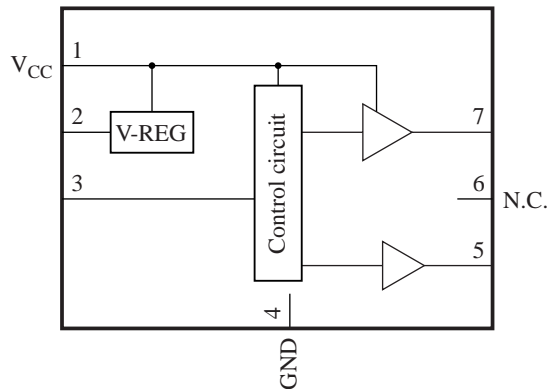

■ Pin Descriptions

Pin No.	Description
1	V_{CC}
2	Constant voltage output (3 V)
3	Control input
4	GND
5	Out1 (Positive output)
6	N.C.
7	Out2 (Negative output)

Note) The fin is at the same potential as GND.

■ Absolute Maximum Ratings

Parameter	Symbol	Rating	Unit
Supply voltage	V_{CC}	8.0	V
Supply current	I_{CC}	500	mA
Power dissipation *2	P_D	1 400	mW
Operating ambient temperature *1	T_{opr}	-20 to +75	°C
Storage temperature *1	T_{stg}	-55 to +150	°C

Note) *1: Except for the operating ambient temperature and storage temperature, all ratings are for $T_a = 25^\circ\text{C}$.

*2: The power dissipation shown is for the independent IC without a heat sink at $T_a = 75^\circ\text{C}$. (Refer to "■ Application Note".)

■ Recommended Operating Range

Parameter	Symbol	Range	Unit
Supply voltage	$V_{CC1,2}$	5 to 7	V
Control input	V_{3-4}	0 to V_2	V
Out1 output maximum output current	I_{5max}	-400 to +400	mA
Out2 output maximum output current	I_{7max}	-400 to +400	mA
Constant voltage maximum output current	I_{2max}	-2.0 to +0.02	mA

Note) For the circuit currents, '+' denotes current flowing into the IC, and '-' denotes current flowing out of the IC.

■ Electrical Characteristics at $T_a = 25^\circ\text{C}$

Parameter	Symbol	Conditions	Min	Typ	Max	Unit
Circuit current pin 1	I_{CC1}	$V_{CC} = 5.5\text{ V}$, $V_3 = 1.5\text{ V}$ At load (R_L) = Open	7	14	28	mA
Circuit voltage pin 2	V_{2-4}	$V_{CC} = 5.5\text{ V}$, $V_3 = 1.5\text{ V}$ At load (R_L) = Open	2.8	3.0	3.2	mA
Circuit voltage pin 5	V_{5-4}	$V_{CC} = 5.5\text{ V}$, $V_3 = 1.5\text{ V}$ At load (R_L) = Open	2.3	2.6	2.9	V
Circuit voltage pin 7	V_{7-4}	$V_{CC} = 5.5\text{ V}$, $V_3 = 1.5\text{ V}$ At load (R_L) = Open	2.3	2.6	2.9	V
Circuit voltage pin 5-7	V_{5-7}	$V_{CC} = 5.5\text{ V}$, $V_3 = 1.5\text{ V}$ At load (R_L) = Open	-0.35	0.0	0.35	V
Out1 high-level output voltage	V_{5HI}	$V_{CC} = 5.5\text{ V}$, $V_3 = 3\text{ V}$ At $R_L = 7.5\ \Omega$ connection	4.2	4.5	4.7	V
Out1 low-level output voltage	V_{5LOW}	$V_{CC} = 5.5\text{ V}$, $V_3 = 0\text{ V}$ At $R_L = 7.5\ \Omega$ connection	1.3	1.8	2.3	V
Out2 high-level output voltage	V_{7HI}	$V_{CC} = 5.5\text{ V}$, $V_3 = 0\text{ V}$ At $R_L = 7.5\ \Omega$ connection	4.3	4.5	4.7	V
Out2 low-level output voltage	V_{7LOW}	$V_{CC} = 5.5\text{ V}$, $V_3 = 3\text{ V}$ At $R_L = 7.5\ \Omega$ connection	1.3	1.8	2.3	V
Output voltage difference min.	V_{5-7min}	$V_{CC} = 5.5\text{ V}$, $V_3 = 0\text{ V}$ At $R_L = 7.5\ \Omega$ connection	-3.2	-2.5	-2.2	V

■ Electrical Characteristics at $T_a = 25^\circ\text{C}$ (continued)

Parameter	Symbol	Conditions	Min	Typ	Max	Unit
Output voltage difference typ.	$V_{5-7\text{typ}}$	$V_{CC} = 5.5\text{ V}$, $V_3 = 1.5\text{ V}$ At $R_L = 7.5\ \Omega$ connection	-0.4	0.0	0.4	V
Output voltage difference max.	$V_{5-7\text{max}}$	$V_{CC} = 5.5\text{ V}$, $V_3 = 3\text{ V}$ At $R_L = 7.5\ \Omega$ connection	2.2	2.5	3.2	V

• Design reference data

Note) The characteristics listed below are theoretical values based on the IC design and are not guaranteed.

Parameter	Symbol	Conditions	Min	Typ	Max	Unit
Control input pin circuit current max.	$I_{3\text{min}}$	Current of pin 3, at $V_{CC} = 5.5\text{ V}$, $V_4 = 0\text{ V}$	-100	-10	0	μA
Control input pin circuit current typ.	$I_{3\text{max}}$	Current of pin 3, at $V_4 = 0.5\text{ V}$ to 3 V	-50	-5	0	μA
Out1 maximum output current (Positive)	$I_{5\text{max}}$	Output current of pin 5, at $V_{CC} = 5.5\text{ V}$	300	—	400	mA
Out1 maximum output current (Negative)	$I_{5\text{min}}$	Output current of pin 5, at $V_{CC} = 5.5\text{ V}$	-400	—	-300	mA
Out2 maximum output current (Positive)	$I_{7\text{max}}$	Output current of pin 7, at $V_{CC} = 5.5\text{ V}$	300	—	400	mA
Out2 maximum output current (Negative)	$I_{7\text{min}}$	Output current of pin 7, at $V_{CC} = 5.5\text{ V}$	-400	—	-300	mA

■ Terminal Equivalent Circuits

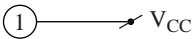
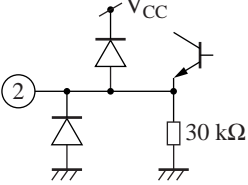
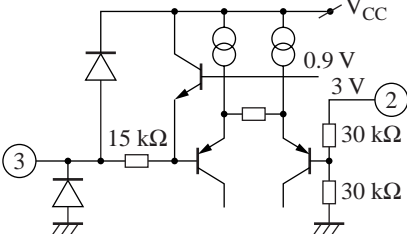
Pin No.	Equivalent circuit	Description
1		<p>V_{CC}: Power supply pin</p> <p>DC 5.5 V (typ.) application</p>
2		<p>Constant voltage output: 3 V constant-voltage output</p> <p>DC 3 V</p>
3		<p>Control input: Input pin for control</p> <p>Output voltage balances at ($V_3 = \frac{1}{2} V_2$)</p> <p>0 V to 3 V variable</p>

■ Terminal Equivalent Circuits (continued)

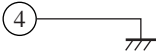
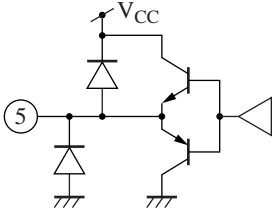
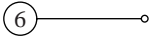
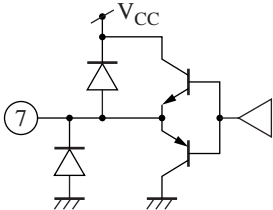
Pin No.	Equivalent circuit	Description
4		GND: GND (Earth) pin Fin becomes the same potential, too. 0 V
5		Out1 output: Output pin Outputs the same polarity as pin 3 control voltage DC 1.2 V to 4.3 V
6		N.C.: N.C. pin
7		Out2 output: Output pin Outputs the reverse polarity of pin 3 control voltage. DC 1.2 V to 4.3 V

■ Application Circuit Examples

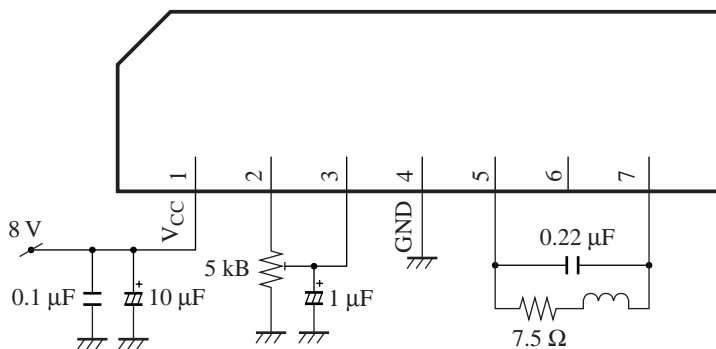

■ Application Note

- $P_D - T_a$ curve of HSIP007-P-0000

