

# AN5765

## CRT heater voltage control IC

### ■ Overview

The AN5765 is an IC for CRT heater voltage control. The incorporation of 4 values of heater voltage change-over output circuit, 5 V power supply and reset circuit for microcomputer, and the adoption of SIP 7-pin package with fin can realize the rationalization and power saving of the set.

### ■ Features

- Incorporating 4 values changeover output circuit
- Incorporating 5 V constant voltage output
- Incorporating reset function
- Incorporating current protection and thermal protection circuit

### ■ Applications

- CRT monitors

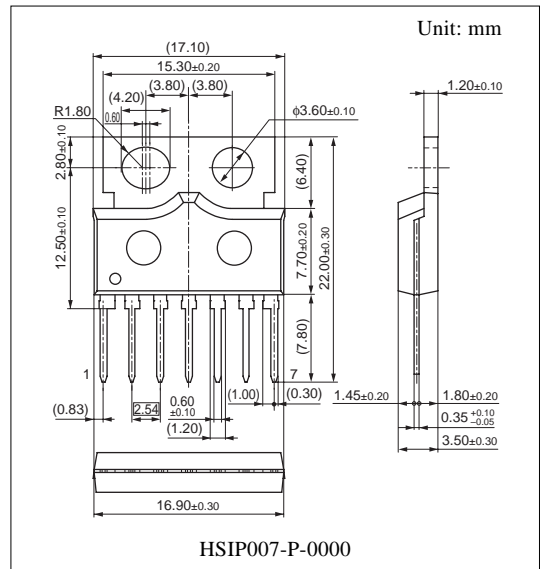

### ■ Block Diagram

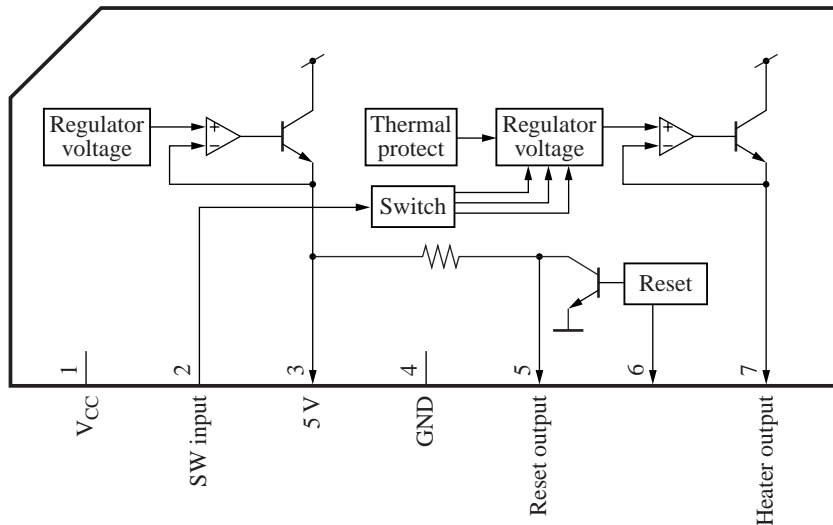

## ■ Pin Descriptions

Pin No.	Description
1	V <sub>CC</sub>
2	SW input
3	Regulator output (5 V)
4	GND
5	Reset output
6	Capacitor for delay
7	Heater output

Note) Fin has the same potential as GND

## ■ Absolute Maximum Ratings

Parameter	Symbol	Rating	Unit
Supply voltage	V <sub>CC</sub>	12.0	V
Supply current	I <sub>CC</sub>	2 000	mA
Power dissipation *2	P <sub>D</sub>	1 400	mW
Operating ambient temperature *1	T <sub>opr</sub>	-20 to +75	°C
Storage temperature *1	T <sub>stg</sub>	-55 to +150	°C

Note) \*1: Except for the operating ambient temperature and storage temperature, all ratings are for T<sub>a</sub> = 25°C.

\*2: The power dissipation shown is for the IC package at T<sub>a</sub> = 75°C.

## ■ Recommended Operating Range

Parameter	Symbol	Range	Unit
Supply voltage	V <sub>CC</sub>	7.5 to 11.0	V
SW input	V <sub>2-4</sub>	0 to V <sub>3</sub>	V
Regulator output maximum output current	I <sub>3max</sub>	-400 to +0.1	mA
Heater output maximum output current	I <sub>7max</sub>	-1 000 to +0.05	mA

Note) '+' denotes current flowing into the IC, and '-' denotes current flowing out of the IC.

## ■ Electrical Characteristics at T<sub>a</sub> = 25°C

Parameter	Symbol	Conditions	Min	Typ	Max	Unit
Circuit current pin 1	I <sub>CC</sub>	V <sub>CC</sub> = 8 V, load (R3, R7) open	2	4.5	7	mA
Circuit voltage pin 2	V <sub>2-4</sub>	V <sub>CC</sub> = 8 V, R3 = 1 kΩ, R7 = 500 Ω	1.7	2.0	2.3	V
Circuit voltage pin 3	V <sub>3-4</sub>	V <sub>CC</sub> = 8 V, R3 = 1 kΩ, R7 = 500 Ω	4.75	5.0	5.15	V
Circuit voltage pin 5	V <sub>5-4</sub>	V <sub>CC</sub> = 8 V, R3 = 1 kΩ, R7 = 500 Ω	4.75	5.0	5.15	V
Circuit voltage pin 7	V <sub>7-4</sub>	V <sub>CC</sub> = 8 V, R3 = 1 kΩ, R7 = 500 Ω	4.25	4.5	4.75	V
Heater output off voltage	V <sub>7-4OFF</sub>	V <sub>CC</sub> = 8 V, V <sub>2</sub> = 0 V, R3 = 1 kΩ, R7 = 500 Ω	0	—	0.1	V

### ■ Electrical Characteristics at $T_a = 25^\circ\text{C}$ (continued)

Parameter	Symbol	Conditions	Min	Typ	Max	Unit
Regulator output voltage	$V_{3RL}$	$V_{CC} = 8\text{ V}$ , $R3 = 20\ \Omega$ , $R7 = 10\ \Omega$	4.7	5.0	5.1	V
Heater output voltage high	$V_{7HI}$	$V_{CC} = 8\text{ V}$ , $V_2 = 5\text{ V}$ , $R3 = 20\ \Omega$ , $R7 = 10\ \Omega$	6.15	6.40	6.65	V
Heater output voltage mid.	$V_{7MID}$	$V_{CC} = 8\text{ V}$ , $V_2 = 3\text{ V}$ , $R3 = 20\ \Omega$ , $R7 = 10\ \Omega$	4.95	5.2	5.45	V
Heater output voltage low	$V_{7LO}$	$V_{CC} = 8\text{ V}$ , $V_2 = 2\text{ V}$ , $R3 = 20\ \Omega$ , $R7 = 10\ \Omega$	4.25	4.5	4.75	V
Heater output voltage off	$V_{7OFF}$	$V_{CC} = 8\text{ V}$ , $V_2 = 0\text{ V}$ , $R3 = 20\ \Omega$ , $R7 = 10\ \Omega$	0	—	0.1	V
Delay capacitor discharge current	$I_{6C}$	$V_{CC} = 5.0\text{ V}$ , $V_6 = 1\text{ V}$	1	5	—	mA
Delay capacitor charge current	$I_{6D}$	$V_{CC} = 6.0\text{ V}$ , $V_6 = 1\text{ V}$	-15	-8.5	-4	$\mu\text{A}$
Reset output voltage low	$V_{5LO}$	$V_{CC} = 8\text{ V}$ , $V_6 = 3.3\text{ V}$	0	—	0.15	V
Reset output voltage high	$V_{5HI}$	$V_{CC} = 8\text{ V}$ , $V_6 = 4.5\text{ V}$	4.7	5.0	5.1	V

#### • Design reference data

Note) The characteristics listed below are theoretical values based on the IC design and are not guaranteed.

Parameter	Symbol	Conditions	Min	Typ	Max	Unit
Heater output operation start supply voltage	$V_{OP7}$	$V_{CC}$ voltage at which $V_7$ becomes 0 V to 4.5 V.	6.1	6.35	6.5	V
Delay capacitor charge start regulator voltage	$V_{OP3}$	Regulator voltage at which pin 6 becomes low to high.	4.4	4.6	4.8	V
Delay capacitor discharge start regulator voltage	$V_{OF3}$	Regulator voltage at which pin 6 becomes high to low.	3.9	4.1	4.3	V
Reset output operation stop regulator voltage	$V_{OFF3}$	Regulator voltage at which pin 5 becomes high to low.	3.9	4.1	4.3	V

### ■ Terminal Equivalent Circuits

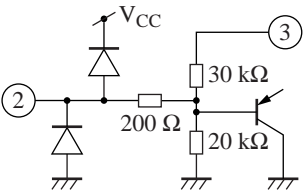
Pin No.	Equivalent circuit	Description
1		$V_{CC}$ : Power supply pin DC 8 V (typ.) application
2		SW input: SW input pin for changing over heater output (pin 7) voltage Changeover from DC 0 V to 5 V

### ■ Terminal Equivalent Circuits (continued)

Pin No.	Equivalent circuit	Description															
3		Regulator output: 5 V constant voltage output DC 5 V															
4		GND: GND (grounding) pin Fin is also in the same potential. 0 V															
5		Reset output: Pin for reset output Pin voltage becomes high at regulator output (pin 3) 4.6 V or more. <div style="text-align: right;"> </div>															
6		Capacitor for delay: Capacitor pin for reset output delay Approx. 50 ms delay with $C = 0.1\mu\text{F}$ connection <div style="text-align: right;"> </div>															
7		Heater output: Constant voltage output pin for heater Voltage can be changed over by SW input (pin 2). <table style="margin-left: auto; margin-right: auto;"> <thead> <tr> <th>DC</th> <th>Pin 2</th> <th>Pin 7</th> </tr> </thead> <tbody> <tr> <td></td> <td>5 V</td> <td>6.5 V</td> </tr> <tr> <td></td> <td>3 V</td> <td>5.2 V</td> </tr> <tr> <td></td> <td>2 V</td> <td>4.5 V</td> </tr> <tr> <td></td> <td>0 V</td> <td>0 V</td> </tr> </tbody> </table>	DC	Pin 2	Pin 7		5 V	6.5 V		3 V	5.2 V		2 V	4.5 V		0 V	0 V
DC	Pin 2	Pin 7															
	5 V	6.5 V															
	3 V	5.2 V															
	2 V	4.5 V															
	0 V	0 V															

■ Technical Information

1.  $P_D - T_a$  curves of HSIP007-P-0000

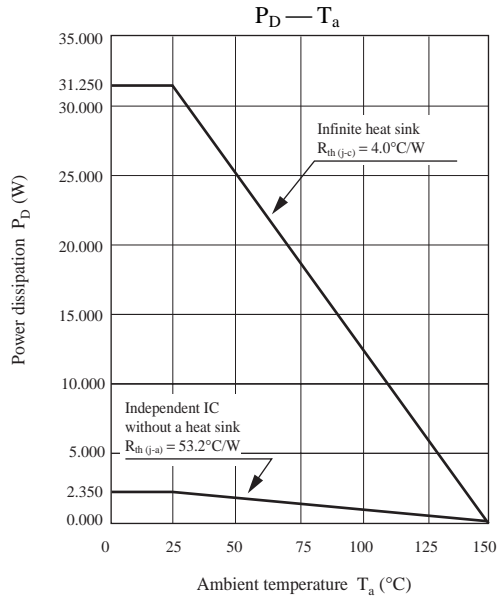

2. Main characteristics

1) Heater output voltage control characteristic (typical value)

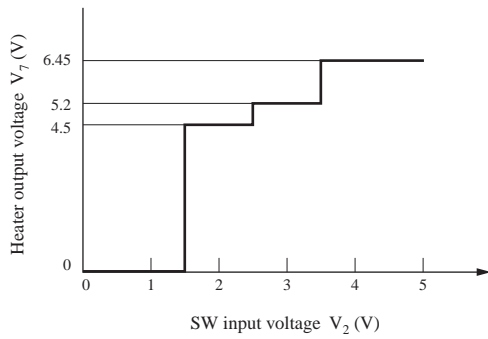

2) Supply voltage characteristics (typical value)

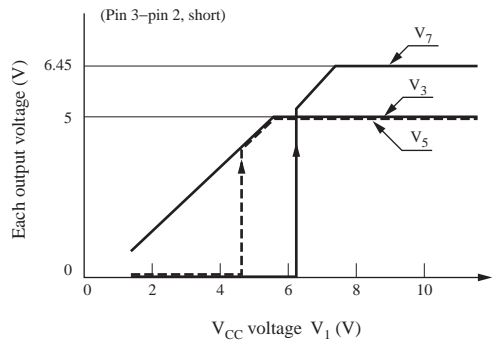

3) Timing relationship of regulator output voltage vs. reset output

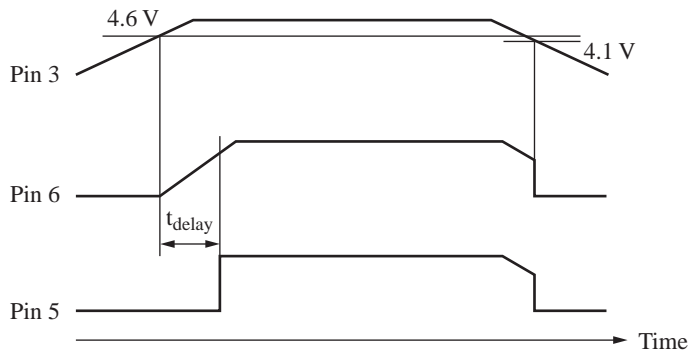

■ Technical Information (continued)

3. Operational explanation

- 1) Temperature protection circuit is built in.  
 The circuit operates at approx. 150°C (typ.) and pin 7 output becomes low-level (0 V).  
 If the temperature falls due to the output current decrease, the protection circuit turns off and pin 7 returns to the high-level again.

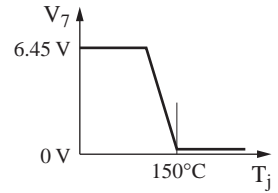

- 2) Pin 3 and pin 7 are equipped with current limiter circuit.  
 The limiter circuit operates at;  
 $I_3 \leq -400 \text{ mA}$   
 $I_7 \leq -1\ 000 \text{ mA}$   
 The current value is not guaranteed value since the value fluctuates due to dispersion and temperature characteristic.

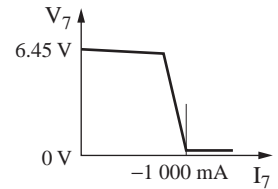
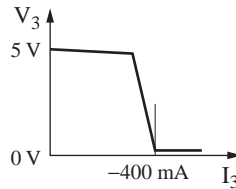

- 3) Pin 2 (SW input) is internally biased.  
 Pin 2 is biased at approx. 2 V when open. Pin 2 can be biased at approx. 3 V if 22 kΩ resistor is connected between pin 2 and pin 3 (5 V). However, take sufficient care to its absolute value fluctuation since the built-in resistor of IC has its dispersion and temperature dependency.

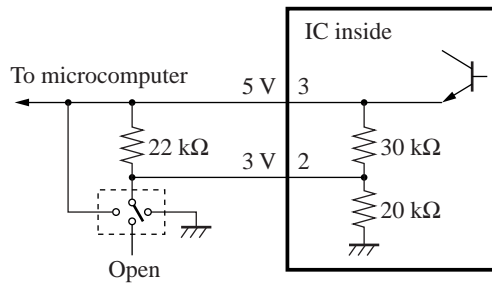

- 4) The Reset output becomes Low (0.15 V or less) by pin 3 voltage (at V<sub>3</sub> ≤ 4.1 V).  
 If V<sub>CC</sub> is turned off prior to regulator output, regulator output once becomes high (0.7 V) at a voltage of 0.7 V or less but there is no problem in terms of characteristics.

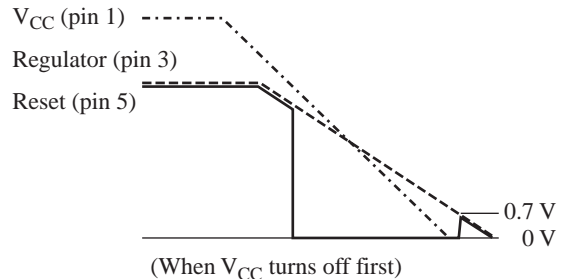
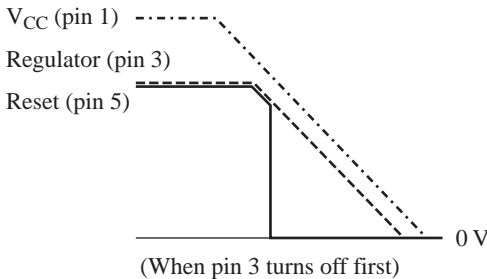

■ Application Example

1. Application system example

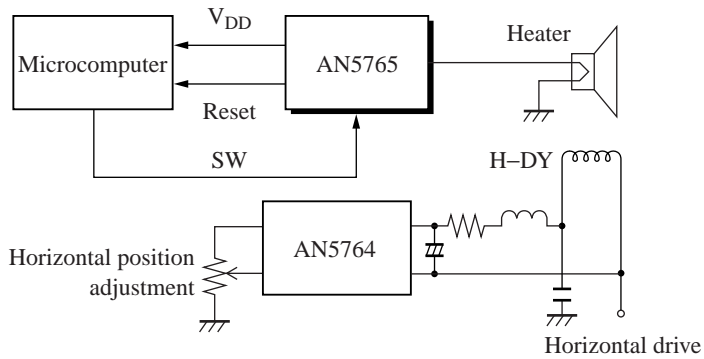

2. Application circuit example

