

# AN5767K

## Synchronizing signal processing IC

### ■ Overview

The AN5767K is a synchronizing signal processing IC with built-in frequency divider circuit for horizontal and vertical synchronizing signal. Input signal is outputted after being divided by two.

### ■ Features

- Built-in dividing-by-two circuit for horizontal synchronizing signal
- Built-in dividing-by-two circuit for vertical synchronizing signal
- On/off switch function of dividing output
- Gain control function of dividing output

### ■ Applications

- CRT monitors

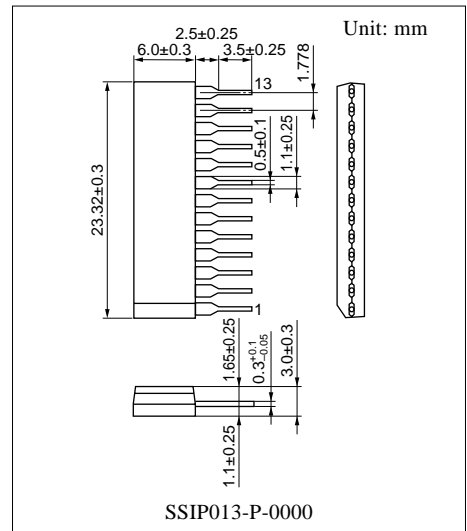

### ■ Block Diagram

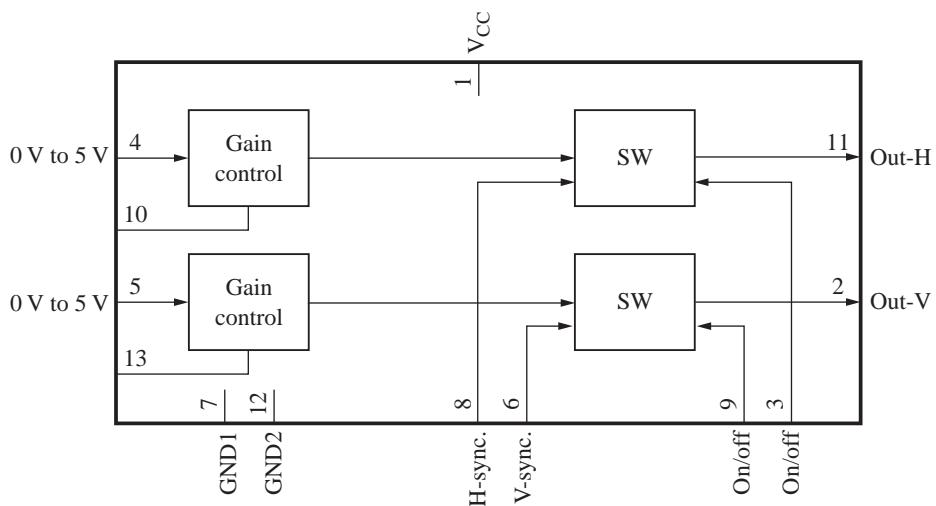

### ■ Pin Descriptions

Pin No.	Description	Pin No.	Description
1	Power supply 12 V( $V_{CC}$ )	8	H-sync. input
2	Freq.-divided output1 output	9	Freq.-divided output1 on/off
3	Freq.-divided output2 on/off	10	Freq.-divided output2 control resistor
4	Freq.-divided output2 control input	11	Freq.-divided output2 output
5	Freq.-divided output1 control input	12	GND2
6	V-sync. input	13	Freq.-divided output1 control resistor
7	GND1		

### ■ Absolute Maximum Ratings

Parameter	Symbol	Rating	Unit
Supply voltage	$V_{CC}$	13.5	V
Supply current	$I_{CC}$	25	mA
Power dissipation *2	$P_D$	337.5	mW
Operating ambient temperature *1	$T_{opr}$	-25 to +75	°C
Storage temperature *1	$T_{stg}$	-55 to +150	°C

Note) \*1: Except for the operating ambient temperature, and storage temperature, all ratings are for  $T_a = 25^\circ\text{C}$ .

\*2: The power dissipation shown is for the IC package in free air at  $T_a = 75^\circ\text{C}$ .

### ■ Recommended Operating Range

Parameter	Symbol	Range	Unit
Supply voltage	$V_{CC}$	10.8 to 13.2	V

### ■ Electrical Characteristics at $T_a = 25^\circ\text{C}$

Parameter	Symbol	Conditions	Min	Typ	Max	Unit
Circuit current	$I_{CC}$	$V_{CC} = 12\text{ V}$	4.8	5.9	7.2	mA
Circuit voltage 1	$V_{10(1)}$	$V_{CC} = 12\text{ V}, V_4 = 0\text{ V}$	-0.1	0.0	+0.1	V
Circuit voltage 2	$V_{10(2)}$	$V_{CC} = 12\text{ V}, V_4 = 5\text{ V}$	4.60	4.85	5.10	V
Circuit voltage 3	$V_{13(1)}$	$V_{CC} = 12\text{ V}, V_5 = 0\text{ V}$	-0.1	0.0	+0.1	V
Circuit voltage 4	$V_{13(2)}$	$V_{CC} = 12\text{ V}, V_5 = 5\text{ V}$	4.60	4.85	5.10	V
Freq.-divided output2 output current 1	$I_{11(1)}$	$V_{CC} = 12\text{ V}, V_3 = 5\text{ V}, V_4 = 5\text{ V}, R = 120\text{ k}\Omega$	30	40	50	$\mu\text{A}$
Freq.-divided output2 output current 2	$I_{11(2)}$	$V_{CC} = 12\text{ V}, V_3 = 0\text{ V}, V_4 = 5\text{ V}$	-5	0	+5	$\mu\text{A}$
Freq.-divided output2 output current 3	$I_{11(3)}$	$V_{CC} = 12\text{ V}, V_3 = 5\text{ V}, V_4 = 0\text{ V}$	-5	0	+5	$\mu\text{A}$
Freq.-divided output1 output current 1	$I_{2(1)}$	$V_{CC} = 12\text{ V}, V_5 = 5\text{ V}, V_9 = 5\text{ V}, R = 20\text{ k}\Omega$	-3.0	-2.5	-2.0	mA
Freq.-divided output1 output current 2	$I_{2(2)}$	$V_{CC} = 12\text{ V}, V_5 = 5\text{ V}, V_9 = 0\text{ V}$	-0.05	0	+0.05	mA
Freq.-divided output1 output current 3	$I_{2(3)}$	$V_{CC} = 12\text{ V}, V_5 = 0\text{ V}, V_9 = 5\text{ V}$	-0.05	0	+0.05	mA



■ Electrical Characteristics at  $T_a = 25^\circ\text{C}$  (continued)

• Design reference data

Note) The characteristics listed below are theoretical values based on the IC design and are not guaranteed.

Parameter	Symbol	Conditions	Min	Typ	Max	Unit
V-sync. dividing operation	$f_{V2}$	Pin 2 output frequency at pulse input to pin 6	—	$f_{V2} = 1/2f_{V6}$	—	Hz
H-sync. dividing operation	$f_{H11}$	Pin 11 output frequency at pulse input to pin 8	—	$f_{H11} = 1/2f_{H8}$	—	Hz
H-sync. dividing operation polarity between field	$f_{H11P}$	Pin 11 output frequency at pulse input to pin 6	—	$f_{H11} = 1/2f_{V6}$	—	Hz
V-sync. input	$V_{VS}$	Threshold value	—	2.5	—	V
H-sync. input	$V_{HS}$	Threshold value	—	2.5	—	V
V-sync. input	$f_{VIN}$	Operating frequency	30	—	200	Hz
H-sync. input	$f_{HIN}$	Operating frequency	15	—	150	kHz

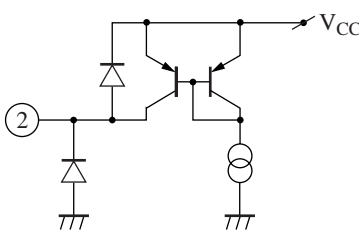
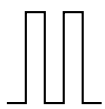
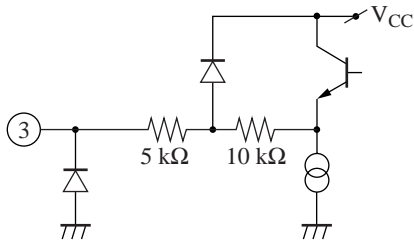
■ Terminal Equivalent Circuits

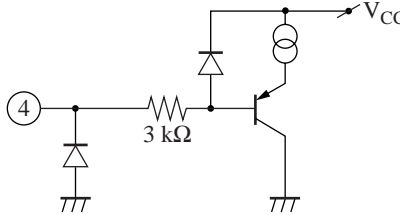
Pin No.	Equivalent circuit	Description	DC voltage (V)
1		Power supply 12 V ( $V_{CC}$ ): Supply pin Apply DC 12 V.	12
2		Freq.-divided output1: Freq.-divided output of V-sync. Outputted with current	
3		Freq.-divided output2 on/off: On/off changeover pin for freq.-divided output2 Off at 0 V.	
4		Freq.-divided output2 control input: Control input pin for freq.-divided output2 Apply DC 0 V to 5 V.	0 to 5

### ■ Terminal Equivalent Circuits (continued)

Pin No.	Equivalent circuit	Description	DC voltage (V)
5		<p>Freq.-divided output1 control input: Control input pin for freq.-divided output1 Apply DC 0 V to 5 V.</p>	0 to 5
6		<p>V-sync. input: Input pin for V-sync. Input negative polarity pulse.</p>	
7		<p>GND1: Ground pin</p>	0
8		<p>H-sync. input: Input pin for H-sync. Possible to input with both polarities, but phase will be delayed by a pulse width if pulse is inputted with positive polarity.</p>	
9		<p>Freq.-divided output1 on/off: On/off changeover pin for freq.-divided output1. Off at 0 V.</p>	
10		<p>Control resistor for freq.-divided output2: Resistor pin to determine freq.-divided output2 output current. Connect the resistor (recommended 120 kΩ) from this pin to GND.</p>	0 to 5

■ Terminal Equivalent Circuits (continued)

Pin No.	Equivalent circuit	Description	DC voltage (V)
11		Freq.-divided output2: Freq.-divided output of H-sync.. Outputted with current.	
12		GND2: Ground pin	0
13		Freq.-divided output1 control input: Resistor pin to determine freq.-divided output1 output current. Connect the resistor (recommended 20 kΩ) between this pin and GND.	0 to 5

■ Usage Notes

ECL is used for flip-flop circuit.

Use the condition of  $t_f \leq 10 \mu s$  and  $t_r \leq 10 \mu s$  for H-sync. and V-sync. respectively.

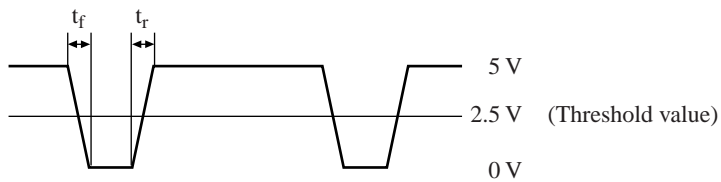

■ Application Circuit Example

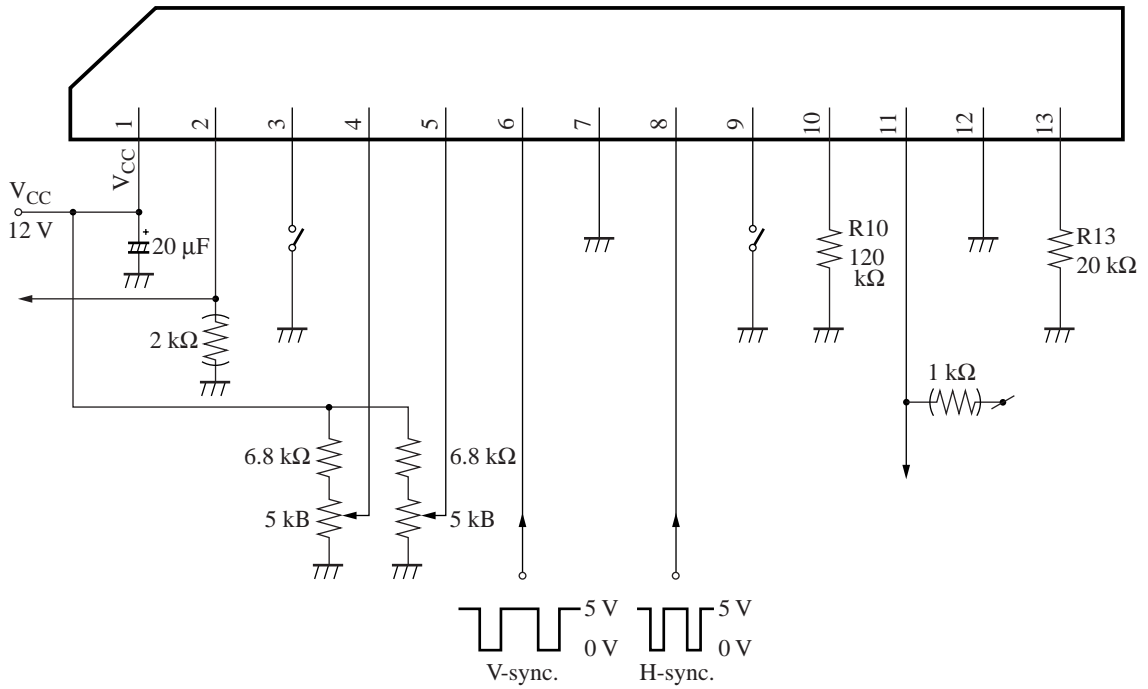

1. Recommended application conditions

Parameter	Symbol	Range	Unit
Freq.-divided output2 control input	$V_{4-7}$	0 to 6	V
Freq.-divided output1 control input	$V_{5-7}$	0 to 6	V
H-sync. input	$V_{8-7}$	0 to 6	V
V-sync. input	$V_{6-7}$	0 to 6	V
Freq.-divided output2 output current	$I_{11}$	0 to 1	mA
Freq.-divided output1 output current	$I_2$	-10 to 0	mA
Recommended resistance	R10	20k to 200k	$\Omega$
Recommended resistance	R13	10k to 200k	$\Omega$

2. Freq.-divided output2 on/off

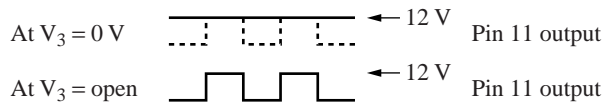

3. Freq.-divided output1 on/off

