

# AN5768

## TILT correction IC

### ■ Overview

The AN5768 is a rotation correction (TILT) IC for CRT monitor incorporating a driving transistor. It enables  $\pm 250$  mA (max.) DC current flow by connecting a coil between the output pins which operate with a reverse phase each other.

### ■ Features

- DC control input: 0 V to 5 V
- Output dynamic range: 1.2 V to 3.8 V
- Maximum output current:  $\pm 250$  mA

### ■ Applications

- CRT monitors

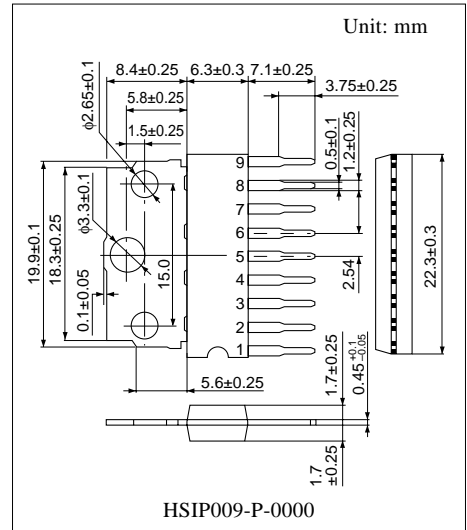

### ■ Block Diagram

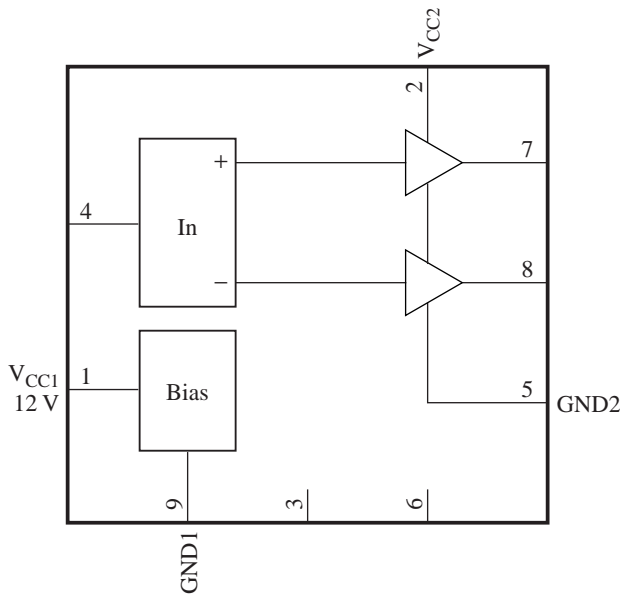

## ■ Pin Descriptions

Pin No.	Description
1	Supply voltage 12 V ( $V_{CC1}$ )
2	Output block supply voltage 7 V ( $V_{CC2}$ ), Protective resistor is needed.
3	N.C.
4	TILT control input
5	Output block GND (GND2)
6	N.C.
7	TILT positive output
8	TILT negative output
9	GND (GND1)

## ■ Absolute Maximum Ratings

Parameter	Symbol	Rating	Unit
Supply voltage	$V_{CC1}$	13.5	V
	$V_{CC2}$	11.05	
Supply current	$I_{CC1}$	26	mA
	$I_{CC2}$	250	
Power dissipation *2	$P_D$	1 128	mW
Operating ambient temperature *1	$T_{opr}$	-25 to +75	°C
Storage temperature *1	$T_{stg}$	-55 to +150	°C

Note) 1. \*1: Except for the operating ambient temperature and storage temperature, all ratings are for  $T_a = 25^\circ\text{C}$ .

\*2: The power dissipation shown is for the IC package at  $T_a = 75^\circ\text{C}$ .

2. Pay attention to an electrostatic breakdown for pin 1.

3. Observe the following sequence of the supply power start-up:

- Turn-on sequence      First: Pin 2 on (7 V) power supply  
                                    Second: Pin 1 on (12 V) power supply
- Turn-off sequence      First: Pin 1 off (12 V) power supply  
                                    Second: Pin 2 off (7 V) power supply

## ■ Recommended Operating Range

Parameter	Symbol	Range	Unit
Supply voltage	$V_{CC1}$	10.8 to 13.2	V
	$V_{CC2}$	6.0 to 9.0	

### ■ Electrical Characteristics at $T_a = 25^\circ\text{C}$

Parameter	Symbol	Conditions	Min	Typ	Max	Unit
Circuit current 1	$I_{CC1}$	$V_{CC1} = 12\text{ V}$ , $V_{CC2} = 7\text{ V}$	16	20.5	25	mA
Circuit current 2	$I_{CC2}$	$V_{CC1} = 12\text{ V}$ , $V_{CC2} = 7\text{ V}$	—	0	1	mA
Circuit voltage 7	$V_{7-5}$	$V_{CC1} = 12\text{ V}$ , $V_{CC2} = 7\text{ V}$	2.8	3.0	3.2	V
Circuit voltage 8	$V_{8-5}$	$V_{CC1} = 12\text{ V}$ , $V_{CC2} = 7\text{ V}$	2.8	3.0	3.2	V
TILT output voltage 1	$E_{T1}$	$V_7 - V_8$ at $V_4 = 2.5\text{ V}$	-0.15	0	+0.15	V
TILT output voltage 2	$E_{T2}$	$V_7 - V_8$ at $V_4 = 5\text{ V}$	+2.3	+2.5	+2.7	V
TILT output voltage 3	$E_{T3}$	$V_7 - V_8$ at $V_4 = 0\text{ V}$	-2.7	-2.5	-2.3	V

#### • Design reference data

Note) The characteristics listed below are theoretical values based on the IC design and are not guaranteed.

Parameter	Symbol	Conditions	Min	Typ	Max	Unit
High-level TILT output fluctuation with supply voltage	$\Delta E_{T/V_{CCH}}$	$\Delta E$ when varying $V_{CC1} = 12\text{ V} \rightarrow 13.2\text{ V}$ and $V_{CC2} = 7\text{ V} \rightarrow 9\text{ V}$	-0.1	—	+0.1	V
Low-level TILT output fluctuation with supply voltage	$\Delta E_{T/V_{CCL}}$	$\Delta E$ when varying $V_{CC1} = 12\text{ V} \rightarrow 10.8\text{ V}$ and $V_{CC2} = 7\text{ V} \rightarrow 6\text{ V}$	-0.1	—	+0.1	V
TILT output fluctuation with temperature	$\Delta E_{T/T_a}$	$\Delta E$ when varying $T_a = 25^\circ\text{C} \rightarrow 70^\circ\text{C}$ and $T_a = +25^\circ\text{C} \rightarrow -20^\circ\text{C}$	-0.1	—	+0.1	V

### ■ Terminal Equivalent Circuits

Pin No.	Equivalent circuit	Description	DC voltage (V)
1		Supply voltage 12 V ( $V_{CC1}$ ): Supply voltage pin Apply DC 12 V.	12
2		Output block supply voltage 7 V ( $V_{CC2}$ ): TILT output supply voltage pin Apply DC 7 V via a protection resistor.	7
3	—	N.C.	—
4		TILT control input: TILT control input pin Apply DC 0 V to 5 V. (typ. = 2.5 V)	—

### ■ Terminal Equivalent Circuits (continued)

Pin No.	Equivalent circuit	Description	DC voltage (V)
5		GND2: Grounding pin of TILT output block	0
6	—	N.C.	—
7		TILT positive output: TILT positive output pin Outputs in the same polarity as pin 4.	1.7 to 4.2
8		TILT negative output: TILT negative output pin Outputs in the polarity opposite to pin 4.	1.7 to 4.2
9		GND1: 12 V-system grounding pin	0

### ■ Application Circuit Example

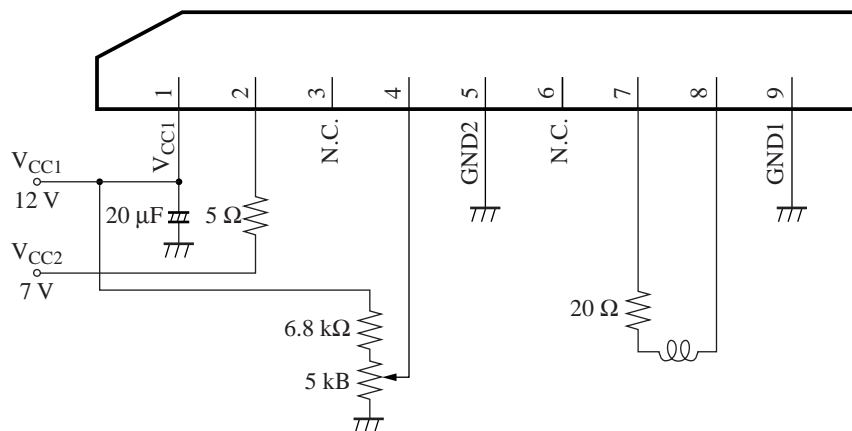

#### • Recommended application conditions

Parameter	Symbol	Range	Unit
TILT control input	V <sub>4-9</sub>	0 to 6	V
TILT positive output	I <sub>7</sub>	-150 to +150	mA
TILT negative output	I <sub>8</sub>	-150 to +150	mA
Peak current	I <sub>7P</sub>	-0.7 to +0.7	A
	I <sub>8P</sub>	-0.7 to +0.7	