

Current-Sensing Power MOSFETs

Kandarp Pandya

INTRODUCTION

Vishay Siliconix current-sensing power MOSFETs offer a simple means of incorporating a protection feature into an electronic control circuit and avoiding catastrophic failures resulting from overcurrent (overload) and/or short-circuit conditions. The device package is a modified D²PAK with five pins. The MOSFET termination retains the standard D²PAK footprint for a three-pin device. The additional two pins provide termination for a current-sense output and an internal Kelvin connection to the source. For current sensing, the MOSFET design employs a small number of the total number of MOSFET cells in a known ratio. The latter define the current-sense parameters. A typical control interface uses a simple circuit with an op-amp or a comparator. This approach offers the freedom of control-level setting and facilitates its incorporation into the main control system.

DEVICE DESCRIPTION AND PRINCIPLE OF OPERATION

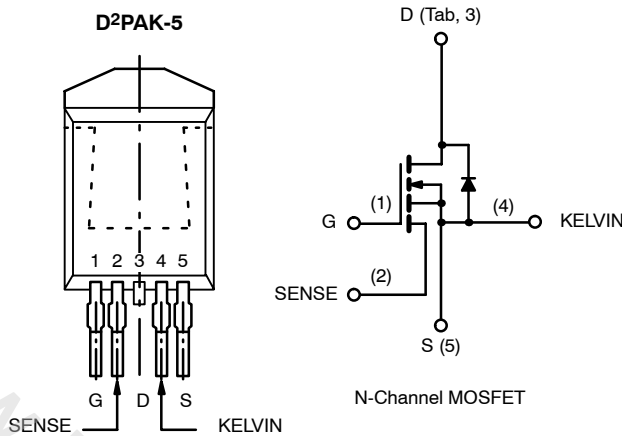

FIGURE 1. Package Information and Schematic Symbol

Package Information and Schematic Symbol, Figure 1, shows a partial reproduction of a datasheet for a current-sensing MOSFET, SUM50N03-13C. Gate, drain-stub/tab, and source (pins 1, 2, and 3) are in the same position as in a standard D²PAK (TO-263) MOSFET. However, pin-out modification is required to incorporate current-sense (pin 2) and Kelvin-to-source (pin 4)

between gate and drain-stub and between drain-stub and source, respectively. See Application Note 826, *Recommended Minimum Pad Patterns With Outline Access for Vishay Siliconix MOSFETs* (<http://www.vishay.com/doc?72286>), for the recommended PCB layout dimensional details of the pad pattern. Modified-part library symbols for schematic symbol and PCB layout are available on the “Protel” (PCB design software) platform. For soft copy, please contact Vishay Siliconix in Santa Clara, Calif., in the United States, by phoning 1-408-567-8927.

The Principle Behind the Current-Sensing Feature

The most efficient way to sense the drain-source current is to use the ratio-metric measurement. In a power MOSFET, it is possible to implement this method easily.

The cell density, a favored term within the power MOSFET industry, conveys that the power MOSFET structure consists of many cells connected in parallel. In principle, these cells constitute a resistive path for drain-source current. Electrically, these cells are parallel connected resistors, $r_{DS(on)}$ s. Each cell - being identical in structure and electrical characteristics - shares the current equally when the device is on. This property enables design of a MOSFET with a current-sensing feature.

Dividing the MOSFET cells in a known ratio creates two paths that share the drain-source current. The path with the smaller number of cells constitutes the sense current, which is much smaller than the current conducting through the rest of the cells. A very simple, low-power, external circuit can measure this current. Multiplying this value with the cell ratio gives the total drain-source current.

The classic Kelvin termination for the return of sense current to the main source connection insures the measurement accuracy. This terminal not only eliminates the ground loop, but also minimizes the imbalance of internal structures with two current paths.

The Current-Sensing Parameters, Table 1, and the Current-Sense Die Characteristics and Schematic, Figure 2, help to demonstrate the current-sensing operation and circuit implementation.

TABLE 1: Current Sense Characteristics

Current Sensing Ratio	r	$I_D = 1 \text{ A}, V_{GSS} = 10 \text{ V}, R_{SENSE} = 1.1 \Omega$	420	520	620	
Mirror Active Resistance	$r_{m(on)}$	$V_{GS} = 10 \text{ V}, I_D = 10 \text{ mA}$		3.5		Ω

TYPICAL CHARACTERISTICS (25 °C UNLESS NOTED)

SENSE DIE

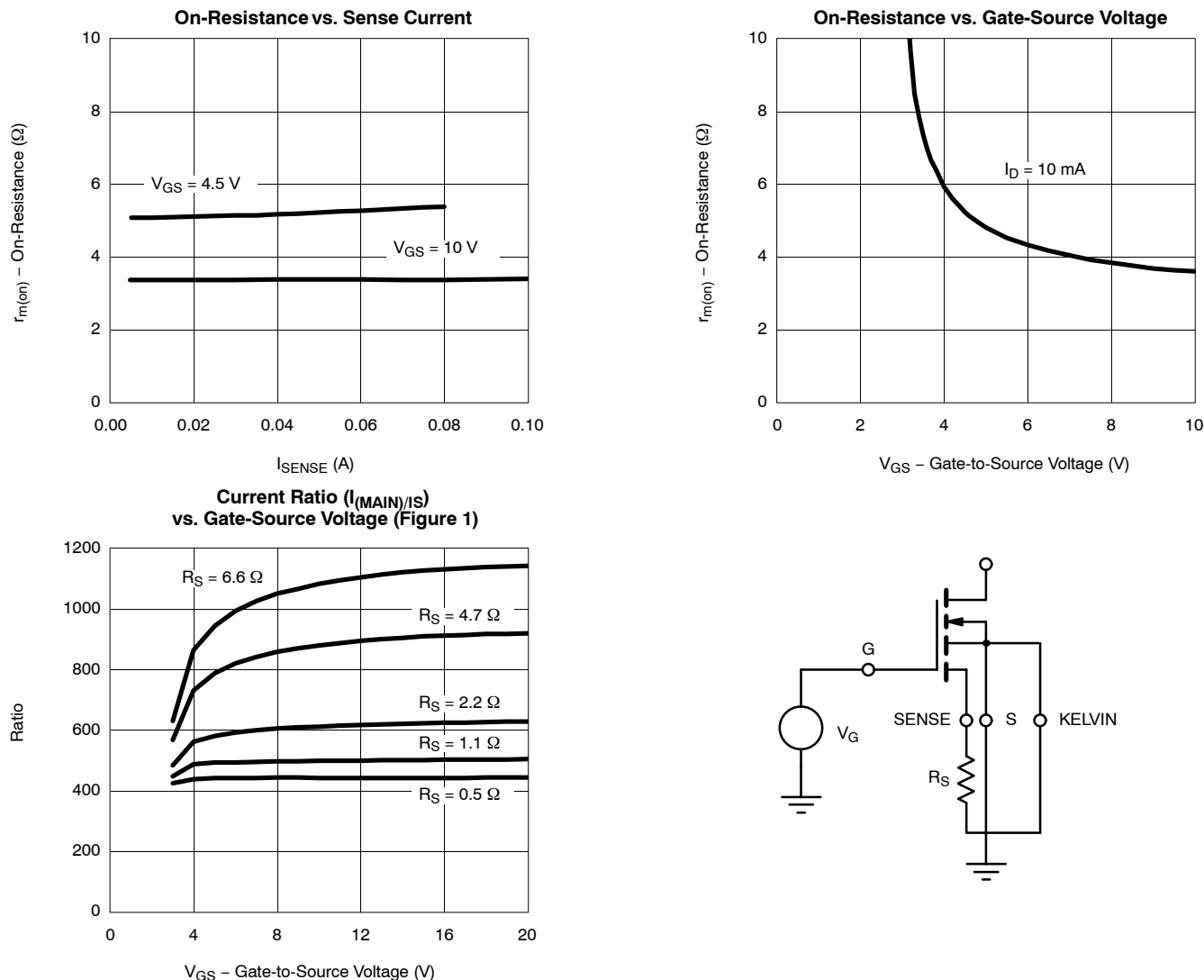

FIGURE 2. Current-Sensing Die Characteristics and Schematic

Definition of Current-Sensing Parameters

The current-sense ratio, *r*, is the quotient of the number of cells terminated on the sense terminal to the total number of cells on the MOSFET die.

To derive the value of *r* using the above definition requires detailed die design. However, the quotient of drain current to the sense current provides the same value because these current values are the sum of cell current in each path.

Mathematically:

$$r = I_D / I_{SENSE}$$

I_D is drain current

I_{SENSE} is the current flowing out of the sense terminal and into the sense resistor, *R_{SENSE}*

Mirror active resistance, *r_{m(on)}*, is the resistance of parallel connected cells used in the sense chain when the device is on. Being *r_{DS(on)}* as in any other MOSFET, the value depends on the gate drive, drain current, and junction temperature. Accordingly, *r_{m(on)}* is defined at given values of *V_{GS}*, *I_{DRAIN}*, and *T_J* junction.

By definition, for the sense die, refer to Figure 2. Mirror active resistance *r_{m(on)}* is specified at the gate-source voltages, *V_{GS}* at 4.5 V and 10 V, corresponding drain-source current *I_{SENSE}* up to 0.1 A, and junction temperature *T_J* at 25 °C. The temperature coefficient of *r_{m(on)}* is the same as that of *r_{DS(on)}*. Refer to the on-resistance vs. junction temperature curve in Figure 3.

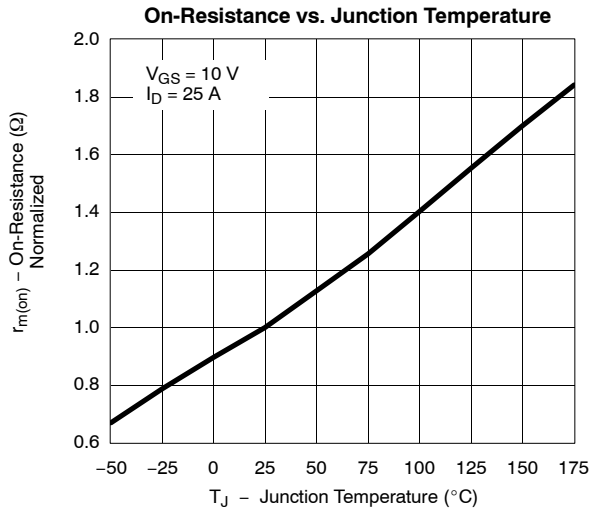
FIGURE 3. Normalized $r_{m(on)}$ for the Sense Die

DESIGN EQUATIONS

The following three equations enable circuit design and analysis.

$$I_{SENSE} = x I_D / r$$

$$V_{DS} = I_{SENSE} \times [r_{m(on)} + R_{SENSE}] \text{ or}$$

$$V_{DS} = I_D \times r_{DS(on)} / (r_{m(on)} + R_{SENSE})$$

$$V_{SENSE} = I_{SENSE} \times R_{SENSE} \text{ or}$$

$$V_{SENSE} = V_{DS} \times R_{SENSE} / (r_{m(on)} + R_{SENSE})$$

Where	I_{SENSE}	Current flowing out of sense terminal
	r	Current-sensing ratio
	I_D	Drain-source current
	V_{DS}	Drain-source voltage
	$r_{m(on)}$	Mirror active resistance
	R_{SENSE}	External current-sense resistor

Application Aspects and Design Examples

The current-sense ratio r , even though fixed by design, is dependent on manufacturing process variations. Furthermore, mirror active resistance $r_{m(on)}$ depends on circuit parameters V_{GS} and I_D and junction temperature T_J . As a result, a practical design can realize an accuracy of 15% — 20% for current sensing. Accordingly, the current-sensing MOSFET is most suitable for supervisory functions such as overcurrent and/or short-circuit protection.

Three keys to a successful design are to:

1. have an adequate margin between the normal operating-current value and the trip-current value;

2. use a minimum value of the I_{SENSE} signal at the maximum value of I_D ; and
3. use a fast comparator with hysteresis to control and protect the MOSFET.

Typical schematic configurations for implementing the current sense are shown in Figure 4 and Figure 5.

The Virtual Earth Sensing Scheme, Figure 4, is suitable for applications aiming at higher noise immunity and speed. This approach also improves measurement accuracy by eliminating the sense resistor. However, a dual power supply and inverted (negative) output signal are the price designers pay for deriving these benefits.

The Resistor Sensing Scheme shown in Figure 5 is a quite simple and economical approach. The accuracy of current measurement is affected by the introduction of an external sense resistor R_S . However, the latter aids in lowering the temperature sensitivity of the current-sense signal.

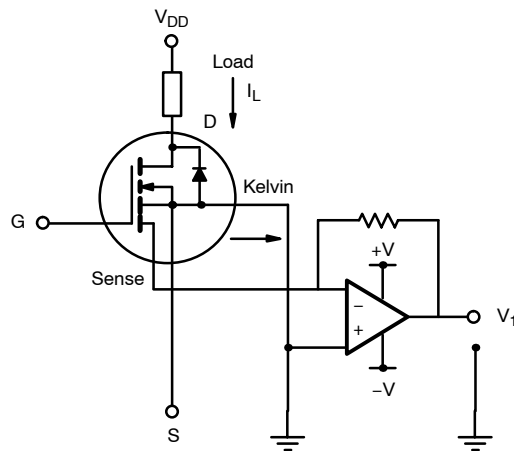
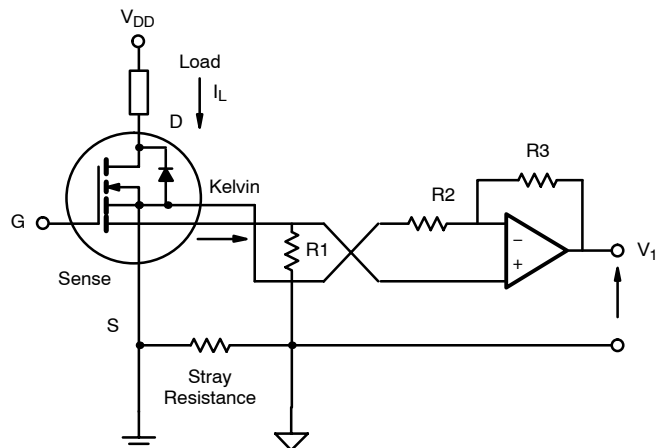

FIGURE 4. Virtual Earth Sensing Scheme

FIGURE 5. Resistor Sensing Scheme

TABLE 2: Current Product Range

Part #	Channel Type	V _{DS} (VDC)	r _{DS} (Ω)	I _{DS} (A)	P _D (W)	Package
Si6862DQ	N	20	0.026/4.5 V	6.6	1.8	TSSOP-8*
Si4730EY	N	30	0.015/10 V	11.7	3.6	SO-8*
SUM50N03-13LC	N	30	0.013/10 V	50	83	D ² PAK-5
SUM60N08-07C	N	75	0.007/10 V	60	300	

Recommended minimum pads for current-sensing MOSFETs in TSSOP-8 and SOIC-8 packages see application note AN826 (<http://www.vishay.com/doc?72286>).

CONCLUSION

Vishay Siliconix current-sensing power MOSFETs enable implementation of a simple solution for incorporating supervisory protection features such as overcurrent and/or short circuit. This approach offers the freedom and flexibility of control-circuit design, though the accuracy of measurement is not suitable for current-control applications. Virtually any power MOSFET from the Vishay Siliconix product range can be supplied with a current-sensing feature.