

AN6401NFA

Pager Direct Conversion FSK Demodulator Base-Band IC

Overview

The AN6401NFA is a base-band IC supporting direct conversion FSK demodulation for pagers.

Features

- Low current consumption : V_{CC1} current consumption $I_{CC1} = 510 \mu A$ ($V_{CC1} = 2.0V$), V_{CC2} current consumption $I_{CC2} = 330 \mu A$ ($V_{CC2} = 1.4V$)
- Battery saving function : current consumption is less than $1 \mu A$ at BS
- Incorporating two regulator circuits (REG1 and REG2 : 1.05 V).

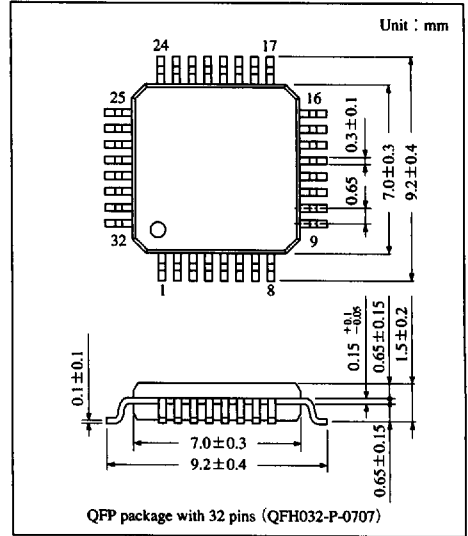

Block Diagram

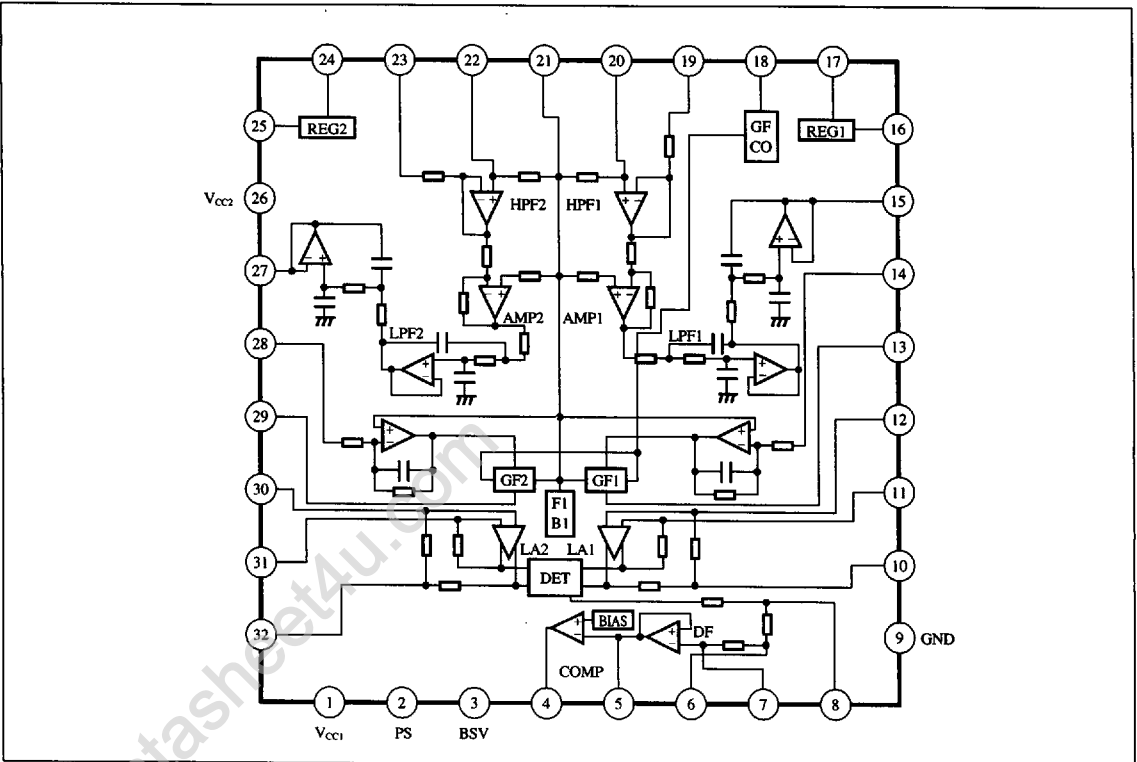

6932852 0013201 2T4

■ Absolute Maximum Ratings (Ta=25°C)

Parameter	Symbol	Rating	Unit
Supply voltage	V _{CC}	4	V
Supply current	I _{CC}	5	mA
Power dissipation (Ta = 75°C)	P _D	20 (Ta = 75°C)	mW
Operating ambient temperature	T _{opr}	-20 to +70	°C
Storage temperature	T _{stg}	-55 to +125	°C

■ Operating Supply Voltage Range

Parameter	Symbol	Range
Operating supply voltage range	V _{CC1}	1.8 to 4V
	V _{CC2}	0.9 to 1.6V

■ Electrical Characteristics (V_{CC1}=2.0V, V_{CC2}=1.4V, Ta=25±2°C)

Parameter	Symbol	Condition	min	typ	max	Unit
V _{CC1} current consumption (operational)	I ₁		385	510	635	μA
V _{CC1} current consumption (at BSV)	I _{1(BS)}		—	0	1.0	μA
V _{CC2} current consumption (operational)	I ₂		250	330	410	μA
V _{CC2} current consumption (at PS)	I _{2(PS)}		—	0	1.0	μA
REG1 output voltage	V _{REG1}		1.00	1.05	1.10	V
REG2 output voltage	V _{REG2}		1.00	1.05	1.10	V
Channel filter F characteristics F1b	V _{F1b}	V ₁₁ = -40dBs, f ₁₁ = 4kHz	-33.5	-31.0	-28.5	dBs
Channel filter F characteristics F2b	V _{F2b}	V ₁₂ = -40dBs, f ₁₂ = 4kHz	-33.5	-31.0	-28.5	dBs
Channel filter F characteristics F1c	V _{F1c}	V ₁₁ = -40dBs, f ₁₁ = 25kHz	—	—	-73	dBs
Channel filter F characteristics F2c	V _{F2c}	V ₁₂ = -40dBs, f ₁₂ = 25kHz	—	—	-73	dBs
Data demodulator characteristics (High)	V _{4H}	V ₁₁ = V ₁₂ = -40dBs f ₁₁ = f ₁₂ = 4kHz θ ₁₁ = θ ₁₂ - π/2	1.8	—	—	V
Data demodulator characteristics (Low)	V _{4L}	V ₁₁ = V ₁₂ = -40dBs f ₁₁ = f ₁₂ = 4kHz θ ₁₁ = θ ₁₂ + π/2	—	—	0.2	V

Note) 0dBs = 775mVrms

■ Electrical Characteristics (design values for reference) (V_{CC1}=2.0V, V_{CC2}=1.4V, Ta=25±2°C)

Parameter	Symbol	Condition	min	typ	max	Unit
Channel filter F characteristics F1a	V _{F1a}	V ₁₁ = -40dBs, F ₁₁ = 1kHz	—	-30.5	—	dBs
Channel filter F characteristics F2a	V _{F2a}	V ₁₂ = -40dBs, F ₁₂ = 1kHz	—	-30.5	—	dBs
Channel filter F characteristics F1d	V _{F1d}	V ₁₁ = -40dBs, F ₁₁ = 50kHz	—	—	-73	dBs
Channel filter F characteristics F2d	V _{F2d}	V ₁₂ = -40dBs, F ₁₂ = 50kHz	—	—	-73	dBs
Data duty characteristics	V _D	$VD = \frac{V_{SH} + V_{SL}}{2} - V_{SC}$ V ₁₃ = V ₁₄ = -40dBs f ₁₃ = f ₁₄ = 4kHz V _{SH} : θ ₁₃ = θ ₁₄ - π/2 V _{SL} : θ ₁₃ = θ ₁₄ + π/2 V _{SC} : V ₄ with H and L exchanged	—	0	—	mV

6932852 0013202 130

■ Pin Descriptions

Pin No.	Symbol	Description	Pin No.	Symbol	Description
1	V _{CC1}	Supply voltage (1)	17	RG1	Regulator (1) voltage detection
2	PS	Power saving signal input	18	GFC	Gyrator filter control
3	BSV	Battery saving signal input	19	H1O	Ch1 2nd HPF output
4	NRZ	Demodulator data output	20	H1I	Ch1 2nd HPF input
5	DFO	Data filter output	21	FBI	Filter bias output
6	DF2	Data filter input (2)	22	H2I	Ch2 2nd HPF input
7	DF3	Data filter input (3)	23	H2O	Ch2 2nd HPF output
8	DF1	Data filter input (1)	24	RG2	Regulator (2) voltage detection
9	GND	Ground	25	R2C	Regulator (2) voltage control
10	L1F	Ch1 limiter amp. feedback	26	V _{CC2}	Supply voltage (2)
11	L1R	Ch1 limiter amp. reference	27	F2O	Ch2 4th LPF output
12	L1I	Ch1 limiter amp. input	28	F2I	Ch2 1st LPF input
13	G1O	Ch1 gyrator filter output	29	G2O	Gyrator filter output
14	F1I	Ch1 1st LPF input	30	L2I	Ch2 limiter amp. input
15	F1O	Ch1 4th LPF output	31	L2R	Ch2 limiter amp. reference
16	R1C	Regulator (1) voltage control	32	L2F	Ch2 limiter amp. feedback

■ Application Circuit

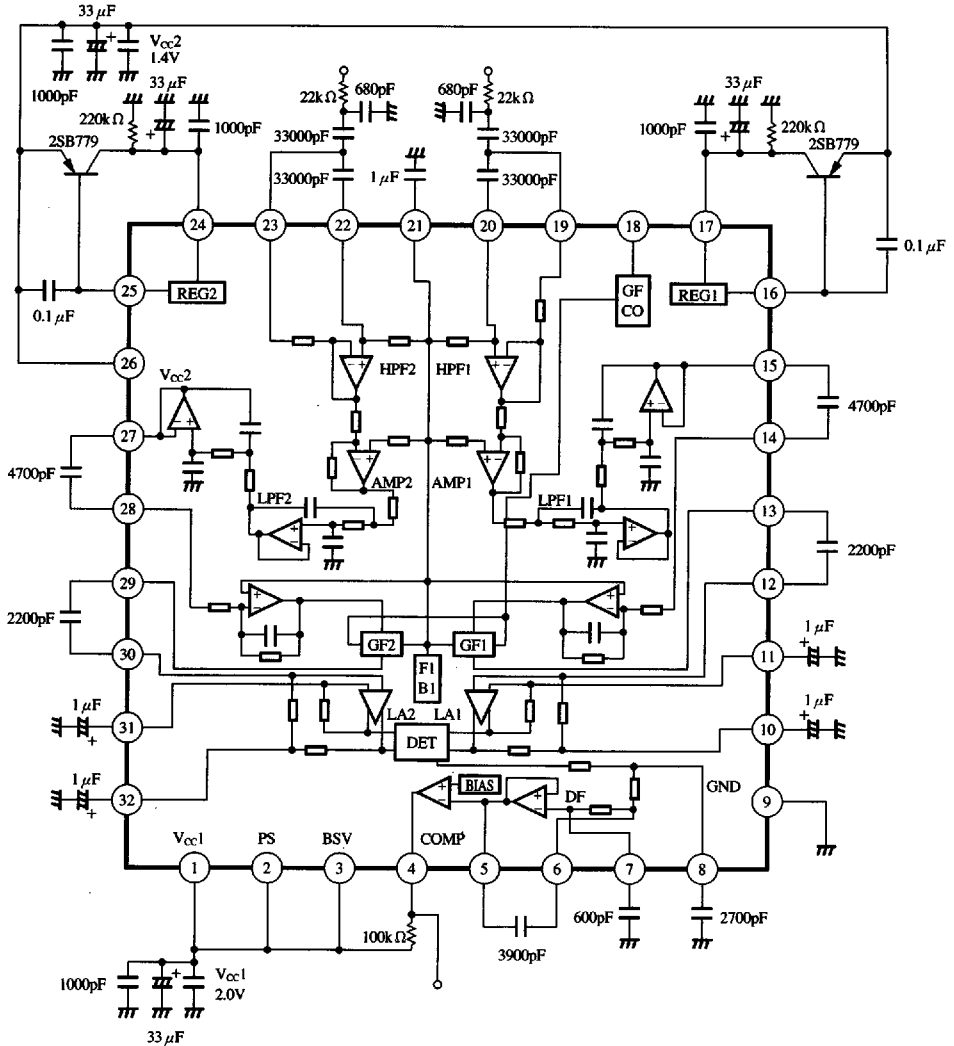

6932852 0013204 T03

Panasonic