

AN6608, AN6609N, AN6609NS

DC Motor Forward/Reverse Dual Speed Electronic Governors

■ Overview

The AN6608, the AN6609N and the AN6609NS are the electronic governors which incorporate the forward/reverse rotation and double speed controls of the DC motors used for radio/cassette tape recorder, and the functions such as fast forward, rewind, brake, and pause. They are also available for controlling the video tape deck mechanisms such as the VCRs and DATs. The AN6608, the AN6609N and the AN6609NS are identical with each other except the operating logic by 3-bit input.

■ Features

- Operating supply voltage range ; $V_{CC} = 8V$ to $16V$
- Stable reference voltage ($1.27V$) and easy speed adjustment
- Large starting torque and maximum control torque
- Built-in power transistor
- Forward/reverse constant speed and double speed controls, and fast forward, brake, and pause functions available by 3-bit input

■ Applications

VCRs, cassette decks, radio/cassette tape recorders, car cassette tape players, tape loading DC motor control such as DATs.

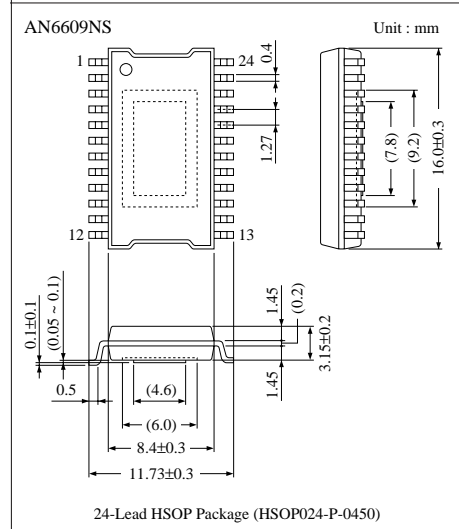
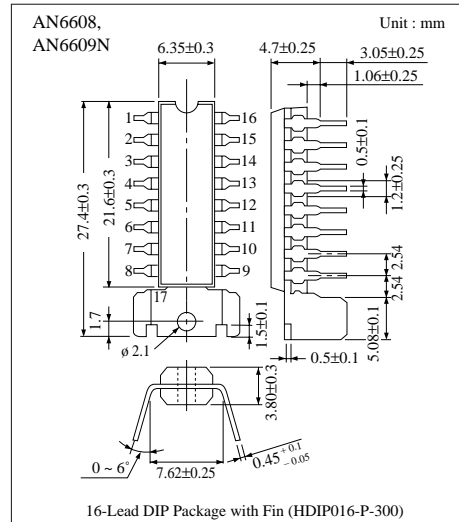

■ Block Diagram

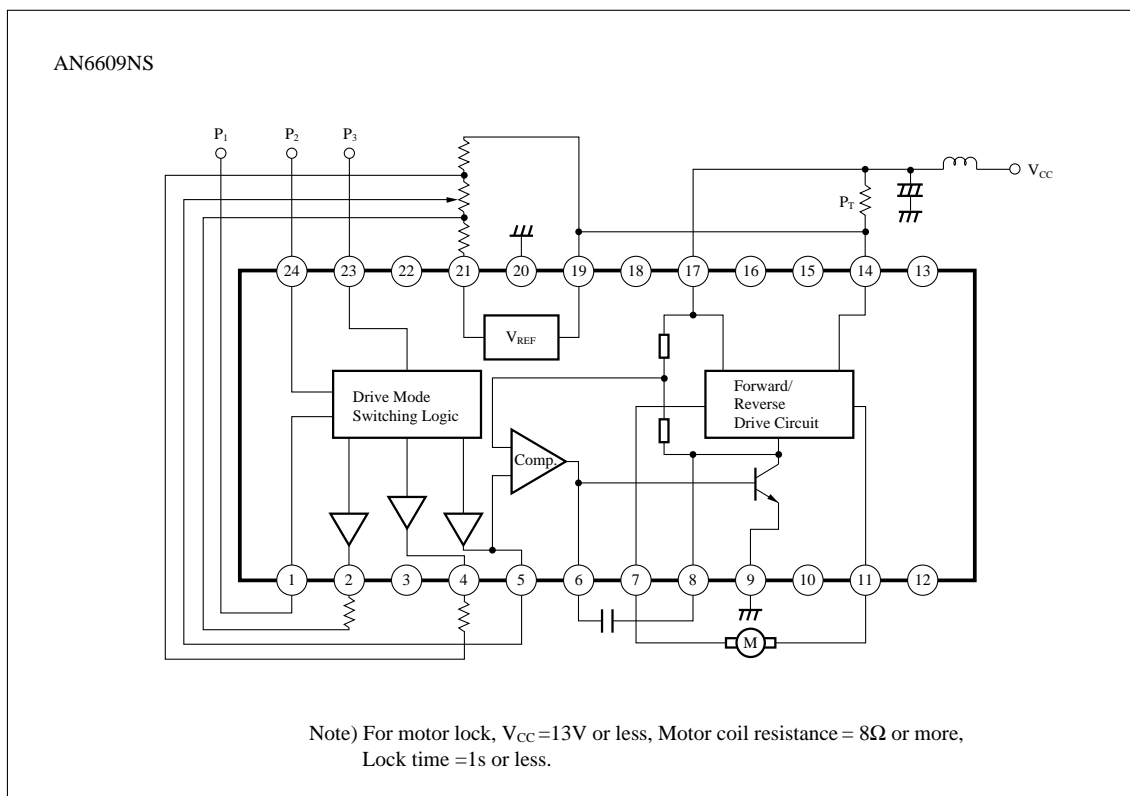
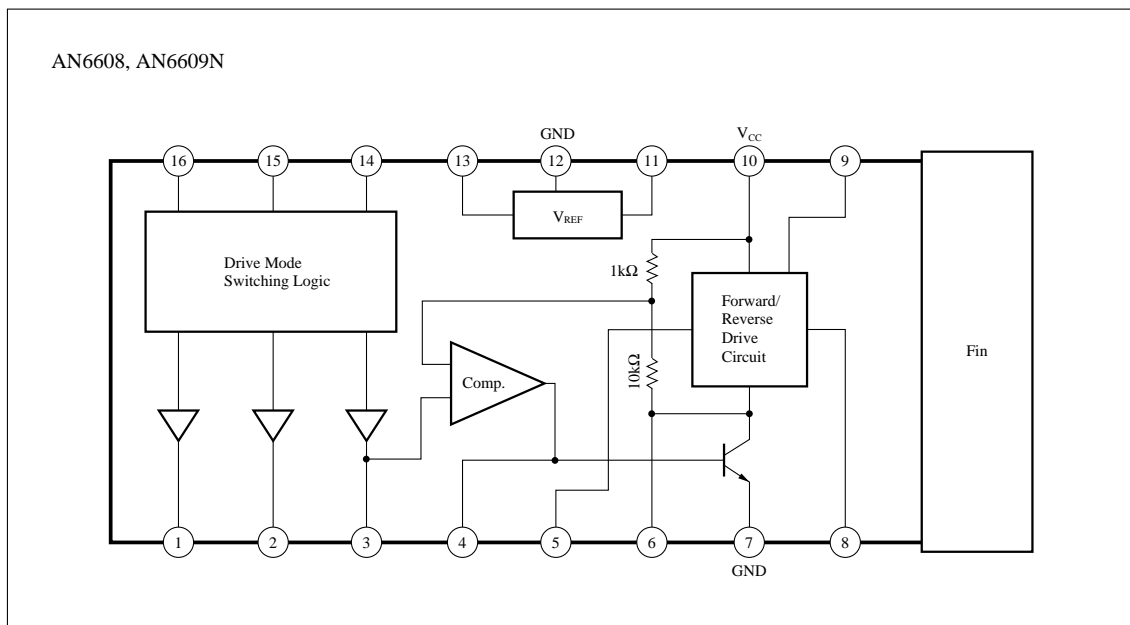

■ Absolute Maximum Ratings (Ta= 25°C)

Parameter	Symbol	Rating	Unit
Supply Voltage	V _{CC}	18	V
Supply Current	I _{CC}	1800 Note 1)	mA
Power Dissipation	P _D	AN6608, AN6609N	2 Note 2)
		AN6609NS	2.08 Note 3)
Operating Ambient Temperature	T _{opr}	-20 ~ + 70	°C
Storage Temperature	T _{stg}	-50 ~ +150	°C

Note 1) t ≤ 200ms

Note 2) Mounting on PCB (20mm × 20mm of copperfoil is used for heat sink)

Note 3) Glass epoxy PCB (50mm × 50mm × 1.2mm)

■ Recommended Operating Range (Ta = 25°C)

Parameter	Symbol	Range
Operating Supply Voltage Range	V _{CC}	8V ~ 16V

■ Electrical Characteristics (Ta = 25°C)

Parameter	Symbol	Condition	min.	typ.	max.	Unit
Bias Current at No Load	I _{bias}	V _{CC} =12V	—	7	15	mA
Reference Voltage	V _{ref}	V _{CC} =12V	1.15	1.27	1.4	V
Rated Load Start Voltage	V _{CC(s)}	Supply voltage with which a motor starts rotating	6.5	—	—	V
Rated r.p.m.	N _L	V _{CC} =12V, N=1600rpm	-8.75	—	8.75	%
r.p.m. Characteristics on Load Change	DN _L	V _{CC} =8V, I _L =55mA ~ 120mA	-100	—	100	rpm
r.p.m. Characteristics on Voltage Change	DN _V	V _{CC} =8V ~ 16V, N=1600rpm	-22	0	22	rpm
Double Speed Forward/Reverse r.p.m. Difference	DN _{Logi}	V _{CC} =12V, N=3200rpm	-3	0	3	%
Output Saturation Voltage 1	V _{sat(1)}	V _{CC} =8V, I _O =1A	—	—	2	V
Output Saturation Voltage 2	V _{sat(2)}	V _{CC} =8V, I _O =1A	—	—	1.5	V
r.p.m. Characteristics on Temperature Change	DN _A	V _{CC} =12V, Ta= -10°C ~ + 60°C	—	100	—	rpm/°C
r.p.m. Drift Characteristics by Time	DN _T	V _{CC} =12V, t=15s ~ 10ms	—	0.4	—	%

■ Application Circuit

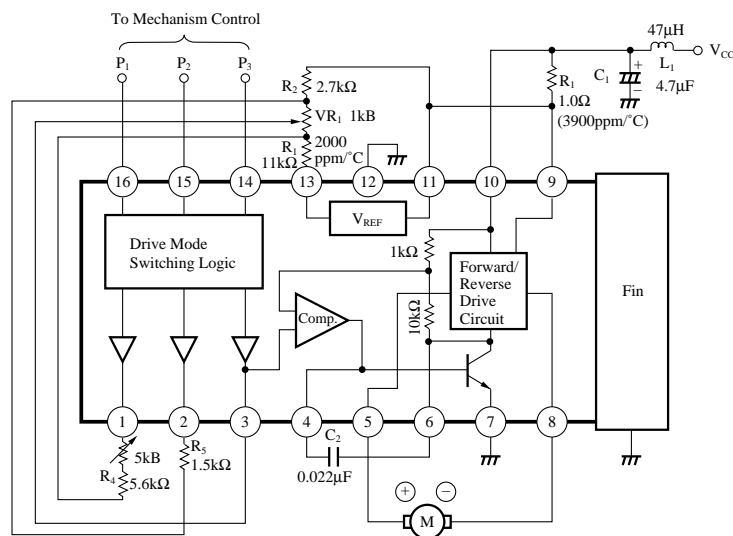

AN6608
AN6609N



■ Pin Descriptions

Pin No.		Pin Name	Typ. Waveform	Description	Input Impedance	Equivalent Circuit
AN6608 AN6609N	AN6609NS					
1	2	Double Speed Setting	—	Pin to set the double speed r.p.m.	T_{rC}	
2	4	FF, REW Speed Setting	—	Pin to set the FF/REW r.p.m.	T_{rC}	
3	5	Speed Control	—	Speed control pin A fixed resistor will do if fine adjustment is unnecessary.	T_{rE}	
4	6	Phase Adjustment	—	Phase adjustment pin for oscillation prevention	T_{rE}	
5	7	Motor Connection ⊕		Pin to connect the motor ⊕ side	T_{rE} T_{rC}	
6	8	Phase Adjustment		Phase adjustment pin for oscillation prevention	T_{rC}	
7	9	GND	—	GND pin for the power section inside the IC	T_{rE}	
8	11	Motor Connection ⊖		Pin to connect the motor ⊖ side	T_{rE} T_{rC}	
9	14	Load Characteristics Setting		Pin to set the load characteristics (S-T curve) of the motor	T_{rC}	

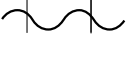
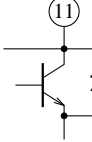
■ Pin Descriptions (Cont.)

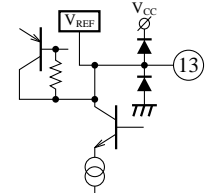
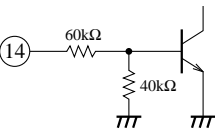
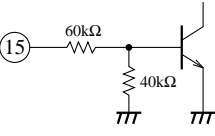
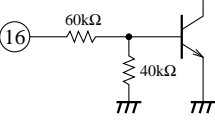
Pin No.		Pin Name	Typ. waveform	Description	Input Impedance	Equivalent Circuit
AN6608 AN6609N	AN6609NS					
10	17	V _{CC}	—	IC power pin	—	—
11	19	Connect to Pin9 . Ref. Voltage ⊕ Output		Reference voltage⊕ output pin when connecting to the pin9.	T _{IC}	
12	20	GND	—	GND pin for the IC bias section	—	
13	21	Ref. Voltage ⊖ Output		Reference voltage⊖ output pin	T _{IC}	
14	23	Logic Input P ₃	—	Logic input pin P ₃ to set the motor control state	60kΩ	
15	24	Logic Input P ₂	—	Logic input pin P ₂ to set the motor control state	60kΩ	
16	1	Logic Input P ₁	—	Logic input pin P ₁ to set the motor control state	60kΩ	

■ Supplementary Explanation

• Operating Logic

Input Pins			Output Pins (AN6608)					Output Pins (AN6609N)				
14	15	16	5	8	1	2	Operating Mode	5	8	1	2	Operating Mode
H	H	H	H	L	OFF	ON	FF	—	—	OFF	OFF	Pause
L	H	H	L	H	OFF	ON	REW	H	L	ON	OFF	Double speed
H	L	H	H	L	OFF	OFF	Constant speed	H	L	OFF	OFF	Constant speed
H	H	L	H	H	OFF	OFF	Brake	H	H	OFF	OFF	Brake
L	L	H	H	L	ON	OFF	Double speed	H	L	OFF	ON	FF
L	H	L	L	H	ON	OFF	Reverse double speed	L	H	ON	OFF	Reverse double speed
H	L	L	L	H	OFF	OFF	Reverse constant speed	L	H	OFF	OFF	Reverse constant speed
L	L	L	—	—	OFF	OFF	Pause	—	—	OFF	OFF	Pause

* Input level H : 3V or more, Input level L : 0.7V or less
 For the AN6609NS, the above pin numbers must be replaced.

• Characteristics Curve

AN6608, AN6609N

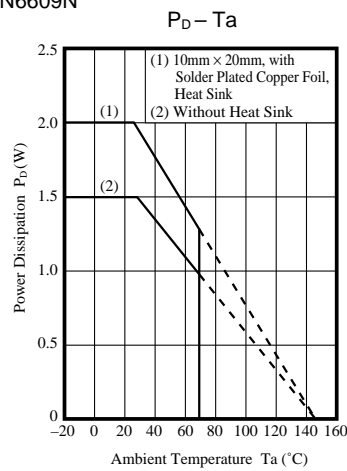

AN6609NS

