

# AN6912, AN6912S

## Quadruple Comparators

### Outline

The AN6912 and the AN6912S are quadruple (voltage) comparators with wide range of operating supply voltages.

### Features

- Wide range of supply voltage
  - Single supply : 2~36V
  - Dual supply :  $\pm 1 \sim \pm 18V$
- Low circuit current : 0.8mA typ.
- Wide range of common-mode input voltage
  - 0V ~  $V_{CC} - 1.5V$  (single supply)
- Open collector output

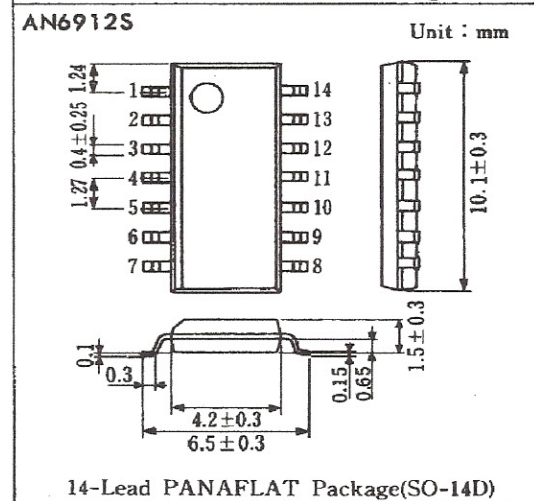
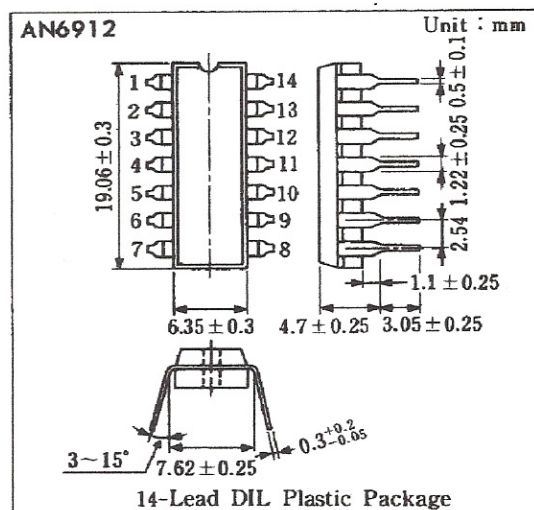

### Schematic Diagram

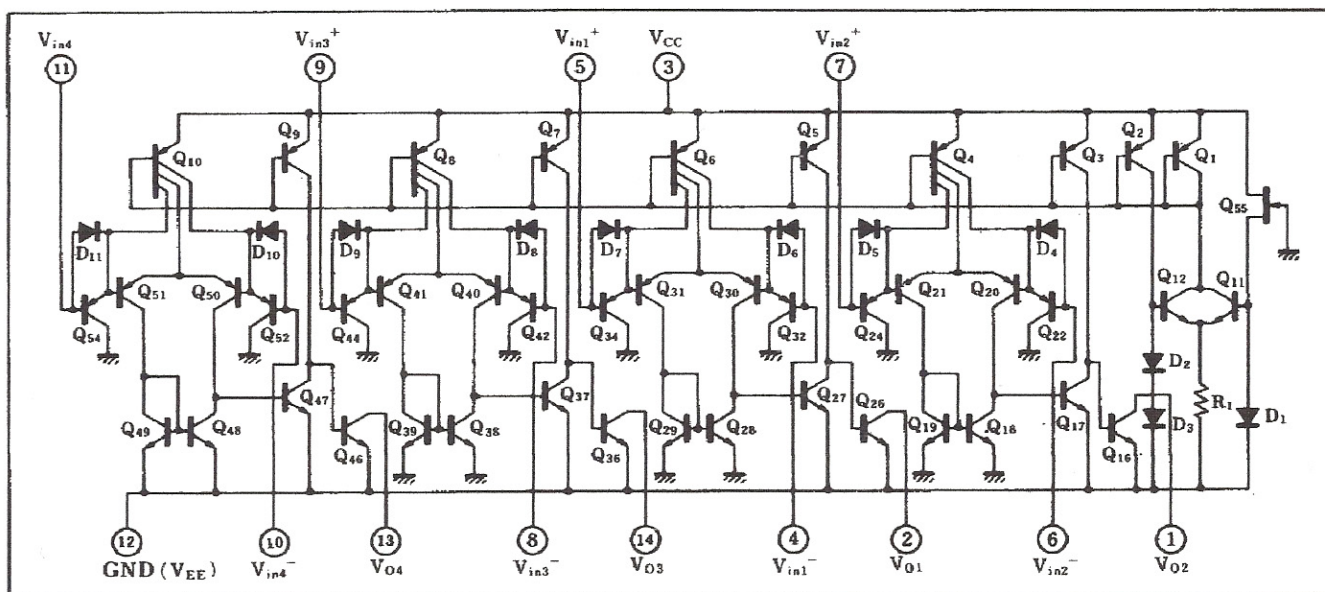

■ Absolute Maximum Ratings (Ta=25°C)

Item	Symbol	Rating	Unit	
Voltage	Supply Voltage	V <sub>CC</sub>	36	V
	Common-Mode Input Voltage	V <sub>ICM</sub>	-0.3 ~ +36	V
	Differential Input Voltage	V <sub>ID</sub>	36	V
Power Dissipation	AN6912	P <sub>D</sub>	570	mW
	AN6912S		380	
Operating Ambient Temperature	T <sub>opr</sub>	-20 ~ +75	°C	
Storage Temperature	AN6912	T <sub>stg</sub>	-55 ~ +150	°C
	AN6912S		-55 ~ +125	

■ Electrical Characteristics (V<sub>CC</sub>=5V, Ta=25±2°C)

Item	Symbol	Test Circuit	Condition	min.	typ.	max.	Unit
Input Offset Voltage	V <sub>I(offset)</sub>	1			2	5	mV
Input Offset Current	I <sub>IO</sub>	1				50	nA
Input Bias Current	I <sub>Bias</sub>	1				250	nA
Voltage Gain	G <sub>V</sub>	1	R <sub>L</sub> =15kΩ		200		V/mV
Common-Mode Input Voltage Range	V <sub>CM</sub>	2		0		V <sub>CC</sub> -1.5	V
Supply Current	I <sub>CC</sub>	3	R <sub>L</sub> =∞		0.8	2	mA
Response Time	t <sub>r</sub>	4	R <sub>L</sub> =5.1kΩ, V <sub>RL</sub> =5V		1.3		μs
Output Sink Current	I <sub>SINK</sub>	5	R <sub>REF</sub> =0V, V <sub>I</sub> =1V, V <sub>O</sub> ≤1.5V	6			mA
Low-Level Output Voltage	V <sub>OL</sub>	6	V <sub>REF</sub> =0V, V <sub>I</sub> =1V, I <sub>(SINK)</sub> =3mA		0.2	0.4	V
Output Terminal Leakage Current	I <sub>C(Leak)</sub>	7	V <sub>I</sub> =0V, V <sub>REF</sub> =1V, V <sub>O</sub> =5V		0.1		nA

Test Circuit 1 (V<sub>I(offset)</sub>, I<sub>IO</sub>, I<sub>Bias</sub>, G<sub>V</sub>)

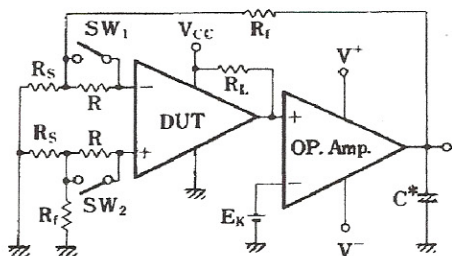

\*Capacitors for the prevention of oscillation and bipolar should be used (NP).

Test Circuit 3 (I<sub>CC</sub>)

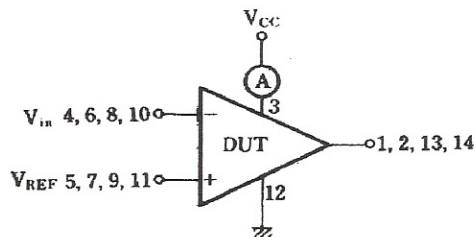

Test Circuit 2 (V<sub>CM</sub>)

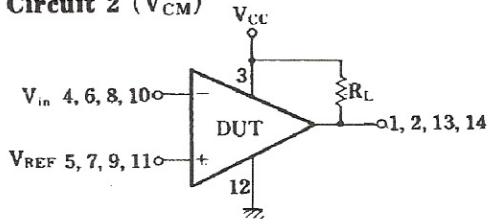

Test Circuit 4 (t<sub>r</sub>)

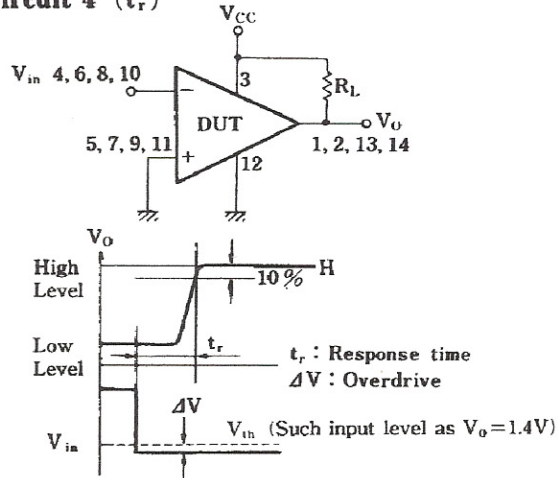



### Test Circuit 5 ( $I_{SINK}$ )

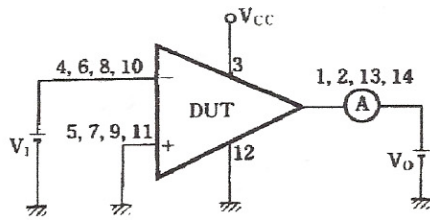

### Test Circuit 6 ( $V_{OL}$ )

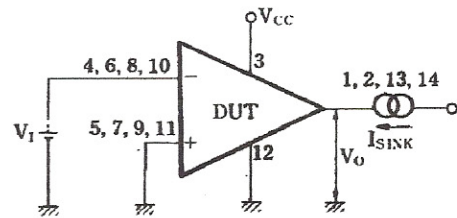

### Test Circuit 7 ( $I_{O(Leak)}$ )

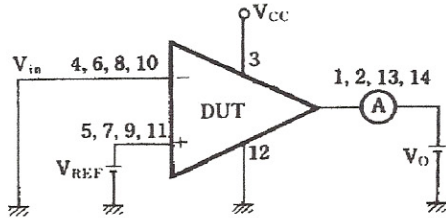

### Application Circuit

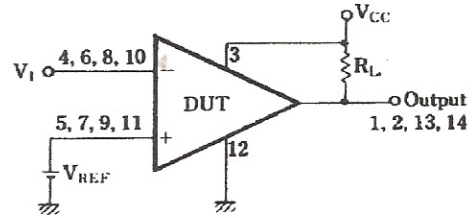

### $I_{CC} - V_{CC}$

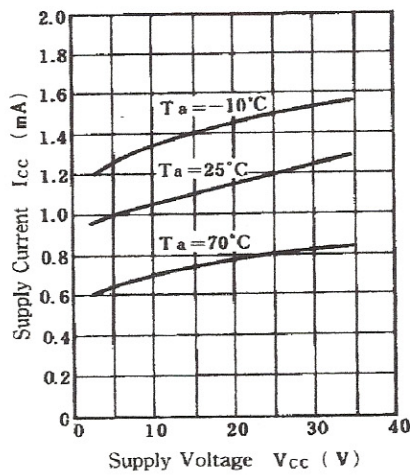

### $I_{Bias} - V_{CC}$

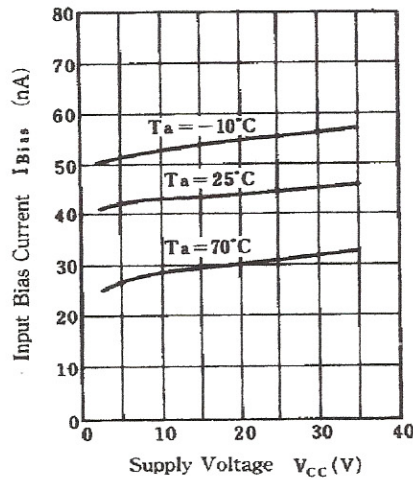

### $V_{OL} - I_{SINK}$

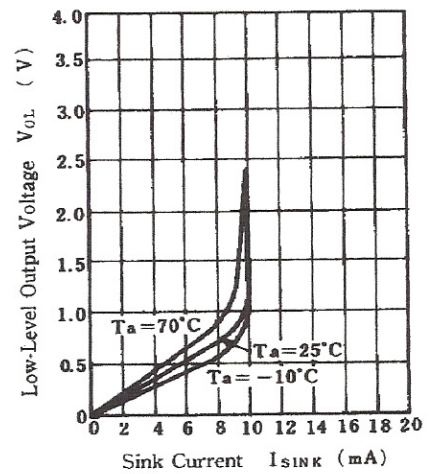

### Transfer Characteristics (1)

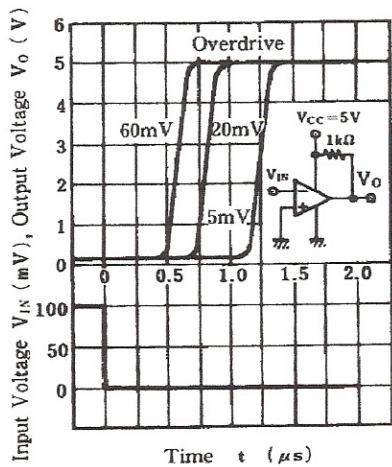

### Transfer Characteristics (2)

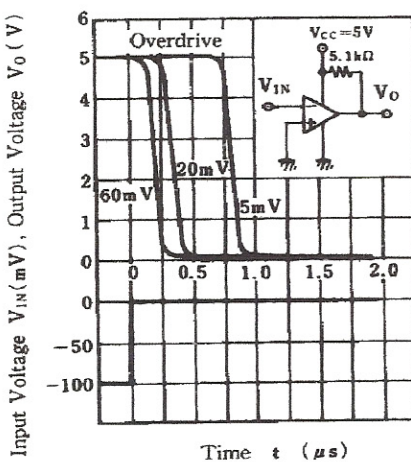

■ Block Diagram

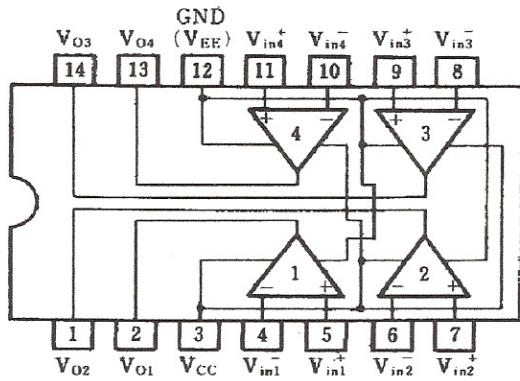

■ Pin

Pin No.	Pin Name
1	Ch. 2 Output
2	Ch. 1 Output
3	$V_{CC}$
4	Ch. 1 Inverting Input
5	Ch. 1 Non Inverting Input
6	Ch. 2 Inverting Input
7	Ch. 2 Non Inverting Input
8	Ch. 3 Inverting Input
9	Ch. 3 Non Inverting Input
10	Ch. 4 Inverting Input
11	Ch. 4 Non Inverting Input
12	GND ( $V_{EE}$ )
13	Ch. 4 Output
14	Ch. 3 Output