

AN7177

Dual BTL 20W Audio Power Amplifier

■ Description

The AN7177 is a monolithic integrated circuit designed for Dual BTL audio power amplifier suitable for Hi-Fi and car stereo.

■ Features

- High output power (20W x 2)
- Incorporating stand-by circuits
- Low shock noise from power ON/OFF switching
- Fewer external components
- Incorporates protection circuits
- Highly stable operation

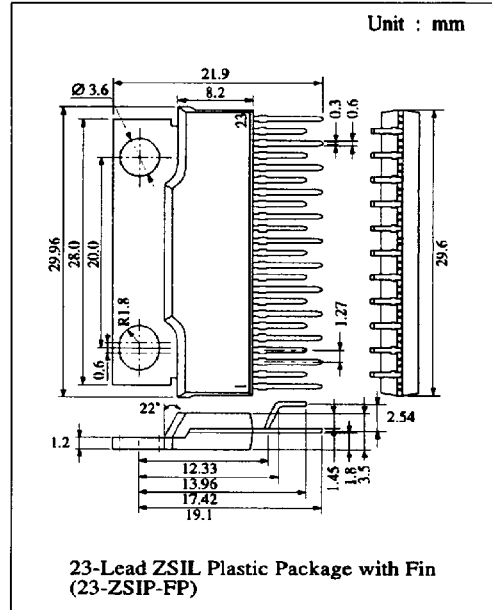

■ Block Diagram

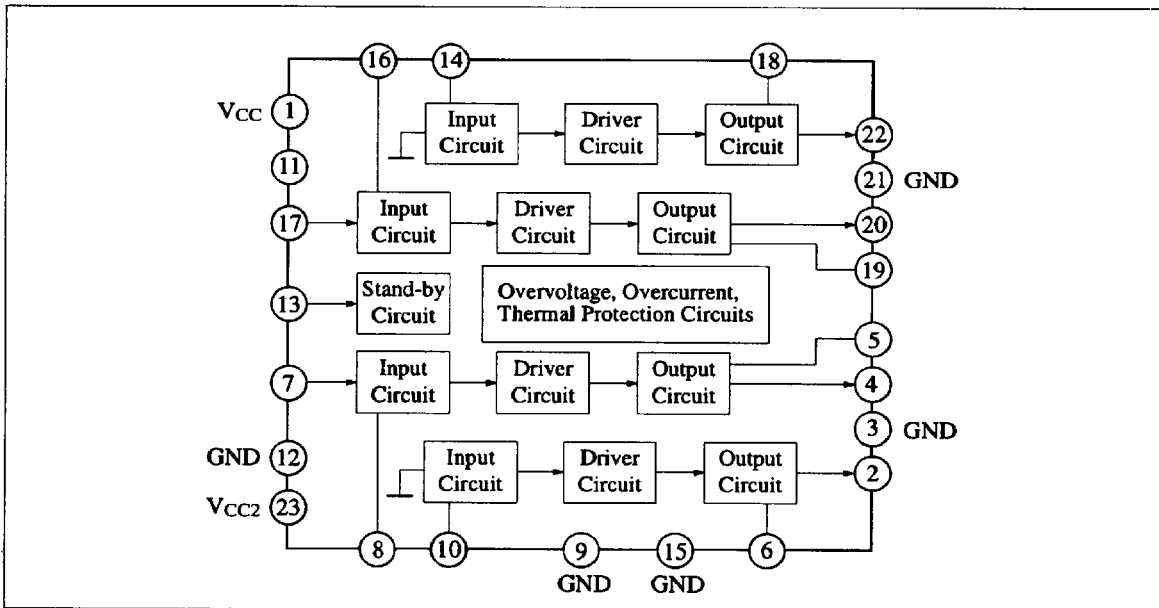

■ Absolute Maximum Ratings (Ta=25°C)

Item	Symbol	Rating	Unit
Supply Voltage	V _{CC} *1	24	V
Supply Current	I _{CC}	6	A
Supply Voltage Surge	V _{CC(surge)} *2	50	V
Power Dissipation	P _D *3	62.5	W
Operating Ambient Temperature	T _{opr}	-30 ~ +75	°C
Storage Temperature	T _{stg}	-55 ~ +150	°C

*1 Non-signal *2 Time = 0.2s *3 R_{θj-c} = 2°C/W

Operating voltage range: V_{CC} = 8V ~ 18V

■ Electrical Characteristics (V_{CC}=13.2V, R_L=4Ω, f=1kHz, Ta=25°C)

Item	Symbol	Test Circuit	Condition	min.	typ.	max.	Unit
Quiescent Current	I _{CQ}	1	V _{in} = 0mV		110	200	mA
Output Noise Voltage	V _{no1} *	1	V _{in} = 0mV, R _g = 10kΩ		0.6	1.5	mV
Voltage Gain	G _v	1	V _{in} = 5mV	49.5	51.5	53.5	dB
Total Harmonic Distortion	THD ₁	1	V _{in} = 5mV		0.15	0.75	%
Maximum Output Power	P _O	1	THD = 10%	14	18		W
Ripple Rejection	RR ₁ *	1	R _g = 0Ω, V _{in} = 0mV, V _r = 300mV, f _r = 120Hz	45	55		dB
Output Offset Voltage	V _{O(offset)}	1	V _{in} = 0mV	-300	0	+300	mV
Channel Balance	CB	1	V _{in} = 5mV	-1	0	+1	dB
Output Noise Voltage	V _{no2} *	2	V _{in} = 0mV, R _g = 10kΩ, G _v = 41dB		0.21		mV
Total Harmonic Distortion	THD ₂	2	V _{in} = 10mV, G _v = 41dB		0.05		%
Ripple Rejection	RR ₂ *	2	R _g = 0Ω, V _{in} = 0mV, V _r = 300mV, f _r = 120Hz, G _v = 41dB		64		dB

* With 15Hz ~ 30kHz (12dB/OCT) filter

■ Pin

Pin No	Pin Name	Pin No	Pin Name
1	V _{CC}	13	Stand-by
2	Output Ch.1	14	N.F.B. Ch.2
3	GND (Output Ch.1)	15	GND (Input Ch.2)
4	Output Ch.1	16	N.F.B. Ch.2
5	Bootstrap Ch.1	17	Input Ch.2
6	Bootstrap Ch.1	18	Bootstrap Ch.2
7	Input Ch.1	19	Bootstrap Ch.2
8	N.F.B. Ch.1	20	Output Ch.2
9	GND (Input Ch.1)	21	GND (Output Ch.2)
10	N.F.B. Ch.1	22	Output Ch.2
11	Ripple Filter	23	V _{CC2}
12	GND (Input)		

■ 6932852 0013838 881 ■

219

Panasonic

Test Circuit 1 (IcQ, Vno1, GV, THD1, PO, RR1, VO(offset), CB)

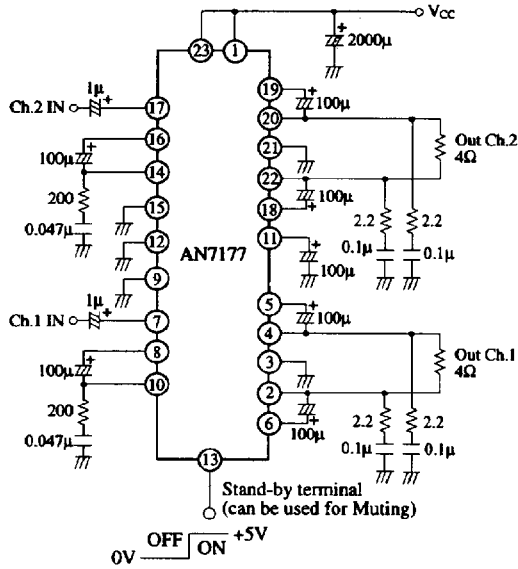

Test Circuit 2 (Vno2, THD2, RR2)

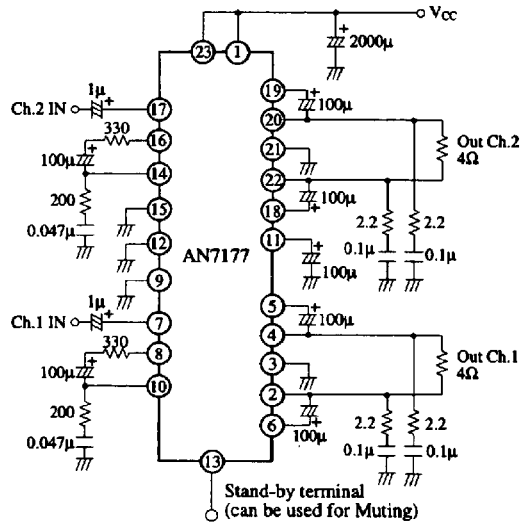

■ **Application Circuit**

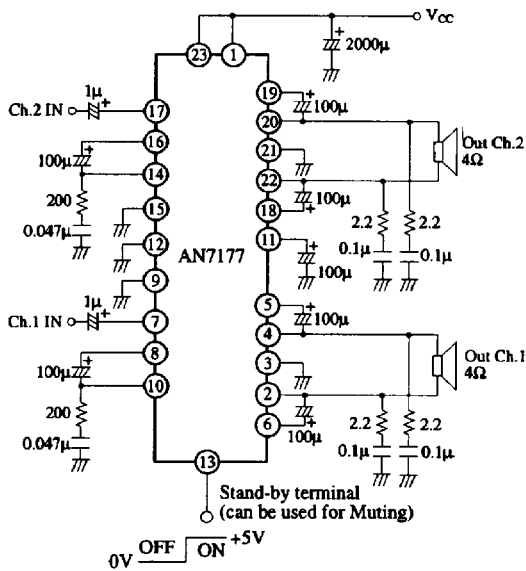

■ **Characteristics Curve**

- (1) $T_c = T_a$ ($\theta_{j-c} = 2^\circ C/W$)
- (2) With a $100cm^2 \times 3mm$ Al heat sink (black colour coated) or a $200cm^2 \times 2mm$ Al heat sink (not lacquered)
- (3) With a $100cm^2 \times 2mm$ Al heat sink (not lacquered)
- (4) Without heat sink

