

Modular Mid-Range PICmicro® KEELOQ® Decoder in C

Author: *Lucio Di Jasio*
Microchip Technology Inc.

OVERVIEW

This application note describes a KEELOQ code hopping decoder implemented on a Microchip Mid-range Enhanced FLASH MCU (PIC16F872). The software has been designed as a group of independent modules (standard C source files "C").

For clarity and ease of maintenance, each module covers a single function. Each module can be modified to accommodate a different behavior, support a different MCU, and/or a different set of peripherals (memories, timers, etc.).

KEY FEATURES

The set of modules presented in this application note implement the following features:

- Source compatible with HITECH and CCS C compilers
- Pin out compatible with PICDEM-2 board
- Normal Learn mode
- Learn up to 8 transmitters, using the internal EEPROM memory of PIC16F872
- Interrupt driven Radio Receive (PWM) routine
- Compatible with all existing KEELOQ hopping code encoders with PWM transmission format selected, operating in "slow mode" ($T_E = 400 \mu s$)
- Automatic synchronization during receive, using a 4 MHz RC oscillator

FIGURE 1: DECODER PIN OUT

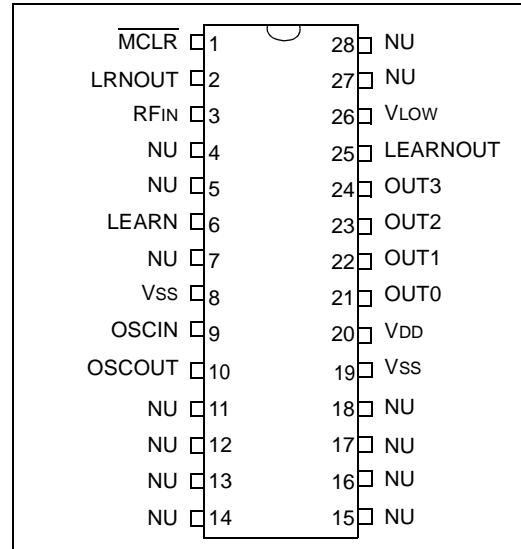

TABLE 1: FUNCTIONAL INPUTS AND OUTPUTS

Pin Name	Pin Number	Input/Output	Function
RFIN	3	I	Demodulated PWM signal from RF receiver
LEARN	6	I	Input to enter learn mode
LEARN-OUT	25	O	Output to show the status of the learn process
OUT0..3	21,22,23, 24	O	Function outputs, correspond to encoder input pin
VLOW	26	O	Low Battery indicator, as transmitted by the encoder
VDD	20	PWR	5V power supply
VSS	19, 8	GND	Common ground

Note: All NU pins are tristate

Notice:

This is a non-restricted version of Application Note AN745 which is available under the KEELOQ License Agreement. The license agreement can be ordered from the Microchip Literature Center as DS40149.

AN744

DESIGN OBJECTIVES

Each module has been designed for maximum simplicity and maintainability. Whenever possible, we favored clarity of design over efficiency in order to show the basic concepts of the design of a KEELOQ decoder without the constraints of previous PIC16C5X implementations such as limited RAM, STACK, or other resources.

To achieve maximum ease in maintenance, we adopted "modern" C language programming techniques, specifically:

- All pin assignments are mapped through `#define` directives. This results in almost complete code independence from the specific pin out chosen
- Drivers to peripherals that are specific to a given processor type (such as PIC16F872) have been encapsulated in more generic modules
- Function input and output values are documented
- Pseudo-graphical representation of the data structures used and program flow is commented whenever possible

Although the code can be compiled in a set of independent object files and then linked together to build the actual application, we kept all the modules included in line with the main module to retain compatibility with compilers that have no linker such as CCS PIC C.

MODULES OVERVIEW

The code presented in this application note is composed of the following basic modules:

RXI.C	interrupt driven receiver
KEYGEN.C	KEELOQ key generation routines implementing Normal Mode
FASTDEC.C	KEELOQ decrypt routine
MEM-87X.C	PIC16F87X EEPROM driver
TABLE.C	transmitters table memory management (linear list)
MAIN.C	the actual initialization and main loop

FIGURE 2: MODULES OVERVIEW

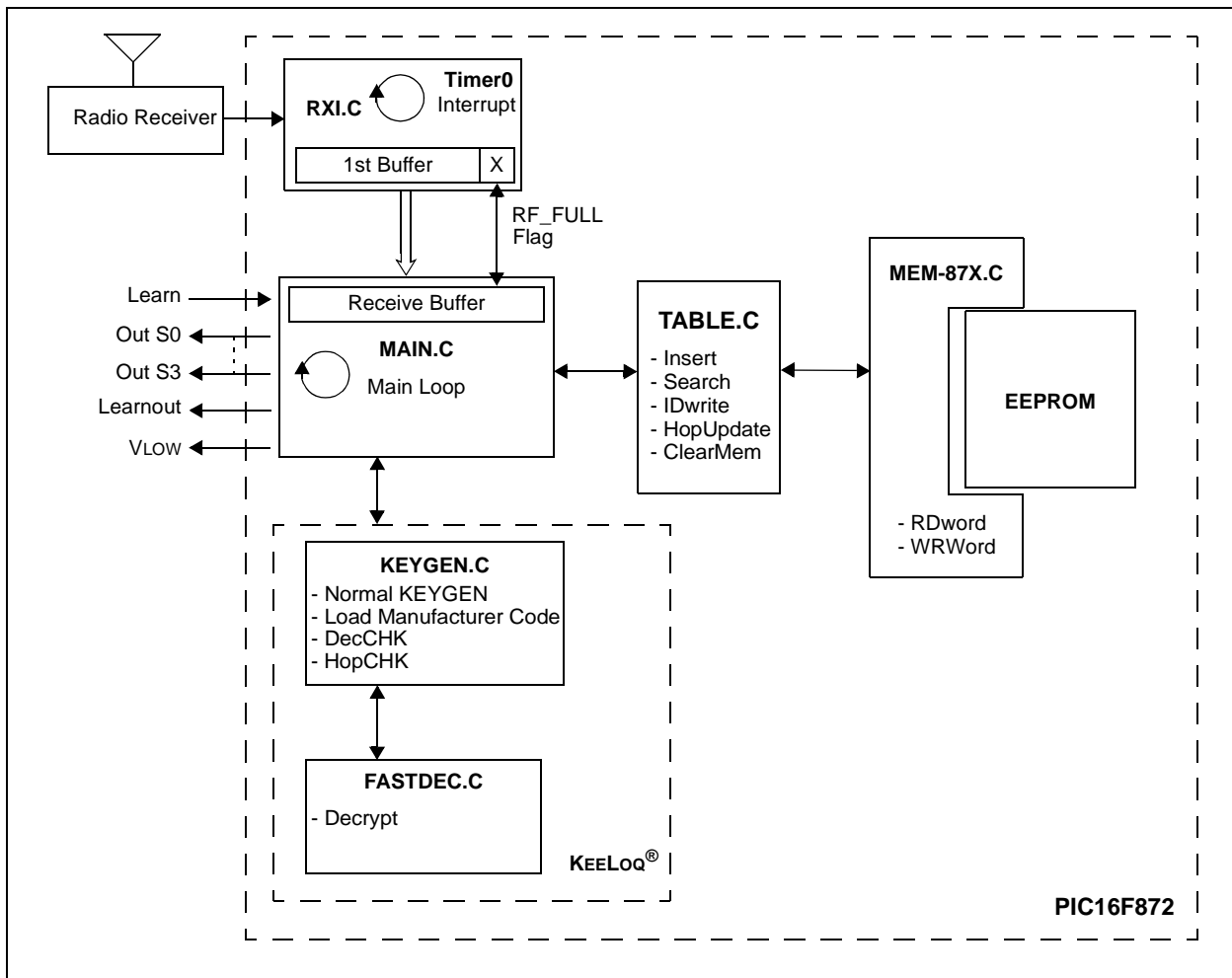

RECEIVER MODULE

The receiver module has been developed around a fast and independent Interrupt Service Routine (ISR). The whole receiving routine is implemented as a simple state machine that operates on a *fixed* time base. This can be used to produce a number of virtual timers. The operation of this routine is completely transparent to the main program and similar to a UART. In fact, the interrupt routine consumes only 30% of the computational power of the MCU working in the background .

After a complete code-word of 66 bits has been properly received and stored in a 9 bytes buffer, a status flag (RF_FULLL) is set and the receiver becomes idle.

It is the responsibility of the main program to make use of the data in the buffer and to clear the flag to enable the receiving of a new code-word.

In order to be compatible with all KEELOQ encoders, with or without oscillator tuning capabilities, the receiver routine constantly attempts to resynchronize

with the first rising edge of every bit in the incoming code-word. This allows the decoder to operate from an inexpensive (uncalibrated) RC clock. In doing so, the last rising edge/bit of every code-word is lost (resulting in an effective receive buffer capacity of 65-bit).

For HCS20X and HCS30X encoders this implies that the REPEAT bit (being the 66th) cannot be captured. While for Advanced Encoders like the HCS36X or HCS4XX, the reader can easily modify the definition of the constant BIT_NUM to 68 to receive all bits transmitted with exception of the last queue bit Q1 (being the 69th), again rarely used.

The only resource/peripheral used by this routine is Timer0 and the associated Overflow Interrupt. This is available on every mid-range PICmicro microcontroller. Timer0 is reloaded on overflow, creating a time base (of about $1/3 T_E = 138 \mu s$). The same interrupt service routine also provides a virtual 16-bit timer, derived from the same base period, called XTMR.

FIGURE 3: CODE-WORD TRANSMISSION FORMAT

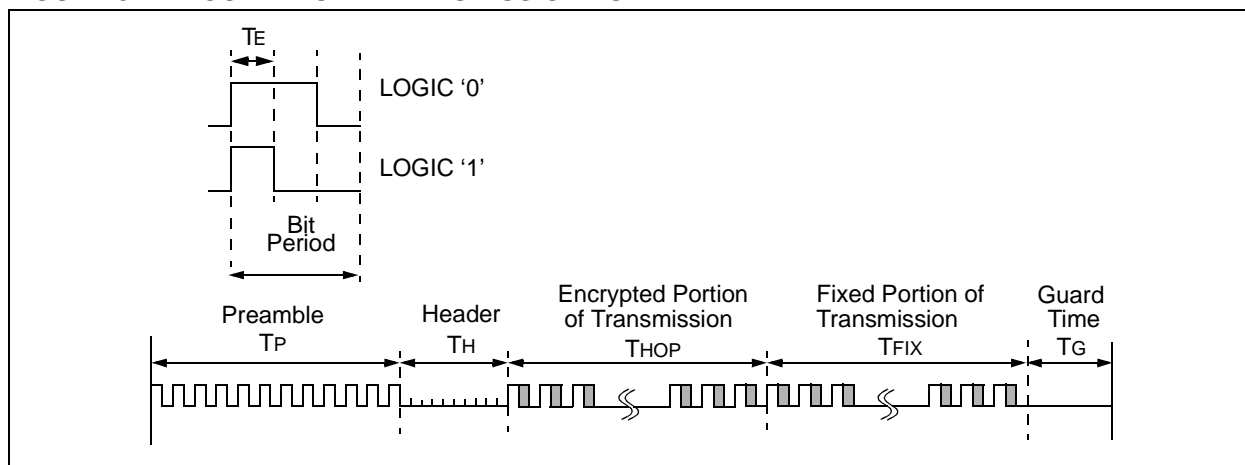
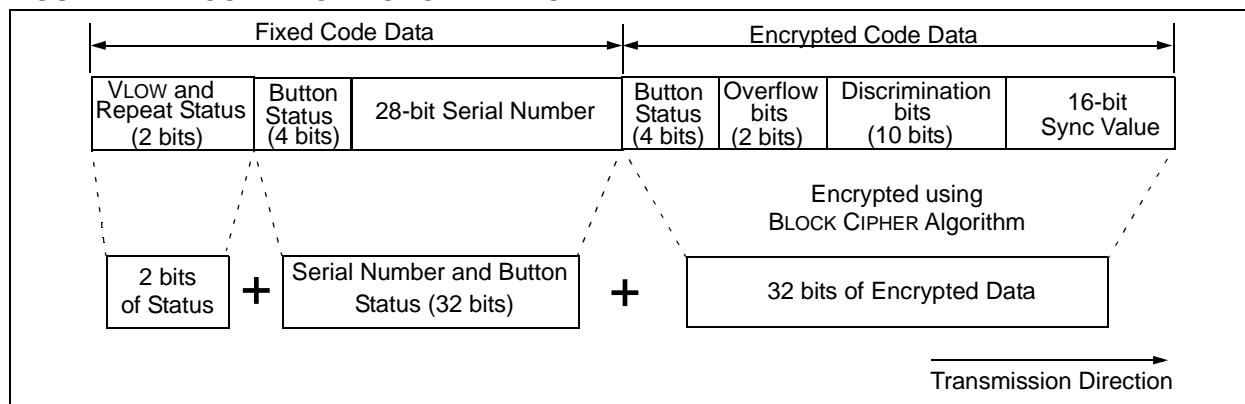

FIGURE 4: CODE-WORD ORGANIZATION



Since the radio input is polled (for 1 μ s) on multiples of the base period (138 μ s), the chance of a glitch (short noise pulse) disturbing the receiver is reduced.

Further, since the time base produced is constant, the same interrupt service routine could easily be extended to implement a second UART as a separate state machine for full duplex asynchronous communication up to 1,200 baud at 4 MHz.

Note: This would also require the main oscillator to be crystal based.

Other implementations of the same receiver module can be obtained using other peripherals and detection techniques. These include:

- Using the INT pin and selectable edge interrupt source
- Using the Timer1 and CCP module in capture mode
- Using comparator inputs interrupt

All of these techniques pose different constraints on the pin out, or the PICmicro MCU, that can be used. This would lead to different performances in terms of achievable immunity from noise and or CPU overhead, etc.

FAST DECRYPTION MODULE

This module contains an implementation of the KEELOQ decryption algorithm that has been optimized for speed on a mid-range PICmicro microcontroller. It allows fast decryption times for maximum responsiveness of the system even at 4 MHz clock.

The decryption function is also used in all learning schemes and represents the fundamental building block of all KEELOQ decoders.

KEY GENERATION MODULE

This module shows a simple and linear implementation of the Normal Learn Key Generation .

This module uses the KEELOQ Decrypt routine from the Fast Decryption module to generate the key at every received code-word instead of generating it during the learn phase and storing it in memory. The advantage is a smaller Transmitter Record of 8 bytes instead of 16 bytes (see Table 2). This translates in a double number of transmitters that can be learned using the 64 byte internal EEPROM available inside the PIC16F872. This space reduction comes at the expense of more computational power required to process every code-word. When a new code-word is received, the key generation algorithm is applied (Normal Learn) and the resulting Description key is placed in the array DKEY [0 . . 7]. During a continuous transmission (the user is holding the button on the transmitter), the key generation is not repeated, to save time, the last computed Decryption Key value is used safely instead (the serial number being the same).

Due to double buffering of the receiver and the PICmicro MCU execution speed and efficiency (even running at 4 MHz only), it is possible to receive and decrypt, at the same time, each and every incoming code-word.

For an overview of some of the different security levels that can be obtained through the use of different key generation/management schemes, refer to the "Secure Data Products Handbook" [DS40168] (Section 1, KEELOQ Comparison Chart, Security Level Summary).

A detailed description of the Normal Learn key generation scheme can be found in Technical Brief TB003 "An Introduction To KEELOQ Code Hopping" [DS91002].

More advanced Key Generation Schemes can be implemented replacing this module with the techniques described in Technical Brief TB001 "Secure Learning RKE Systems Using KEELOQ Encoders" [DS91000].

TABLE MODULE

One of the major tasks of a decoder is to properly maintain a database that contains all the unique ID's (serial numbers) of the learned transmitters. In most cases, the database can be as simple as a single table, which associates those serial numbers to the synchronization counters (that are at the heart of the hopping code technology).

This module implements the easiest of all methods, a simple "linear list" of records.

Each transmitter learned is assigned a record of 8 bytes (shown in Table 2), where all the relevant information is stored and regularly updated.

TABLE 2: TRANSMITTER RECORD

Offset	Data	Description
+0	FCODE	Function code (4 bits) and upper 4 Serial Number bits [24..28]
+1	IDLo	Serial Number bits [0..7]
+2	IDHi	Serial Number bits [8..15]
+3	IDMi	Serial Number bits [16..23]
+4	SYNCH	Sync Counter 8 MSB
+5	SYNCL	Sync Counter 8 LSB
+6	SYNCH2	Second copy of SYNCH
+7	SYNCL2	Second copy of SYNCL

The 16-bit synchronization counter value is stored in memory twice because it is the most valuable piece of information in this record. It is continuously updated at every button press on the remote. When reading the two stored synchronous values, the decoder should verify that the two copies match. If not, it can adopt any safe resync or disable technique required depending on the desired system security level .

The current implementation limits the maximum number of transmitters that can be learned to eight. This is due to the size of the internal EEPROM of the PIC16F872.

This number can be changed to accommodate different PICmicro models and memory sizes by modifying the value of the constant `MAX_USER`.

The simple "linear list" method employed can be scaled up to some tens of users. But due to its simplicity, the time required to recognize a learned transmitter grows linearly with the length of the table.

It is possible to reach table sizes of thousands of transmitters by replacing this module with another module that implements a more sophisticated data structure like a "Hash Table" or other indexing algorithms.

Again due to the simplicity of the current solution, it is not possible to selectively delete a transmitter from memory. The only delete function available is a Bulk Erase (complete erase of all the memory contents) that happens when the user presses the Learn button for up to 10 seconds. (The LED will switch off. At the release of the button, it will flash once to acknowledge the delete command). To allow for selective transmitter removal from memory, more sophisticated techniques will be analyzed in future application notes, by simply replacing/updating this module.

MEM-87X MODULE

This module is optimized to drive the internal EEPROM of the PIC16F87X device.

The module make the memory generically accessible by means of two routines `RDword` and `WRword` that respectively read and write a 16-bit value out of an even address specified in parameter `IND`.

Replacing this module with the appropriate drivers, (and adapting the pin out) make possible the use of any kind of nonvolatile memory. This includes internal and external serial EEPROMs (Microwire[®], SPI[™] or I²C[™] bus) of any size up to 64 Kbytes.

THE MAIN PROGRAM

The main program is reduced to a few pages of code. The behavior is designed to mimic the basic behavior of the HCS512 integrated decoder, although just the parallel output is provided (no serial interface).

Most of the time, the main loop goes idle waiting for the receiver to complete reception a full code-word.

Double buffering of the receiver is done in RAM, in order to immediately re-enable the reception of new codes and increase responsiveness and perceived range.

CONCLUSION

The C language source increases the readability of the program structure and eases the maintenance. This benefit has come at the cost of the program size. That in terms of memory words, has considerably increased over the equivalent code written in assembly (more than 30% larger).

Selecting a FLASH PICmicro microcontroller from the mid-range family as the target MCU allows us to make the code simpler and cleaner. It also provides larger RAM memory space and a deeper hardware stack. Interrupts have been used to "virtualize" the receiving routine as a software peripheral and to free the design of the hard real time constraint that it usually poses. Still, many of the resources available on the PIC16F872 are left unused and available to the designer. These include:

- Timer1, a 16-bit timer
- Timer1 oscillator, a low power oscillator for real time clock
- CCP module, capable of capture, compare and PWM generation
- Timer2, an 8-bit timer, with auto reload
- 10-bit A/D converter with a 5 channel input multiplexer

We resisted introducing extra features and optimizations in favor of clarity. For example:

- Speed optimizations and code compacting
- More complex key generation schemes
- Multiple manufacturer codes
- Co-processor functionality
- Advanced user entry and deletion commands
- Large memory tables (up to 8,000 users)
- Serial interface to PDAs and/or terminals for memory management and logging

These are left as exercises to the advanced reader/designer or as suggestions for further application notes.

AN744

MEMORY USAGE FUNCTION HEADERS

Compiling with HITECH 7.86r3

Memory Usage Map:

Program ROM	\$0000 - \$00A8	\$00A9	(169) words
Program ROM	\$04Af - \$07FF	\$0351	(849) words
Program ROM	\$2000 - \$2005	\$0006	(6) words
Program ROM	\$2007 - \$2007	\$0001	(1) words
		\$0401	(1025) words total Program ROM
Bank 0 RAM	\$0021 - \$006D	\$004D	(77) bytes
Bank 0 RAM	\$0070 - \$0074	\$0005	(5) bytes
		\$0052	(82) bytes total Bank 0 RAM
Bank 0 Bits	\$0100 - \$0105	\$0006	(6) bits total Bank 0 bits

CCS PCW C Compiler, Version 2.535, 4511

Filename: D:\WORK\SMAD\AN\DECC\MAIN.LST

ROM used: 1155 (28%)
1155 (28%) including unused fragments

RAM used: 71 (37%) at main () level
84 (44%) worst case

Stack: 4 worst case (3 in main +1 for interrupts)

REFERENCES

KEELOQ Code Hopping Decoder on a PIC16C56	AN642	DS00642
Converting NTQ105/106 Designs to HCS200/300s	AN644	DS00644
Code Hopping Security System on a PIC16C57	AN645	DS00645
Secure Learn Code Hopping Decoder on a PIC16C56	AN652	DS00652
KEELOQ Simple Code Hopping Decoder	AN659	DS00659
KEELOQ Code Hopping Decoder on a PIC16C56 (public version)	AN661	DS00661
Secure Learn Code Hopping Decoder on a PIC16C56 (public version)	AN662	DS00662
KEELOQ Simple Code Hopping Decoder (public version)	AN663	DS00663
Using KEELOQ to Generate Hopping Passwords	AN665	DS00665
PICmicro Mid-Range MCU Code Hopping Decoder	AN662	DS00672
HCS410 Transponder Decoder using a PIC16C56	AN675	DS00675
Modular PICmicro Mid-Range MCU Code Hopping Decoder	AN742	DS00742
Secure Learning RKE Systems Using KEELOQ Encoders	TB001	DS91000
An Introduction to KEELOQ Code Hopping	TB003	DS91002
A Guide to Designing for EuroHomelink Compatibility	TB021	DS91021
KEELOQ Decryption & IFF Algorithms	TB030	DS91030
KEELOQ Decryption Routines in C	TB041	DS91041
Interfacing a KEELOQ Encoder to a PLL Circuit	TB042	DS91042
KEELOQ CRC Verification Routines	TB043	DS91043

Software License Agreement

The software supplied herewith by Microchip Technology Incorporated (the “Company”) for its PICmicro® Microcontroller is intended and supplied to you, the Company’s customer, for use solely and exclusively on Microchip PICmicro Microcontroller products.

The software is owned by the Company and/or its supplier, and is protected under applicable copyright laws. All rights are reserved. Any use in violation of the foregoing restrictions may subject the user to criminal sanctions under applicable laws, as well as to civil liability for the breach of the terms and conditions of this license.

THIS SOFTWARE IS PROVIDED IN AN “AS IS” CONDITION. NO WARRANTIES, WHETHER EXPRESS, IMPLIED OR STATUTORY, INCLUDING, BUT NOT LIMITED TO, IMPLIED WARRANTIES OF MERCHANTABILITY AND FITNESS FOR A PARTICULAR PURPOSE APPLY TO THIS SOFTWARE. THE COMPANY SHALL NOT, IN ANY CIRCUMSTANCES, BE LIABLE FOR SPECIAL, INCIDENTAL OR CONSEQUENTIAL DAMAGES, FOR ANY REASON WHATSOEVER.

APPENDIX A: DECHIT H SOURCE CODE

```
// Module DECHIT.h
//
// include this file when using the HiTech C compiler
//
#define HITECH

#include <pic.h>
#include <string.h>

typedef unsigned char byte;
typedef signed char sbyte;
typedef signed int word;

#define TRUE    1
#define FALSE   0
#define ON      1
#define OFF     0

#define BIT_TEST( x, y) (( (x) & (1<<(y))) != 0)

// set config word
__CONFIG( UNPROTECT | (FOSC1 | FOSC0) | BODEN);
__IDLOC(0x1234);           // define ID locations
```

APPENDIX B: DECCCS H SOURCE CODE

```
// Module DECCCS.h
//
// include this file when using the CCS C compiler
//
#define CCS

#DEVICE PIC16C63

typedef short bit;           // one bit
typedef unsigned int byte;   // one byte unsigned
typedef signed int sbyte;    // one byte signed
typedef signed long word;    // one word signed

// un-supported directives
#define static
#define volatile
#define interrupt

#define TRUE 1
#define FALSE 0
#define ON 1
#define OFF 0

//
// F872 special function registers
//
#byte TMR0 = 0x01           // Timer 0
#bit T0IF = 0x0B.2         // Timer 0 interrupt flag
#bit T0IE = 0x0B.5         // Timer 0 interrupt enable
#bit GIE = 0x0B.7          // Global Interrupt Enable

#byte OPTION = 0x81         // prescaler timer0 control
#byte ADCON1 = 0x9f         // A/D converter control

#byte TRISA = 0x85          // PORT A
#byte PORTA = 0x05
#bit RA0 = 0x05.0
#bit RA1 = 0x05.1
#bit RA2 = 0x05.2
#bit RA3 = 0x05.3
#bit RA4 = 0x05.4
#bit RA5 = 0x05.5

#byte TRISB = 0x86          // PORT B
#byte PORTB = 0x06
#bit RB0 = 0x06.0
#bit RB1 = 0x06.1
#bit RB2 = 0x06.2
#bit RB3 = 0x06.3
#bit RB4 = 0x06.4
#bit RB5 = 0x06.5
#bit RB6 = 0x06.6
#bit RB7 = 0x06.7

#byte TRISC = 0x87          // PORT C
#byte PORTC = 0x07

// internal EEPROM access
#byte EEADR = 0x10d
#byte EEDATA = 0x10c
#byte EECON1 = 0x18c
#byte EECON2 = 0x18d
#bit WR = 0x18c.1
```



```
#bit RD = 0x18c.0
#bit WREN = 0x18c.2
#bit EEPGD = 0x18c.7

// macro versions of EEPROM write and read
#defineEEPROM_WRITE(addr, value) while(WR)con-
tinue;EEADR=(addr);EEDATA=(value);EEPGD=0;GIE=0;WREN=1;\
    EECON2=0x55;EECON2=0xAA;WR=1;WREN=0
#defineEEPROM_READ(addr) ((EEADR=(addr)), (EEPGD=0), (RD=1), EEDATA)

// configuration and ID locations
#FUSES RC, NOWDT, NOPROTECT, BROWNOUT
#ID 0x1234
```

APPENDIX C: MAIN C SOURCE CODE

```
// *****
// Filename:   MAIN.c
// *****
// Author:    Lucio Di Jasio
// Company:   Microchip Technology
// Revision:  Rev 1.00
// Date:     08/07/00
//
// Keelq Normal Learn Decoder on a mid range PIC
// full source in C
//
// Compiled using HITECH PIC C compiler v.7.93
// Compiled using CCS   PIC C compiler v. 2.535
// *****

#include "decccs.h" // uncomment for CCS compiler
#include "dechit.h" // uncomment for HiTech compiler
//
//-----
// I/O definitions for PIC16F872
// compatible with PICDEM-2 demo board
//
// +-----+
// Reset  -|MCLR   0   RB7|- NU(ICD data)
// (POT)  -|RA0    RB6|- NU(ICD clock)
// RFin   -|RA1    RB5|- Vlow(Led)
// NU     -|RA2    RB4|- LearnOut (Led)
// NU     -|RA3    PRG/RB3|- Out3 (Led)
// Learn  -|RA4/TOCKI  RB2|- Out2 (Led)
// NU     -|RA5    RB1|- Out1 (Led)
// GND    -|Vss    INT/RB0|- Out0 (Led)
// XTAL   -|OSCIN  Vdd|- +5V
// XTAL   -|OSCOUT Vss|- GND
// NU     -|RC0    RX/RC7|- NU(RS232)
// NU     -|RC1    TX/RC6|- NU(RS232)
// NU(SW3) -|RC2/CCP1  RC5|- NU
// NU     -|RC3/SCL  SDA/RC4|- NU
// +-----+
//

#define RFin   RA1           // i radio signal input
#define Learn  RA4           // i learn button

#define Out0   RB0           // o S0 output
#define Out1   RB1           // o S1 output
#define Out2   RB2           // o S2 output
#define Out3   RB3           // o S3 output
#define Led    RB4           // o LearnOut Led
#define Vlow   RB5           // o low battery

#define MASKPA 0xff         // port A I/O config (all input)
#define MASKPB 0xc0         // port B I/O config (6 outputs)
#define MASKPC 0xff         // port C I/O config (NU)

// -----global variables -----
byte Buffer[9];           // receive buffer

//-----
//
```

```

// keeloq receive buffer map
//
// | Plain text | Encrypted
// RV000000.KKKKIIIII.IIIIIIII.IIIIIIII.IIIIIIII.KKKKOIDD.DDDDDDDD.SSSSSSS.SSSSSSS
//      8      7      6      5      4      3      2      1      0
//
// I=S/N  -> SERIAL NUMBER      (28 BIT)
// K=KEY  -> buttons encoding   (4 BIT)
// S=Sync -> Sync counter       (16 BIT)
// D=Disc -> Discrimination bits (10 BIT)
// R=Rept -> Repeat/first       (1 BIT)
// V=Vlow -> Low battery        (1 BIT)
//
//-- alias -----
//
#define HopLo Buffer[0] //sync counter
#define HopHi Buffer[1] //
#define DisLo Buffer[2] //discrimination bits LSB
#define DOK Buffer[3] //Disc. MSB + Ovf + Key
#define IDLo Buffer[4] //S/N LSB
#define IDMi Buffer[5] //S/N
#define IDHi Buffer[6] //S/N MSB

#define S0 5 // Buffer[3] function codes
#define S1 6 // Buffer[3] function codes
#define S2 7 // Buffer[3] function codes
#define S3 4 // Buffer[3] function codes
#define VFlag 7// Buffer[8] low battery flag

//----- flags defines -----
bit FHopOK; // Hopping code verified OK
bit FSame; // Same code as previous
bit FLearn; // Learn mode active
bit F2Chance; // Resync required

//-----
// timings
//
#define TOUT 5 // 5 * 71ms = 350ms output delay
#define TFLASH 2 // 4 * 71ms = 280ms half period
#define TLEARN 255 // 255 * 71ms = 18s learn timeout

//byte Flags; // various flags
byte CLearn, CTLearn; // learn timers and counter
byte CFlash, CTFlash; // led flashing timer and counter
byte COut; // output timer
byte FCode; // function codes and upper nibble of serial number

word Dato; // temp storage for read and write to mem.
word Ind; // address pointer to record in mem.
word Hop; // hopping code sync counter
word EHop; // last value of sync counter (from EEPROM)
word ETemp; // second copy of sync counter

//
// interrupt receiver
//
#include "rxim.c"

//
// external modules
//
#include "mem-87x.c" // EEPROM I2C routines

```

AN744

```
#include "table.c"           // TABLE management
#include "keygen.c"          // Keeloq decrypt and normal keygen

//
// prototypes
//
void Remote( void);

//
// MAIN
//
// Main program loop, I/O polling and timing
//
void main ()
{
    // init
    ADCON1 = 0x7;           // disable analog inputs
    TRISA = MASKPA;        // set i/o config.
    TRISB = MASKPB;
    TRISC = MASKPC;
    PORTA = 0;              // init all outputs
    PORTB = 0;
    PORTC = 0;
    OPTION = 0x8f;         // prescaler assigned to WDT,
                          // TMR0 clock/4, no pull ups

    CTLearn = 0;           // Learn debounce
    CLearn = 0;            // Learn timer
    COut = 0;              // output timer
    CFlash = 0;            // flash counter
    CTFlash = 0;           // flash timer
    FLearn = FALSE;        // start in normal mode
    F2Chance = FALSE;      // no resynchronization required

    InitReceiver();        // enable and init the receiver state machine

    // main loop
    while ( TRUE)
    {
        if ( RFFull)        // buffer contains a message
            Remote();

        // loop waiting 512* period = 72ms
        if ( XTMR < 512)
            continue;       // main loop

// once every 72ms
        XTMR=0;

        // re-init fundamental registers
        ADCON1 = 0x7;       // disable analog inputs
        TRISA = MASKPA;    // set i/o config.
        TRISB = MASKPB;
        TRISC = MASKPC;
        OPTION = 0x0f;      // prescaler assigned to WDT, TMR0 clock/4, pull up
        TOIE = 1;
        GIE = 1;

        // poll learn
        if ( !Learn)        // low -> button pressed
        {
            CLearn++;
        }
    }
}
```

```

// pressing Learn button for more than 10s -> ERASE ALL
if (CLearn == 128) // 128 * 72 ms = 10s
{
    Led = OFF; // switch off Learn Led
    while( !Learn); // wait for button release
    Led = ON; // signal Led on
    ClearMem(); // erase all comand!
    COut = TOUT; // single long flash pulse time
                // timer will switch off Led
    CLearn = 0; // reset learn debounce
    FLearn = FALSE; // exit learn mode
}

// normal Learn button debounce
if (CLearn == 4) // 250ms debounce
{
    FLearn = TRUE; // enter learn mode comand!
    CTLearn = TLEARN; // load timeout value
    Led = ON; // turn Led on
}
}
else CLearn=0; // reset counter

// outputs timing
if ( COut > 0) // if timer running
{
    COut--;
    if ( COut == 0) // when it reach 0
    {
        Led = OFF; // all outputs off
        Out0 = OFF;
        Out1 = OFF;
        Out2 = OFF;
        Out3 = OFF;
        Vlow = OFF;
    }
}

// Learn Mode timeout after 18s (TLEARN * 72ms)
if ( CTLearn > 0)
{
    CTLearn--; // count down
    if ( CTLearn == 0) // if timed out
    {
        Led = OFF; // exit Learn mode
        FLearn = FALSE;
    }
}

// Led Flashing
if ( CFlash > 0)
{
    CFlash--; // count down
    if ( CFlash == 0) // if timed out
    {
        CFlash = TFLASH; // reload timer
        CFlash--; // count one flash
        Led = OFF; // toggle Led
        if ( CFlash & 1)
            Led = ON;
    }
}
} // main loop
} // main

```

AN744

```
//
// Remote Routine
//
// Decrypts and interprets receive codes
// Does Normal Operation and Learn Mode
//
// INPUT:  Buffer contains the received code word
//
// OUTPUT: S0..S3 and LearnOut
//
void Remote()
{
    // a frame was received and is stored in the receive buffer
    // move it to decryption Buffer, and restart receiving
    memcpy( Buffer, B, 9);
    RFFull = FALSE;                // ready to receive a new frame

    // decoding
    NormalKeyGen();                // compute the decryption key
    Decrypt();                     // decrypt the hopping code portion

    if ( DecCHK() == FALSE)        // decription failed
        return;

    if ( FLearn)
    {
        // Learn Mode

        if ( Find()== FALSE)
            // could not find the Serial Number in memory
            {
                if ( !Insert())    // look for new space
                    return;        // fail if no memory available
            }

        // ASSERT Ind is pointing to a valid memory location
        IDWrite();                 // write Serial Number in memory
        FHopOK = TRUE;            // enable updating Hopping Code
        HopUpdate();              // Write Hoping code in memory

        CFlash = 32;              // request Led flashing
        CTFlash = TFLASH;         // load period timer
        Led = TRUE;               // start with Led on
        FLearn = FALSE;           // terminate successfully Learn
    } // Learn

    else // Normal Mode of operation
    {
        if ( Find()== FALSE)
            return;
        if ( !HopCHK())           // check Hopping code integrity
            return;

        if ( FSame)               // identified same code as last memorized
            {
                if ( COut >0)     // if output is still active
                    COut = TOUT;  // reload timer to keep active
                else
                    return;       // else discard
            }

        else                       // hopping code incrementing properly
            {

```

```
HopUpdate();                // update memory

// set outputs according to function code
if ( BIT_TEST(Buffer[3],S0))
    Out0 = ON;
if ( BIT_TEST(Buffer[3],S1))
    Out1 = ON;
if ( BIT_TEST(Buffer[3],S2))
    Out2 = ON;
if ( BIT_TEST(Buffer[3],S3))
    Out3 = ON;

// set low battery flag if necessary
if ( BIT_TEST(Buffer[8],VFlag))
    Vlow = ON;

// check against learned function code
if ( (( Buffer[7] ^ FCode) & 0xf0) == 0)
    Led = ON;

// init output timer
    COut = TOUT;
} // recognized
} // normal mode
} // remote
```

APPENDIX D: RXI C SOURCE CODE

```
// *****
// Filename:   RXI.c
// *****
// Author:    Lucio Di Jasio
// Company:   Microchip Technology
// Revision:  Rev 1.00
// Date:     08/07/00
//
// Interrupt based receive routine
//
// Compiled using HiTech PIC C compiler v.7.93
// Compiled using CCS PIC C compiler v.2.535
// *****
#define CLOCK      4      // MHz
#define TE        400    // us
#define OVERSAMPLING 3
#define PERIOD    TE/OVERSAMPLING*4/CLOCK

#define NBIT      65     // number of bit to receive -1

byte B[9];          // receive buffer

static byte RFstate; // receiver state
static sbyte RFcount; // timer counter
static byte Bptr;    // receive buffer pointer
static byte BitCount; // received bits counter
word XTMR;          // 16 bit extended timer

volatile bit RFFull; // buffer full
volatile bit RFBBit; // sampled RF signal

#define TRFreset 0
#define TRFSYNC 1
#define TRFUNO 2
#define TRFZERO 3

#define HIGH_TO -10 // longest high Te
#define LOW_TO 10 // longest low Te
#define SHORT_HEAD 20 // shortest Thead accepted 2,7ms
#define LONG_HEAD 45 // longest Thead accepted 6,2ms

#pragma int_rtcc // install as interrupt handler (comment for HiTech!)
interrupt
rxi()
{
    // this routine gets called every time TMR0 overflows
    RFBBit = RFIn; // sampling RF pin verify!!!
    TMR0 -= PERIOD; // reload
    TOIF = 0;

    XTMR++; // extended 16 long timer update

    if (RFFull) // avoid overrun
        return;

    switch( RFstate) // state machine main switch
    {
        case TRFUNO:
            if ( RFBBit == 0)
            { // falling edge detected ----+
                // |
            }
        }
    }
}
```



```

        //
        RFstate= TRFZERO;          +----
    }
    else
    { // while high
        RFcount--;
        if ( RFcount < HIGH_TO)
            RFstate = TRFreset;    // reset if too long
    }
    break;

case TRFZERO:
    if ( RFBit)
    { // rising edge detected      +----
        //                          |
        //                          +----+
        RFstate= TRFUNO;
        B[Bptr] >>= 1;             // rotate
        if ( RFcount >= 0)
        {
            B[Bptr]+=0x80;         // shift in bit
        }
        RFcount = 0;              // reset length counter

        if ( ( ++BitCount & 7) == 0)
            Bptr++;               // advance one byte
        if (BitCount == NBIT)
        {
            RFstate = TRFreset;   // finished receiving
            RFFull = TRUE;
        }
    }
    else
    { // still low
        RFcount++;
        if ( RFcount >= LOW_TO)   // too long low
        {
            RFstate = TRFSYNC;    // fall back into RFSYNC state
            Bptr = 0;              // reset pointers, while keep counting on
            BitCount = 0;
        }
    }
    break;

case TRFSYNC:
    if ( RFBit)
    { // rising edge detected      +----+          +----..
        //                          | | <-Theader-> |
        //                          +-----+
        if ( ( RFcount < SHORT_HEAD) || ( RFcount >= LONG_HEAD))
        {
            RFstate = TRFreset;
            break;                // too short/long, no header
        }
        else
        {
            RFcount =0;           // restart counter
            RFstate= TRFUNO;
        }
    }
    else
    { // still low
        RFcount++;
    }
    break;

```

AN744

```
case TRFreset:
default:
    RFstate = TRFSYNC;           // reset state machine in all other cases
    RFcount = 0;
    Bptr = 0;
    BitCount = 0;
    break;

} // switch

} // rxi

void InitReceiver()
{
    TOIF = 0;
    TOIE = 1;                    // TMR0 overflow interrupt
    GIE = 1;                     // enable interrupts
    RFstate = TRFreset;         // reset state machine in all other cases
    RFFull = 0;                 // start with buffer empty
    XTMR = 0;                   // start extended timer
}
```

APPENDIX E: TABLE C SOURCE CODE

```

// *****
// Filename: TABLE.c
// *****
// Author: Lucio Di Jasio
// Company: Microchip Technology
// Revision: Rev 1.00
// Date: 08/07/00
//
// EEPROM TABLE Management routines
// simple "linear list" management method
//
// Compiled using HiTech C compiler v.7.93
// Compiled using CCS PIC C compiler v. 2.535
// *****/
#define MAX_USER 8 // max number of TX that can be learned
#define EL_SIZE 8 // single record size in bytes

// -----
//Table structure definition:
//
// the EEPROM is filled with an array of MAX_USER user records
// starting at address 0000
// each record is EL_SIZE byte large and contains the following fields:
// EEPROM access is in 16 bit words for efficiency
//
// DatoHi DatoLo offset
// +-----+-----+
// | FCode | IDLo | 0 XF contains the function codes (buttons) used during learning
// +-----+-----+ and the top 4 bit of Serial Number
// | IDHi | IDMi | +2 IDHi IDMi IDLo contain the 24 lsb of the Serial Number
// +-----+-----+
// | HopHi | HopLo | +4 sync counter
// +-----+-----+
// | HopHi2| HopLo2| +6 second copy of sync counter for integrity checking
// +-----+-----+
//
// NOTE a function code of 0f0 (seed transmission) is considered
// invalid during learning and is used here to a mark location free
//
// -----
// FIND Routine
//
// search through the whole table the given a record whose ID match
//
// INPUT:
// IDHi, IDMi, IDLo, serial number to search
//
// OUTPUT:
// Ind address of record (if found)
// EHop sync counter value
// ETemp second copy of sync counter
// RETURN: TRUE if matching record found
//
byte Find()
{
    byte Found;
    Found = FALSE; // init to not found

    for (Ind=0; Ind < (EL_SIZE * MAX_USER); Ind+=EL_SIZE)
    {
        RDword( Ind); // read first Word
        FCode = (Dato>>8);
    }
}

```

AN744

```
// check if 1111xxxx
if ( (FCode & 0xf0) == 0xf0)
    continue; // empty

if (IDLo != (Dato & 0xff))
    continue; // fails match

RDnext(); // read next word
if ( ( (Dato & 0xff) == IDMi) && ( (Dato>>8) == IDHi))
{
    Found = TRUE; // match
    break;
}
} // for

if (Found == TRUE)
{
    RDnext(); // read HopHi/Lo
    EHop = Dato;
    RDnext(); // read HopHi2/Lo2
    ETemp= Dato;
}

return Found;
}

// -----
//INSERT Routine
//
//search through the whole table for an empty space
//
//INPUT:
// IDHi, IDMi, IDLo, serial number to insert
//
//OUTPUT:
// Ind address of empty record
//
//RETURN: FALSE if no empty space found
//
byte Insert()
{
    for (Ind=0; Ind < (EL_SIZE * MAX_USER); Ind+=EL_SIZE)
    {
        RDword(Ind); // read first Word
        FCode = (Dato>>8);
        // check if 1111xxxx
        if ( (FCode & 0xf0) == 0xf0)
            return TRUE; // insert point found
    } // for

    return FALSE; // could not find any empty slot
} // Insert

//-----
//Function IDWrite
// store IDHi,Mi,Lo + XF at current address Ind
//INPUT:
// Ind point to record + offset 0
// IDHi, IDMi, IDLo Serial Number
// XF function code
//OUTPUT:
//
byte IDWrite()
{
    if (!FLearn)
```

```

        return FALSE;          // Guard statement: check if Learn ON

    Dato = Buffer[7];
    Dato = (Dato<<8) + IDLo;
    WRword(Ind);              // write first word

    Dato = IDHi;
    Dato = (Dato<<8) + IDMi;
    WRword(Ind+2);          // write second word

    return TRUE;
} // IDWrite

//-----
//Function HopUpdate
// update sync counter of user record at current location
//INPUT:
// Ind    record + offset 0
// Hop    current sync counter
//OUTPUT:
// none
//
byte HopUpdate()
{
    if (!FHopOK)
        return FALSE;        // Guard statement: check if Hop update

    Hop = ((word)HopHi<<8) + HopLo;
    Dato = Hop;
    WRword(Ind+4);          // write at offset +4
    Dato = Hop;
    WRword(Ind+6);          // back up copy at offset +6
    FHopOK = FALSE;        // for safety disable updating hopping code

    return TRUE;
} // HopUpdate

//-----
//Function ClearMem
// mark all records free
//INPUT:
//OUTPUT:
//USES:
//
byte ClearMem()
{
    for (Ind=0; Ind < (EL_SIZE * MAX_USER); Ind+=EL_SIZE)
    {
        Dato = 0xffff;
        WRword( Ind);
    }

    return TRUE;
} // ClearMem

```

APPENDIX F: MEM-87X C SOURCE CODE

```
// *****  
// Filename: mem-87x.c  
// *****  
// Author: Lucio Di Jasio  
// Company: Microchip Technology  
// Revision: Rev 1.00  
// Date: 08/11/00  
//  
// Internal EEPROM routines for PIC16F87X  
//  
// Compiled using HiTech PIC C compiler v.7.93  
// Compiled using CCS PIC C compiler v. 2.535  
// *****  
  
void RDword(word Ind)  
{  
    Dato = EEPROM_READ( Ind);  
    Dato += (word) EEPROM_READ( Ind+1) <<8;  
}  
  
void RDnext()  
{  
    // continue reading  
    EEADR++; // NOTE generate no carry  
    Dato = ((RD=1), EEDATA);  
    EEADR++;  
    Dato += ((RD=1), EEDATA)<<8;  
}  
  
void WRword(word Ind)  
{  
    EEPROM_WRITE( Ind, Dato); GIE = 1; // write and re-enable interrupt  
    EEPROM_WRITE( Ind+1, Dato>>8); GIE = 1;  
}
```

APPENDIX G: KEY GENERATION SOURCE CODE

```
// -----
// LEGAL NOTICE
//
// The information contained in this document is proprietary and
// confidential information of Microchip Technology Inc. Therefore all
// parties are required to sign a non-disclosure agreement before
// receiving this document.
// -----
//
// Keeloq Normal Key Generation and Decryption
// Compiled using CCS PIC C compiler v. 2.535
// Compiled using HITECH PIC C compiler v. 7.93
//
// version 1.00      08/07/2000 Lucio Di Jasio
//
// =====

byte   DKEY[8];           // Decryption key
byte   SEED[4];          // seed value = serial number
word   NextHop;          // resync value for 2 Chance

#ifdef HITECH
    #include "fastdech.c" // for HITECH optimized version
#else
    #include "fastdecc.c" // for CCS optimized version
#endif

// -----
void LoadManufCode()
{
    DKEY[0]=0xef; // DKEY=0123456789ABCDEF
    DKEY[1]=0xcd;
    DKEY[2]=0xAB;
    DKEY[3]=0x89;
    DKEY[4]=0x67;
    DKEY[5]=0x45;
    DKEY[6]=0x23;
    DKEY[7]=0x01;
}

//-----
//
// Key Generation routine
//
// Normal Learn algorithm
//
// INPUT:  Serial Number (Buffer[4..7])
//         Manufacturer code
// OUTPUT: DKEY[0..7] computed decryption key
//
void NormalKeyGen()
{
    byte   HOPTemp[4]; // HOP temp buffer
    byte   SKEYTemp[4]; // temp decryption key

    // check if same Serial Number as last time while output active
    // it was stored in Seed
    if (( SEED[0] != Buffer[4]) ||
        ( SEED[1] != Buffer[5]) ||
        ( SEED[2] != Buffer[6]) ||
        ( SEED[3] != (Buffer[7] & 0x0f)) ||
```

AN744

```
(COut == 0)
{
    // no new KeyGen is needed
    memcpy( HOPtemp, Buffer, 4);    // save hopping code to temp
    memcpy( SEED, &Buffer[4], 4);  // make seed = Serial Number
    SEED[3] &= 0x0f;              // mask out function codes

    // compute LSB of decryption key first
    memcpy( Buffer, SEED, 4);      // get SEED in
    Buffer[3] |= 0x20;             // add constant 0x20
    LoadManufCode();
    Decrypt();
    memcpy( SKEYtemp, Buffer, 4);  // save result for later

    // compute MSb of decryption key
    memcpy( Buffer, SEED, 4);      // get SEED in
    Buffer[3] |= 0x60;             // add constant 0x60
    LoadManufCode();
    Decrypt();
    memcpy( &DKEY[4], Buffer, 4);  // move it into DKEY MSb
    memcpy( DKEY, SKEYtemp, 4);   // add LSB

    // ready for Decrypt
    memcpy( Buffer, HOPtemp, 4);  // restore hopping code
}
else // same Serial Number as last time...
{
    // just keep on using same Decryption Key
}

} // Normal KeyGen

//-----
//
// Valid Decryption Check
//
// INPUT:  Serial Number (Buffer[4..7])
//         Hopping Code (Buffer[0..3])
// OUTPUT: TRUE if discrimination bits == lsb Serial Number
//         and decrypted function code == plain text function code
byte DecCHK()
{
    // verify discrimination bits
    if ( DisLo != IDLo)    // compare low 8bit of Serial Number
        return FALSE;

    if ( ( (Buffer[3] ^ IDMi) & 0x3) != 0) // compare 9th and 10th bit of SN
        return FALSE;

    // verify function code
    if ( ((Buffer[3] ^ Buffer[7]) & 0xf0) != 0)
        return FALSE;

    return TRUE;
} // DecCHK

//-----
//
// Hopping Code Verification
//
// INPUT:  Hopping Code (Buffer[0..3])
//         and previous value stored in EEPROM EHOP
// OUTPUT: TRUE if hopping code is incrementing and inside a safe window (16)
//
```



```

byte ReqResync()
{
    F2Chance= TRUE;           // flag that a second (sequential) transmission
    NextHop = Hop+1;         // is needed to resynchronize receiver
    return FALSE;           // cannot accept for now
}

byte HopCHK()
{
    FHopOK = FALSE;         // Hopping Code is not verified yet
    FSame = FALSE;         // Hopping Code is not the same as previous

    // make it a 16 bit signed integer
    Hop = ((word)HopHi << 8) + HopLo;

    if ( F2Chance)
        if ( NextHop == Hop)
        {
            F2Chance = FALSE;       // resync success
            FHopOK = TRUE;
            return TRUE;
        }

    // verify EEPROM integrity
    if ( EHop != ETemp)
        return ReqResync();       // memory corrupted need a resync

    // main comparison
    ETemp = Hop - EHop;           // subtract last value from new one

    if ( ETemp < 0)               // locked region
        return FALSE;           // fail

    else if ( ETemp > 16)         // resync region
        return ReqResync();

    else                           // 0 >= ETemp > 16 ; open window
    {
        if ( ETemp == 0)         // same code (ETemp == 0)
            FSame = TRUE;       // rise a flag

        FHopOK = TRUE;
        return TRUE;
    }
} // HopCHK

```

AN744

NOTES:

“All rights reserved. Copyright © 2001, Microchip Technology Incorporated, USA. Information contained in this publication regarding device applications and the like is intended through suggestion only and may be superseded by updates. No representation or warranty is given and no liability is assumed by Microchip Technology Incorporated with respect to the accuracy or use of such information, or infringement of patents or other intellectual property rights arising from such use or otherwise. Use of Microchip’s products as critical components in life support systems is not authorized except with express written approval by Microchip. No licenses are conveyed, implicitly or otherwise, under any intellectual property rights. The Microchip logo and name are registered trademarks of Microchip Technology Inc. in the U.S.A. and other countries. All rights reserved. All other trademarks mentioned herein are the property of their respective companies. No licenses are conveyed, implicitly or otherwise, under any intellectual property rights.”

Trademarks

The Microchip name, logo, PIC, PICmicro, PICMASTER, PICSTART, PRO MATE, KEELOQ, SEEVAL, MPLAB and The Embedded Control Solutions Company are registered trademarks of Microchip Technology Incorporated in the U.S.A. and other countries.

Total Endurance, ICSP, In-Circuit Serial Programming, FilterLab, MXDEV, microID, FlexROM, fuzzyLAB, MPASM, MPLINK, MPLIB, PICDEM, ICEPIC, Migratable Memory, FanSense, ECONOMONITOR, SelectMode and microPort are trademarks of Microchip Technology Incorporated in the U.S.A.

Serialized Quick Term Programming (SQTP) is a service mark of Microchip Technology Incorporated in the U.S.A.

All other trademarks mentioned herein are property of their respective companies.

© 2001, Microchip Technology Incorporated, Printed in the U.S.A., All Rights Reserved.

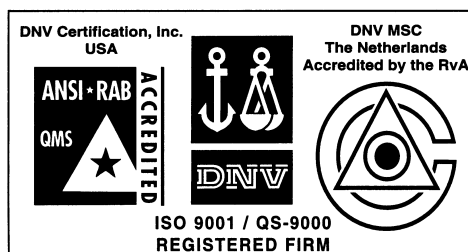

Microchip received QS-9000 quality system certification for its worldwide headquarters, design and wafer fabrication facilities in Chandler and Tempe, Arizona in July 1999. The Company's quality system processes and procedures are QS-9000 compliant for its PICmicro® 8-bit MCUs, KEELOQ® code hopping devices, Serial EEPROMs and microperipheral products. In addition, Microchip's quality system for the design and manufacture of development systems is ISO 9001 certified.



MICROCHIP

WORLDWIDE SALES AND SERVICE

AMERICAS

Corporate Office

2355 West Chandler Blvd.
Chandler, AZ 85224-6199
Tel: 480-792-7200 Fax: 480-792-7277
Technical Support: 480-792-7627
Web Address: <http://www.microchip.com>

Rocky Mountain

2355 West Chandler Blvd.
Chandler, AZ 85224-6199
Tel: 480-792-7966 Fax: 480-792-7456

Atlanta

500 Sugar Mill Road, Suite 200B
Atlanta, GA 30350
Tel: 770-640-0034 Fax: 770-640-0307

Austin

Analog Product Sales
8303 MoPac Expressway North
Suite A-201
Austin, TX 78759
Tel: 512-345-2030 Fax: 512-345-6085

Boston

2 Lan Drive, Suite 120
Westford, MA 01886
Tel: 978-692-3848 Fax: 978-692-3821

Boston

Analog Product Sales
Unit A-8-1 Millbrook Tarry Condominium
97 Lowell Road
Concord, MA 01742
Tel: 978-371-6400 Fax: 978-371-0050

Chicago

333 Pierce Road, Suite 180
Itasca, IL 60143
Tel: 630-285-0071 Fax: 630-285-0075

Dallas

4570 Westgrove Drive, Suite 160
Addison, TX 75001
Tel: 972-818-7423 Fax: 972-818-2924

Dayton

Two Prestige Place, Suite 130
Miamisburg, OH 45342
Tel: 937-291-1654 Fax: 937-291-9175

Detroit

Tri-Atria Office Building
32255 Northwestern Highway, Suite 190
Farmington Hills, MI 48334
Tel: 248-538-2250 Fax: 248-538-2260

Los Angeles

18201 Von Karman, Suite 1090
Irvine, CA 92612
Tel: 949-263-1888 Fax: 949-263-1338

Mountain View

Analog Product Sales
1300 Terra Bella Avenue
Mountain View, CA 94043-1836
Tel: 650-968-9241 Fax: 650-967-1590

New York

150 Motor Parkway, Suite 202
Hauppauge, NY 11788
Tel: 631-273-5305 Fax: 631-273-5335

San Jose

Microchip Technology Inc.
2107 North First Street, Suite 590
San Jose, CA 95131
Tel: 408-436-7950 Fax: 408-436-7955

Toronto

6285 Northam Drive, Suite 108
Mississauga, Ontario L4V 1X5, Canada
Tel: 905-673-0699 Fax: 905-673-6509

ASIA/PACIFIC

Australia

Microchip Technology Australia Pty Ltd
Suite 22, 41 Rawson Street
Epping 2121, NSW
Australia
Tel: 61-2-9868-6733 Fax: 61-2-9868-6755

China - Beijing

Microchip Technology Beijing Office
Unit 915
New China Hong Kong Manhattan Bldg.
No. 6 Chaoyangmen Beidajie
Beijing, 100027, No. China
Tel: 86-10-85282100 Fax: 86-10-85282104

China - Shanghai

Microchip Technology Shanghai Office
Room 701, Bldg. B
Far East International Plaza
No. 317 Xian Xia Road
Shanghai, 200051
Tel: 86-21-6275-5700 Fax: 86-21-6275-5060

Hong Kong

Microchip Asia Pacific
RM 2101, Tower 2, Metroplaza
223 Hing Fong Road
Kwai Fong, N.T., Hong Kong
Tel: 852-2401-1200 Fax: 852-2401-3431

India

Microchip Technology Inc.
India Liaison Office
Divyasree Chambers
1 Floor, Wing A (A3/A4)
No. 11, O'Shaughnessey Road
Bangalore, 560 025, India
Tel: 91-80-2290061 Fax: 91-80-2290062

Japan

Microchip Technology Intl. Inc.
Benex S-1 6F
3-18-20, Shinyokohama
Kohoku-Ku, Yokohama-shi
Kanagawa, 222-0033, Japan
Tel: 81-45-471-6166 Fax: 81-45-471-6122

ASIA/PACIFIC (continued)

Korea

Microchip Technology Korea
168-1, Youngbo Bldg. 3 Floor
Samsung-Dong, Kangnam-Ku
Seoul, Korea
Tel: 82-2-554-7200 Fax: 82-2-558-5934

Singapore

Microchip Technology Singapore Pte Ltd.
200 Middle Road
#07-02 Prime Centre
Singapore, 188980
Tel: 65-334-8870 Fax: 65-334-8850

Taiwan

Microchip Technology Taiwan
11F-3, No. 207
Tung Hua North Road
Taipei, 105, Taiwan
Tel: 886-2-2717-7175 Fax: 886-2-2545-0139

EUROPE

Denmark

Microchip Technology Denmark ApS
Regus Business Centre
Lautrup høj 1-3
Ballerup DK-2750 Denmark
Tel: 45 4420 9895 Fax: 45 4420 9910

France

Arizona Microchip Technology SARL
Parc d'Activite du Moulin de Massy
43 Rue du Saule Trapu
Batiment A - 1er Etage
91300 Massy, France
Tel: 33-1-69-53-63-20 Fax: 33-1-69-30-90-79

Germany

Arizona Microchip Technology GmbH
Gustav-Heinemann Ring 125
D-81739 Munich, Germany
Tel: 49-89-627-144 0 Fax: 49-89-627-144-44

Germany

Analog Product Sales
Lochhamer Strasse 13
D-82152 Martinsried, Germany
Tel: 49-89-895650-0 Fax: 49-89-895650-22

Italy

Arizona Microchip Technology SRL
Centro Direzionale Colleoni
Palazzo Taurus 1 V. Le Colleoni 1
20041 Agrate Brianza
Milan, Italy
Tel: 39-039-65791-1 Fax: 39-039-6899883

United Kingdom

Arizona Microchip Technology Ltd.
505 Eskdale Road
Winnersh Triangle
Wokingham
Berkshire, England RG41 5TU
Tel: 44 118 921 5869 Fax: 44-118 921-5820

01/30/01

All rights reserved. © 2001 Microchip Technology Incorporated. Printed in the USA. 5/01 Printed on recycled paper.

Information contained in this publication regarding device applications and the like is intended through suggestion only and may be superseded by updates. It is your responsibility to ensure that your application meets with your specifications. No representation or warranty is given and no liability is assumed by Microchip Technology Incorporated with respect to the accuracy or use of such information, or infringement of patents or other intellectual property rights arising from such use or otherwise. Use of Microchip's products as critical components in life support systems is not authorized except with express written approval by Microchip. No licenses are conveyed, implicitly or otherwise, except as maybe explicitly expressed herein, under any intellectual property rights. The Microchip logo and name are registered trademarks of Microchip Technology Inc. in the U.S.A. and other countries. All rights reserved. All other trademarks mentioned herein are the property of their respective companies.