



N-Chanel Power MOSFET

ANA2N65B, ANP2N65B, ANB2N65B,
AND2N65B, ANI2N65B, ANU2N65B
Rdson=5,0 Ω, Vds=650 V, Qg(tot)=8 nC

Applications

- SMPS
- PFC

Features

- Low Qg
- Low Rdson
- RoHS compliant

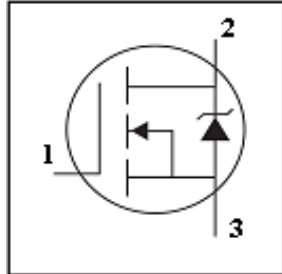

1	2	3
Gate	Drain	Source

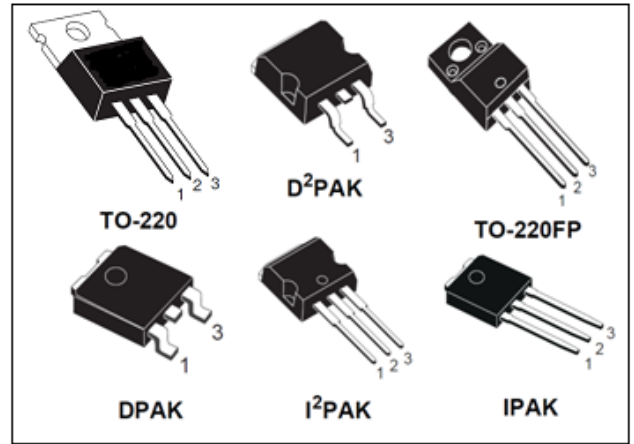

Table 1. Device summary

Part numbers	Marking	Package	Packaging
ANA2N65B	A2N65B	TO-220FP	Tube
ANP2N65B	P2N65B	TO-220	Tube
ANB2N65B	B2N65B	D ² PAK	Tape and reel
AND2N65B	D2N65B	DPAK	Tape and reel
ANI2N65B	I2N65B	I ² PAK	Tape and reel
ANU2N65B	I2N65B	IPAK	Tape and reel

Table 2. Absolute Maximum Ratings

Symbol	Parameter	Value						Units
		TO-220FP	TO-220	D ² PAK	I ² PAK	DPAK	IPAK	
I _D	Drain current (continuous), V _{GS} = at T _C = 25°C	2,0						A
I _D	Drain current (continuous), V _{GS} = at T _C = 100°C	—						A
I _{DM(1)}	Drain current (pulsed) at T _C = 25°C	8,0						A
V _{GS}	Gate-source voltage	±20						V
P _D	Maximum Power Dissipation at T _C = 25°C	23	54			44		W
	Maximum Power Dissipation at T _C = 100°C	—						W
T _{stg}	Storage temperature	-55 ... +150						°C
T _j	Operating junction temperature	-55 ... +150						
T _L	Soldering Temperature, for 10 sec.	260						
	Mounting Torque, 6-32 or M3 Screw	1,13		—				N·m

Table 3. Thermal resistance

Symbol	Parameter	Value						Value
		TO-220FP	TO-220	D ² PAK	I ² PAK	DPAK	IPAK	
R _{thj-case}	Thermal resistance junction-case max	5,5	2,32			2,87		°C/W
R _{thj-amb}	Thermal resistance junction-ambient max	62,5				50		°C/W



Table 4. Electrical Characteristics of the MOSFET

Symbol	Parameter	Min.	Typ.	Max.	Units	Conditions	Ref. Fig
Off Characteristics							
$V_{(BR)DSS}$	Drain-to-Source Breakdown Voltage	650			V	$V_{GS} = 0V, I_D = 250\mu A$	
$\Delta V_{(BR)DSS}/\Delta T_J$	Temperature Coefficient of Breakdown Voltage		0,4		V/°C	$I_D = 250\mu A$, Referenced to 25°C	
I_{DSS}	Zero Gate Voltage Drain Current			10	μA	$V_{DS} = 650V, V_{GS} = 0V$	
I_{GSS}	Gate to Body Leakage Current			± 100	nA	$V_{GS} = 30V, V_{DS} = 0V$	
On Characteristics							
$V_{GS(th)}$	Gate Threshold Voltage	2,0		4,0	V	$V_{DS} = V_{GS}, I_D = 250\mu A$	
$\Delta V_{GS(th)}/\Delta T_J$	Threshold Voltage temp. coefficient		—		mV/°C		
$R_{DS(on)}$	Static Drain to Source On Resistance			5,0	Ω	$V_{GS} = 10V, I_D = 1A$	
g_{fs}	Forward Transconductance		—		S		
Dynamic Characteristics							
C_{iss}	Input Capacitance		270		pF	$V_{DS} = 25V, V_{GS} = 0V, f = 1MHz$	
C_{oss}	Output Capacitance		40		pF		
C_{rss}	Reverse Transfer Capacitance		5		pF		
$Q_{g(tot)}$	Total Gate Charge		9,0		nC	$V_{DS} = 480V, V_{GS} = 10V, I_D = 2.4A$	
Q_{gs}	Gate to Source Gate Charge		1,6		nC		
Q_{gd}	Gate to Drain "Miller" Charge		4,3		nC		
Switching Characteristics							
$t_{d(on)}$	Turn-On Delay Time		10		ns	$V_{DD} = 300V, I_D = 2.4A, R_G = 25\Omega$	
t_r	Rise Time		25		ns		
$t_{d(off)}$	Turn-Off Delay Time		20		ns		
t_f	Fall Time		25		ns		

Table 5. Avalanche Characteristic

Symbol	Parameter	Typ.	Max.	Units	Conditions	Ref.Fig
E_{AS}	Single Pulse Avalanche Energy		140	mJ		
E_{AR}	Repetitive Avalanche Energy		4,5	mJ		
$V_{DS(Avalanche)}$	Repetitive Avalanche Voltage		—	V		
I_{AR}	Avalanche Current		2,0	A		



Table 6. Source drain diode

Symbol	Parameter	Min.	Typ.	Max.	Units	Conditions	Ref.Fig
V_{SD}	Diode Forward Voltage			1,4	V	$V_{GS} = 0\text{ V}, I_{SD} = 2.0\text{ A}$	
I_S	Continuous Source Current (Body Diode)			2,0	A		
I_{SM}	Pulsed Source Current (Body Diode)			8,0	A		
t_{rr}	Reverse Recovery Time		180		ns	$V_{GS} = 0\text{ V}, I_{SD} = 2.4\text{ A}, di/dt$	
Q_{rr}	Reverse Recovery Charge		0,72		nC	$= 100\text{ A}/\mu\text{s}$	

PRELIMINARY



TO-220FP

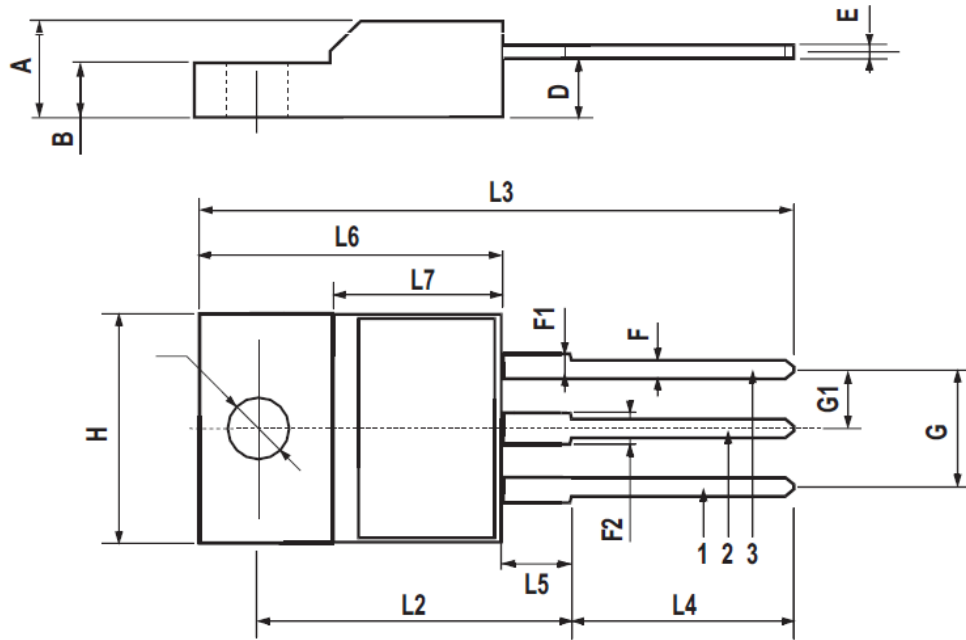

DIM.	mm.			inch		
	MIN.	TYP	MAX.	MIN.	TYP.	MAX.
A	4.4		4.6	0.173		0.181
B	2.5		2.7	0.098		0.106
D	2.5		2.75	0.098		0.108
E	0.45		0.7	0.017		0.027
F	0.75		1	0.030		0.039
F1	1.15		1.5	0.045		0.067
F2	1.15		1.5	0.045		0.067
G	4.95		5.2	0.195		0.204
G1	2.4		2.7	0.094		0.106
H	10		10.4	0.393		0.409
L2		16			0.630	
L3	28.6		30.6	1.126		1.204
L4	9.8		10.6	.0385		0.417
L5	2.9		3.6	0.114		0.141
L6	15.9		16.4	0.626		0.645
L7	9		9.3	0.354		0.366
Ø	3		3.2	0.118		0.126



TO-220

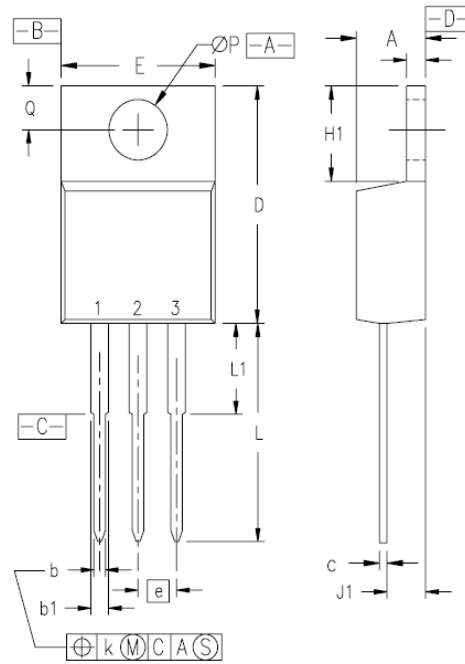

Pins: 1 - Gate 2 - Drain
 3 - Source 4 - Drain

SYM	INCHES		MILLIMETERS	
	MIN	MAX	MIN	MAX
A	.170	.190	4.32	4.83
b	.025	.040	0.64	1.02
b1	.045	.065	1.15	1.65
c	.014	.022	0.35	0.56
D	.580	.630	14.73	16.00
E	.390	.420	9.91	10.66
e	.100 BSC		2.54 BSC	
F	.045	.055	1.14	1.40
H1	.230	.270	5.85	6.85
J1	.090	.110	2.29	2.79
k	0	.015	0	0.38
L	.500	.550	12.70	13.97
L1	.110	.230	2.79	5.84
ØP	.139	.161	3.53	4.08
Q	.100	.125	2.54	3.18



D²PAK

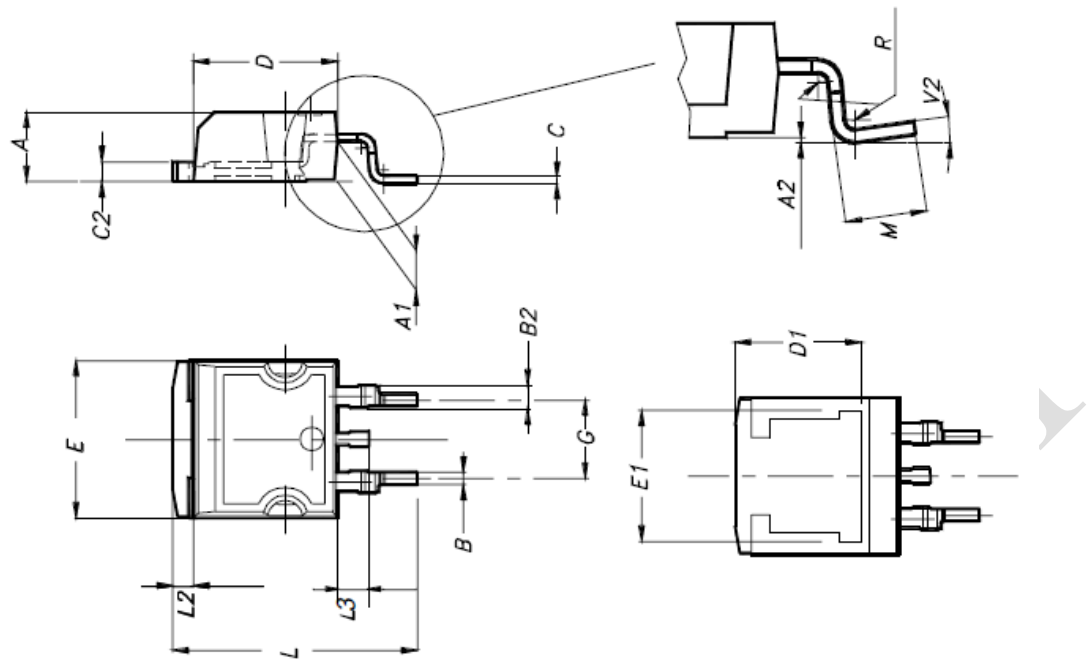

DIM.	mm.			inch		
	MIN.	TYP	MAX.	MIN.	TYP.	MAX.
A	4.4		4.6	0.173		0.181
A1	2.49		2.69	0.098		0.106
A2	0.03		0.23	0.001		0.009
B	0.7		0.93	0.027		0.036
B2	1.14		1.7	0.044		0.067
C	0.45		0.6	0.017		0.023
C2	1.23		1.36	0.048		0.053
D	8.95		9.35	0.352		0.368
D1		8			0.315	
E	10		10.4	0.393		
E1		8.5			0.334	
G	4.88		5.28	0.192		0.208
L	15		15.85	0.590		0.625
L2	1.27		1.4	0.050		0.055
L3	1.4		1.75	0.055		0.068
M	2.4		3.2	0.094		0.126
R		0.4			0.015	
V2	0°		8°			



DPAK

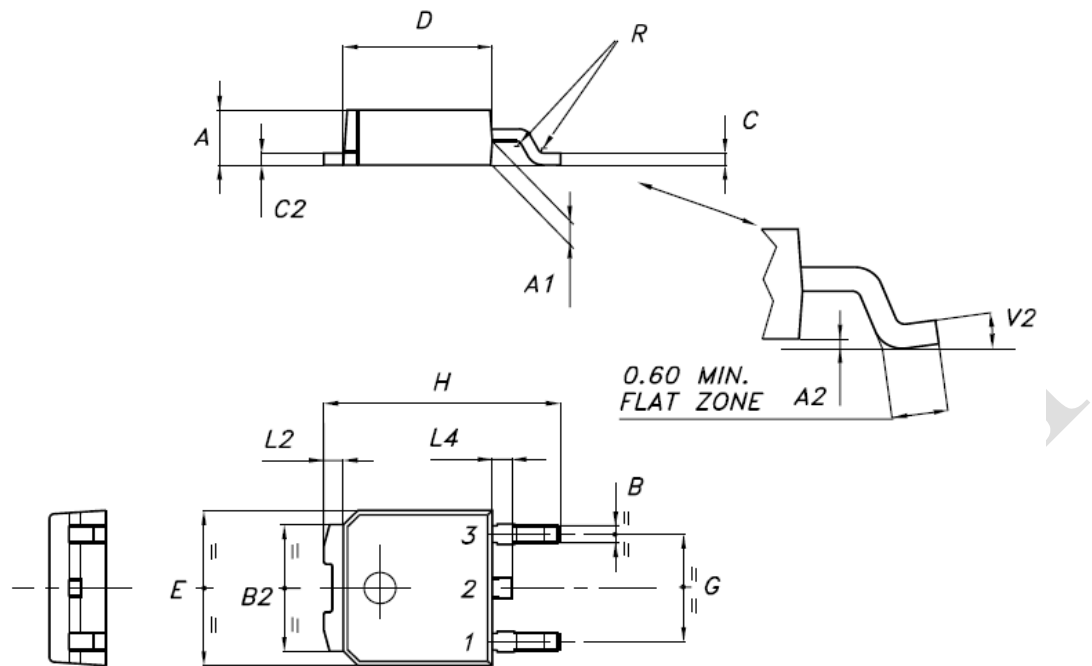

DIM.	mm			inch		
	MIN.	TYP.	MAX.	MIN.	TYP.	MAX.
A	2.20		2.40	0.087		0.094
A1	0.90		1.10	0.035		0.043
A2	0.03		0.23	0.001		0.009
B	0.64		0.90	0.025		0.035
B2	5.20		5.40	0.204		0.213
C	0.45		0.60	0.018		0.024
C2	0.48		0.60	0.019		0.024
D	6.00		6.20	0.236		0.244
E	6.40		6.60	0.252		0.260
G	4.40		4.60	0.173		0.181
H	9.35		10.10	0.368		0.398
L2		0.8			0.031	
L4	0.60		1.00	0.024		0.039
V2	0°		8°	0°		0°



I²PAK

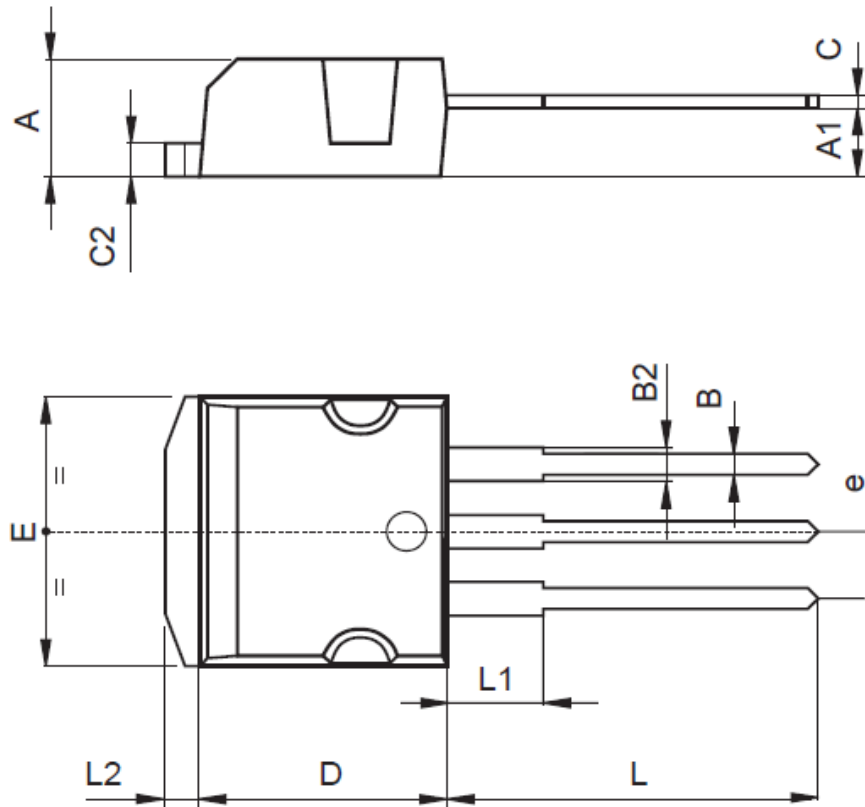

DIM.	mm			inch		
	MIN.	TYP.	MAX.	MIN.	TYP.	MAX.
A	4.4		4.6	0.173		0.181
A1	2.49		2.69	0.098		0.106
B	0.7		0.93	0.027		0.036
B2	1.14		1.7	0.044		0.067
C	0.45		0.6	0.017		0.023
C2	1.23		1.36	0.048		0.053
D	8.95		9.35	0.352		0.368
e	2.4		2.7	0.094		0.106
E	10		10.4	0.393		0.409
L	13.1		13.6	0.515		0.531
L1	3.48		3.78	0.137		0.149
L2	1.27		1.4	0.050		0.055



IPAK

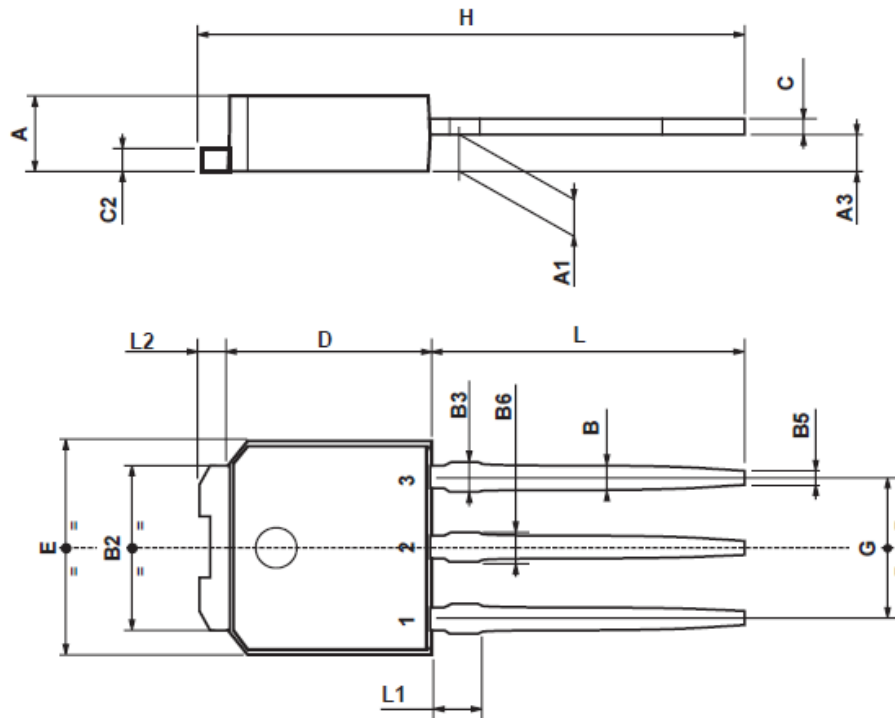

DIM.	mm			inch		
	MIN.	TYP.	MAX.	MIN.	TYP.	MAX.
A	2.2		2.4	0.086		0.094
A1	0.9		1.1	0.035		0.043
A3	0.7		1.3	0.027		0.051
B	0.64		0.9	0.025		0.031
B2	5.2		5.4	0.204		0.212
B3			0.85			0.033
B5		0.3			0.012	
B6			0.95			0.037
C	0.45		0.6	0.017		0.023
C2	0.48		0.6	0.019		0.023
D	6		6.2	0.236		0.244
E	6.4		6.6	0.252		0.260
G	4.4		4.6	0.173		0.181
H	15.9		16.3	0.626		0.641
L	9		9.4	0.354		0.370
L1	0.8		1.2	0.031		0.047
L2		0.8	1		0.031	0.039