

+ Nanophosphate[®] High Power Lithium Ion Cell ANR26650*M1-A*



KEY FEATURES AND BENEFITS

- + Excellent abuse tolerance and superior cycle life from A123's patented Nanophosphate[®] lithium ion chemistry
- + High power with over 2,200 W/kg and 4,400 W/L
- + High usable energy over a wide state of charge (SOC) range



ANR26650 Cell Specifications

Cell Dimensions (mm)	ø26 x 65
Cell Weight (g)	72
Cell Capacity (nominal/minimum, Ah)	2.3/2.2
Voltage (nominal, V)	3.3
Internal Impedance (1kHz AC typical, mΩ)	8
Recommended Standard Charge Method	3A to 3.6V CCCV, 45 min
Recommended Fast Charge Charge Current	10A to 3.6V CCCV, 15 min
Maximum Continuous Discharge (A)	70
Maximum Pulse Discharge (10 seconds, A)	120
Cycle Life at 10C Discharge, 100% DOD	>1,000 cycles
Operating Temperature	-30°C to 55°C
Storage Temperature	-40°C to 60°C

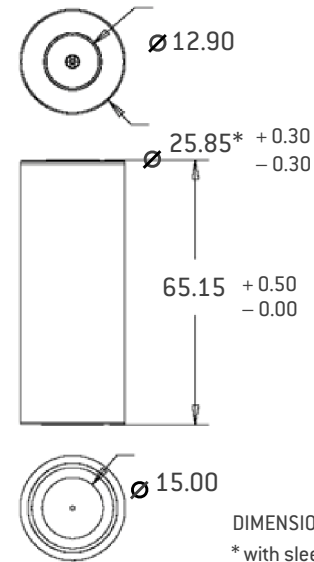

APPLICATIONS

Transportation



Advanced energy storage for electric drive vehicles

Commercial



Enabling next-generation commercial products

Electric Grid



Dynamic energy solutions for a smarter grid

+ Nanophosphate[®] High Power Lithium Ion Cell

ANR26650*M1-A*

Low Temperature Discharge Performance

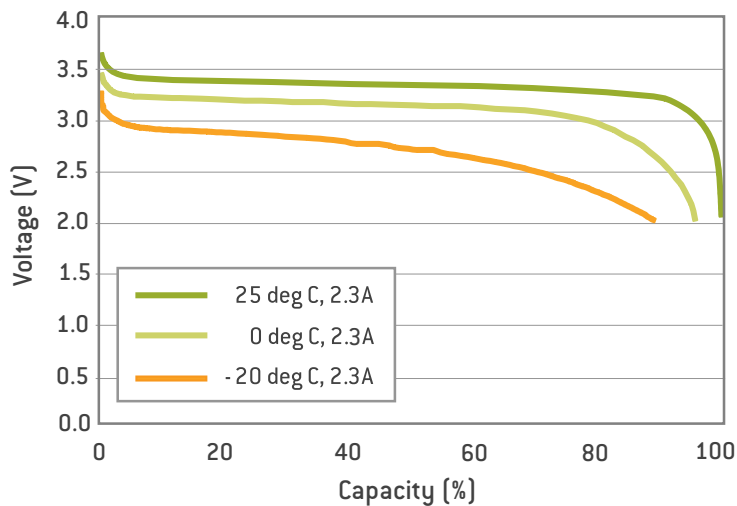

Discharge Characteristics, 25 deg C

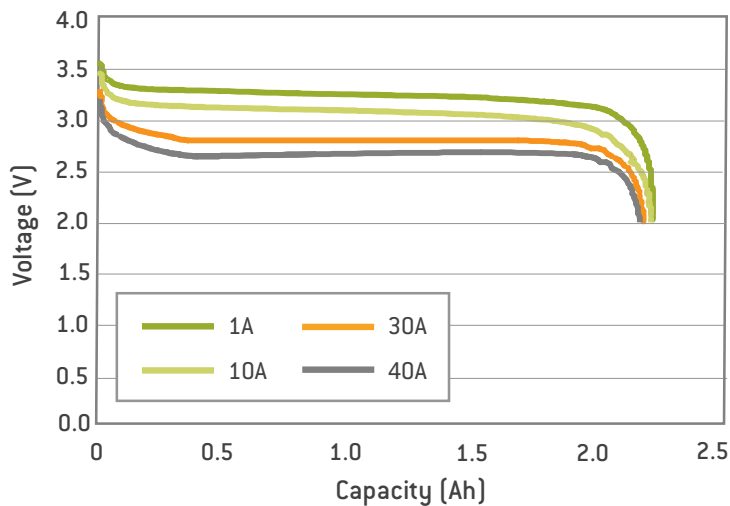

Cycle Life Performance, 100% DOD, Various Temperatures

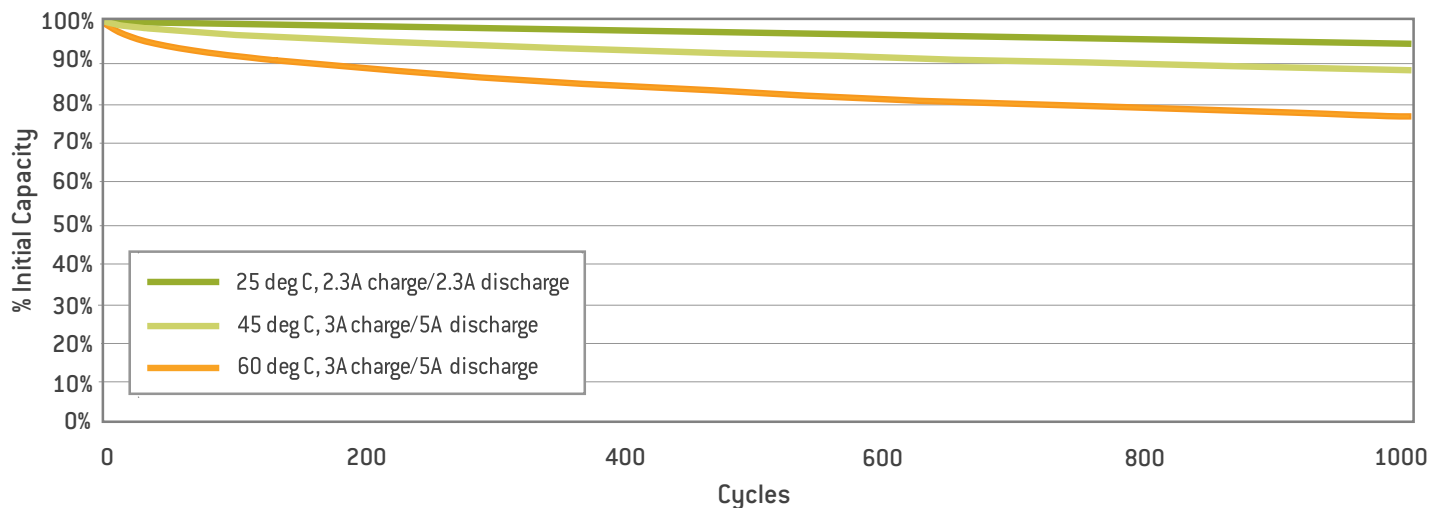

Performance may vary depending on use conditions and application.

A123 Systems makes no warranty explicit or implied with this datasheet. Contents subject to change without notice.

CORPORATE HEADQUARTERS

A123 Systems, Inc.
200 West Street
Waltham, MA 02451
(617) 778-5700

www.a123systems.com



©2011 A123 Systems, Inc. All rights reserved.
MD100001-03