



DESCRIPTION

The AO393 consist of two independent precision voltage comparators with a typical offset voltage of 1.0mV and high gain. They are specifically designed to operate from a single power supply over wide range of voltages.

Operation from split power supply is also possible and the low power supply current drain is independent of the magnitude of the power supply voltage.

The AO393 is available in SOP8 and DIP8 packages.

ORDERING INFORMATION

Package Type	Part Number	
SOP8 SPQ: 4,000pcs/Reel	M8	AO393M8R
		AO393M8VR
DIP8 SPQ: 20pcs/Tube	P8	AO393P8U
		AO393M8VU
Note	V: Halogen free Package R: Tape & Reel U: Tube	
AiT provides all RoHS products		

FEATURES

- Wide Supply Voltage Range
- Single Supply: 2.0V to 36V
- Dual Supplies: $\pm 1.0V$ to $\pm 18V$
- Low Supply Current Drain: 0.6mA
- Low Input Bias Current: 25nA (Typical)
- Low Input Offset Current: $\pm 5.0nA$ (Typical)
- Low Input Offset Voltage: 1.0mV (Typical)
- Input Common Mode Voltage Range Includes Ground
- Differential Input Voltage Range Equals to the Power Supply Voltage
- Low Output Saturation Voltage: 200mV at 4mA
- Open Collector Output
- Available in SOP8 and DIP8 packages

APPLICATION

- Vacuum Robot
- Single Phase UPS
- Server PSU
- Cordless Power Tool
- Wireless Infrastructure
- Building Automation
- Factory Automation & Control
- Motor Dives
- Infotainment & Cluster
- Battery Charger
- DC-DC Module
- PC Motherboard
- Communication Equipment

TYPICAL APPLICATION

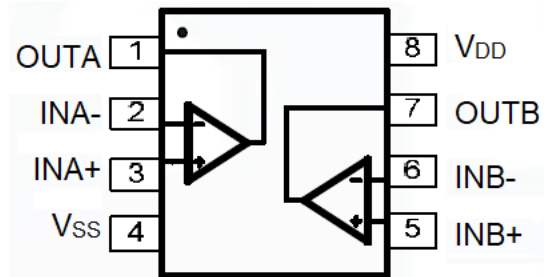

SOP8/DIP8



PIN DESCRIPTION

<p style="text-align: center;">Top View</p>		<p style="text-align: center;">Top View</p>	
SOP8	DIP8	Symbol	Function
1	1	OUTA	Output A
2	2	INA-	Analog Inverting Input A
3	3	INA+	Analog Positive Input A
4	4	V _{SS}	Ground or Negative Power Supply Input
5	5	INB+	Analog Positive Input B
6	6	INB-	Analog Inverting Input B
7	7	OUTB	Output B
8	8	V _{DD}	Positive Power Supply Input



ABSOLUTE MAXIMUM RATINGS

V _{CC} , Power Supply Voltage	±20V or 40V
V _{I(DIFF)} , Differential input voltage	40V
V _I , Input Voltage	-0.3V ~ 40V
T _{opr} , Operating Temperature Range	-25°C ~ 125°C
T _{STG} , Storage Temperature Range	-65°C ~ 150°C

Stress beyond above listed "Absolute Maximum Ratings" may lead permanent damage to the device. These are stress ratings only and operations of the device at these or any other conditions beyond those indicated in the operational sections of the specifications are not implied. Exposure to absolute maximum rating conditions for extended periods may affect device reliability.

NOTE1: This input current will only exist when the voltage at any of the input leads is driven negative. It is due to the collector-base junction of the input PNP transistors becoming forward biased and thereby acting as input diode clamps. In addition to this diode action, there is also lateral NPN parasitic transistor action on the IC chip. This transistor action can cause the output voltages of the comparators to go to the V₊ voltage level (or to ground for a large overdrive) for the time duration that an input is driven negative. This is not destructive and normal output states will re-establish when the input voltage, which was negative, again returns to a value greater than -0.3 V_{DC} at 25°C).

RECOMMENDED OPERATING CONDITIONS

Parameter	Symbol	Conditions	Min	Typ	Max	Unit
Supply Voltage	V _{CC}		2	-	36	V
Operating Temperature Range	T _A		-40	-	85	°C



ELECTRICAL CHARACTERISTICS

Limits in standard typeface are for $T_A=25^\circ\text{C}$, bold typeface applies over $T_A=-40^\circ\text{C}$ to 85°C ^{NOTE2}, $V_{CC}=5\text{V}$, $\text{GND}=0\text{V}$, unless otherwise specified.

Parameter	Conditions		Min	Typ	Max	Unit
Input Offset Voltage	$V_O=1.4\text{V}$, $R_S=0\Omega$, $V_{CC}=5\text{V}$ to 30V		-	1.0	3.0	mV
			-	-	5	
Input Bias Current	I_{IN+} or I_{IN-} with output in Linear Range, $V_{CM}=0\text{V}$		-	25	250	nA
			-	-	400	
Input Offset Current	$I_{IN+} - I_{IN-}$, $V_{CM}=0\text{V}$		-	5.0	50	nA
			-	-	200	
Input Common-Mode Voltage Range ^{NOTE3}	$V_{CC} = 30\text{V}$		0	-	$V_{CC}-1.5$	V
Supply Current	$R_L=\infty$	$V_{CC} = 5\text{V}$	-	0.6	1.0	mA
			-	-	2	
		$V_{CC} = 30\text{V}$	-	0.7	1.7	
			-	-	3	
Voltage Gain	$V_{CC}=15\text{V}$, $R_L \geq 15\text{k}\Omega$, $V_O=1\text{V}$ to 11V		50	200	-	V/mV
Large Signal Response Time	$V_{IN}=\text{TTL Logic Swing}$, $V_{REF}=1.4\text{V}$, $V_{RL}=5\text{V}$, $R_L=5.1\text{k}$		-	200	-	ns
Response Time	$V_{RL}=5\text{V}$, $R_L=5.1\text{k}$		-	1.3	-	μs
Output Sink Current	$V_{IN}=1\text{V}$, $V_{IN+}=0$, $V_O=1.5\text{V}$		6.0	16	-	mA
Output Leakage Current	$V_{IN}=0\text{V}$, $V_{IN+}=0$, $V_O=1.5\text{V}$		-	0.1	-	nA
	$V_{IN}=0\text{V}$, $V_{IN+}=0$, $V_O=30\text{V}$		-	-	1	μA
Saturation Voltage	$V_{IN}=1\text{V}$, $V_{IN+}=0$, $I_{SINK} \leq 4\text{mA}$		-	200	400	mV
			-	-	500	
Thermal Resistance (Junction to Case)	DIP8		-	93	-	$^\circ\text{C/W}$
	SOP8		-	138	-	

NOTE2: These specifications are limited to $-40^\circ\text{C} \leq T_A \leq 85^\circ\text{C}$. Limits over temperature are guaranteed by design, but not tested in production.

NOTE3: The input common-mode voltage of either input signal voltage should not be allowed to go negatively by more than 0.3V (at 25°C). The upper end of the common-mode voltage range is $V_{CC}-1.5\text{V}$ (at 25°C), but either or both inputs can go to $+36\text{V}$ without damages, independent of the magnitude of the V_{CC} .



TYPICAL PERFORMANCE CHARACTERISTICS

1. Supply Voltage vs. Supply Current

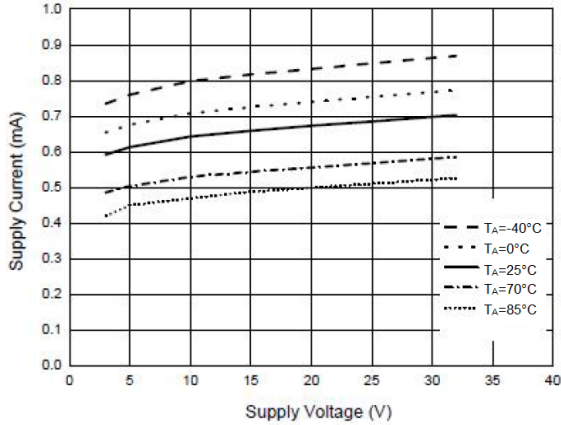

2. Supply Voltage vs. Input Bias Current

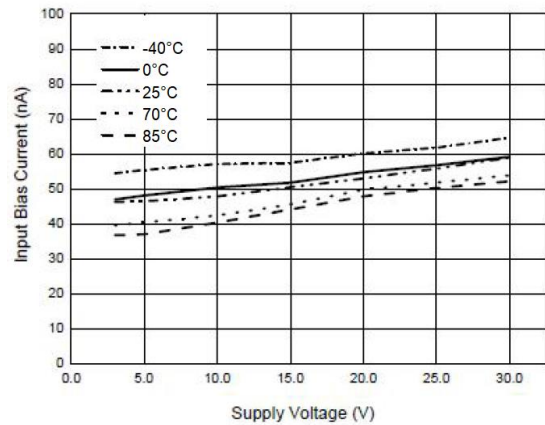

3. Output Sink Current vs. Saturation Voltage

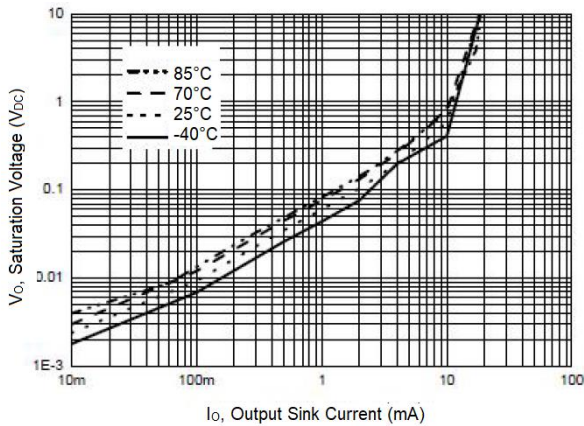

4. Response Time for 5mV Input Overdrive Negative Transition

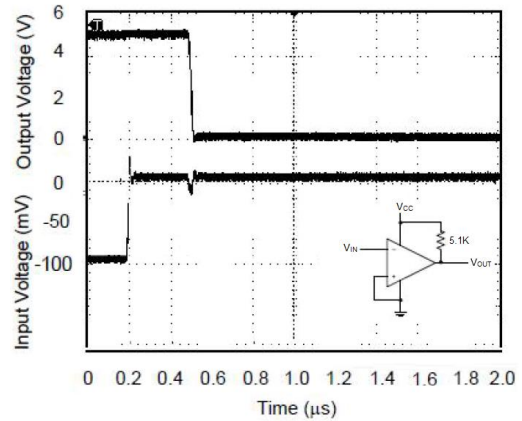

5. Response Time for 5mV Input Overdrive Positive Transition

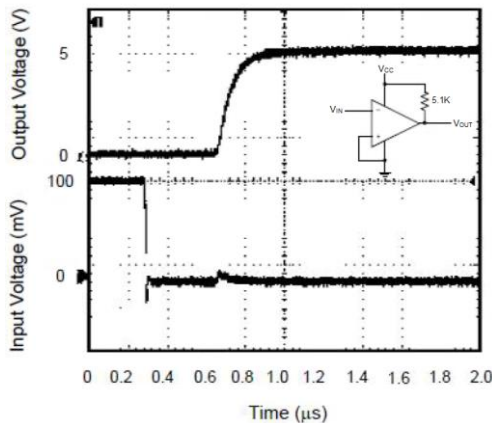



TYPICAL APPLICATIONS

1. Basic Comparator

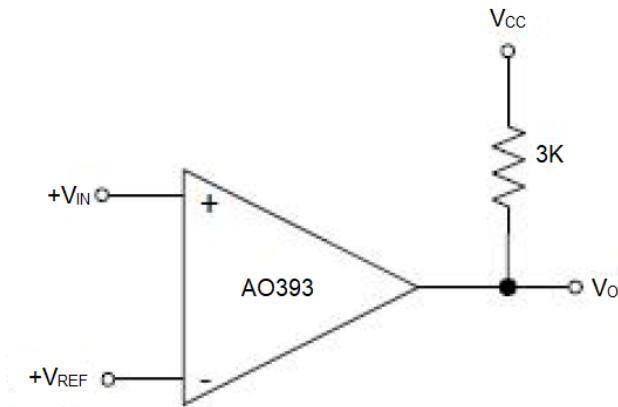

2. Driving CMOS

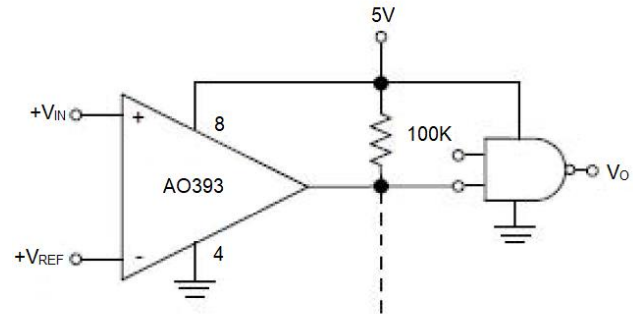

3. One Shot Multi-vibrator

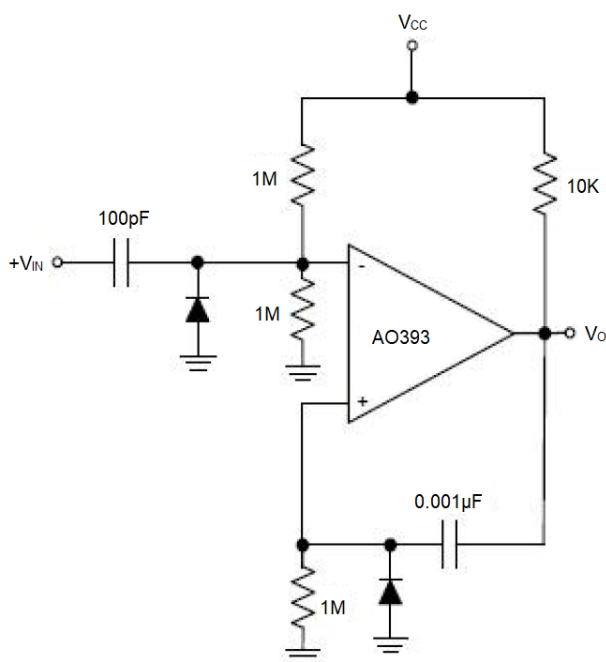

4. Square wave Oscillator

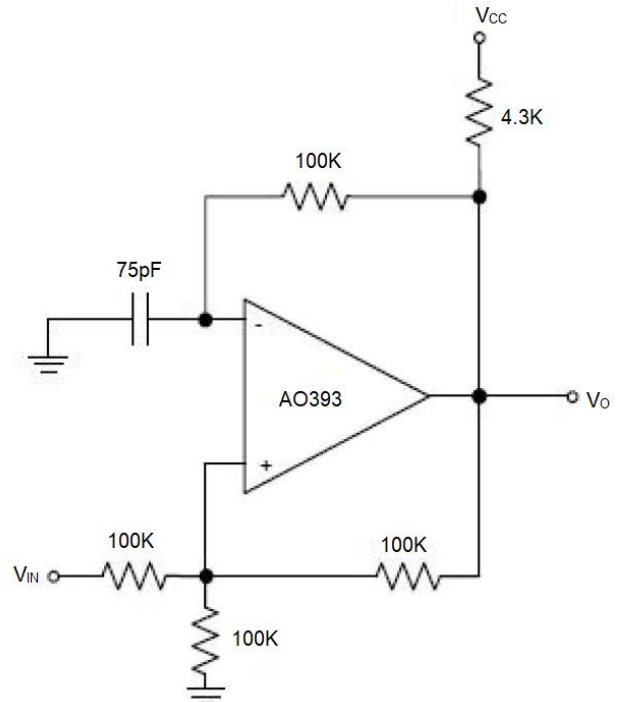



BLOCK DIAGRAM

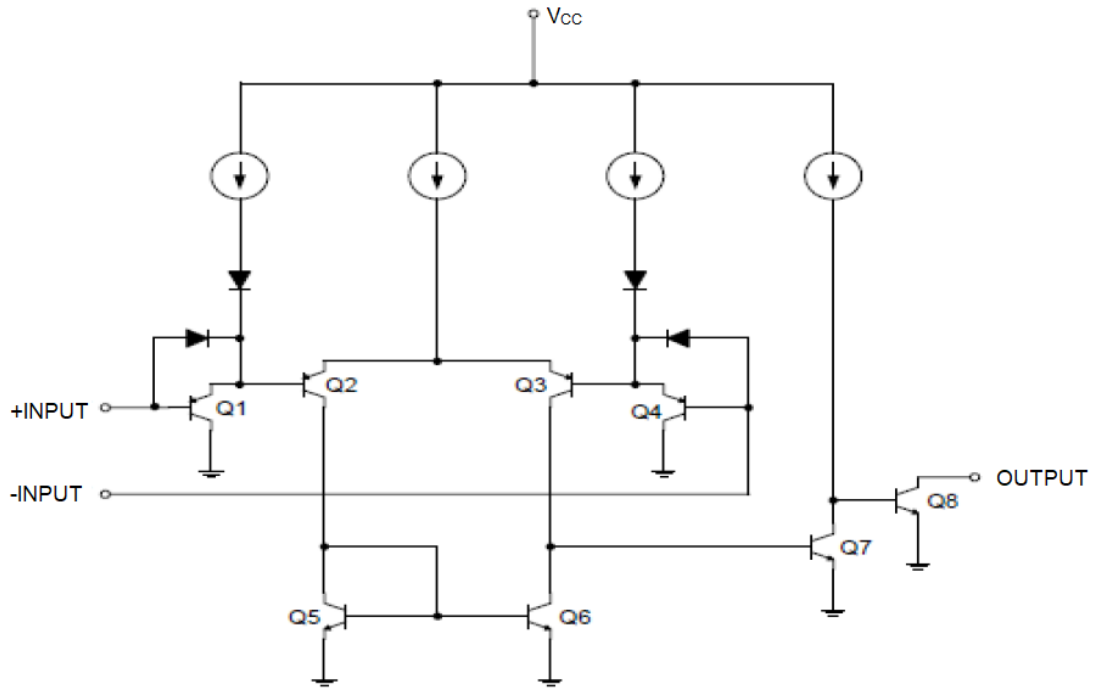



PACKAGE INFORMATION

Dimension in SOP8 (Unit: mm)

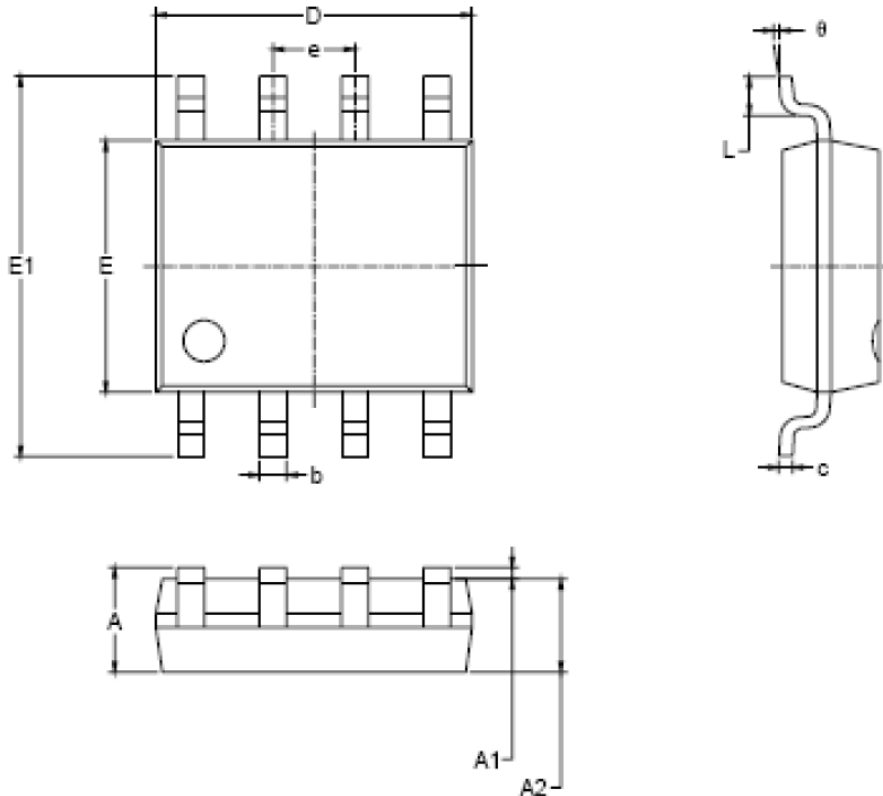

Symbol	Millimeters		Inches	
	Min.	Max.	Min.	Max.
A	1.350	1.750	0.053	0.069
A1	0.100	0.250	0.004	0.010
A2	1.350	1.550	0.053	0.061
b	0.330	0.510	0.013	0.020
c	0.170	0.250	0.006	0.010
D	4.700	5.100	0.185	0.200
E	3.800	4.000	0.150	0.157
E1	5.800	6.200	0.228	0.244
e	1.270 BSC		0.050 BSC	
L	0.400	1.270	0.016	0.050
θ	0°	8°	0°	8°



Dimension in DIP8 (Unit: mm)

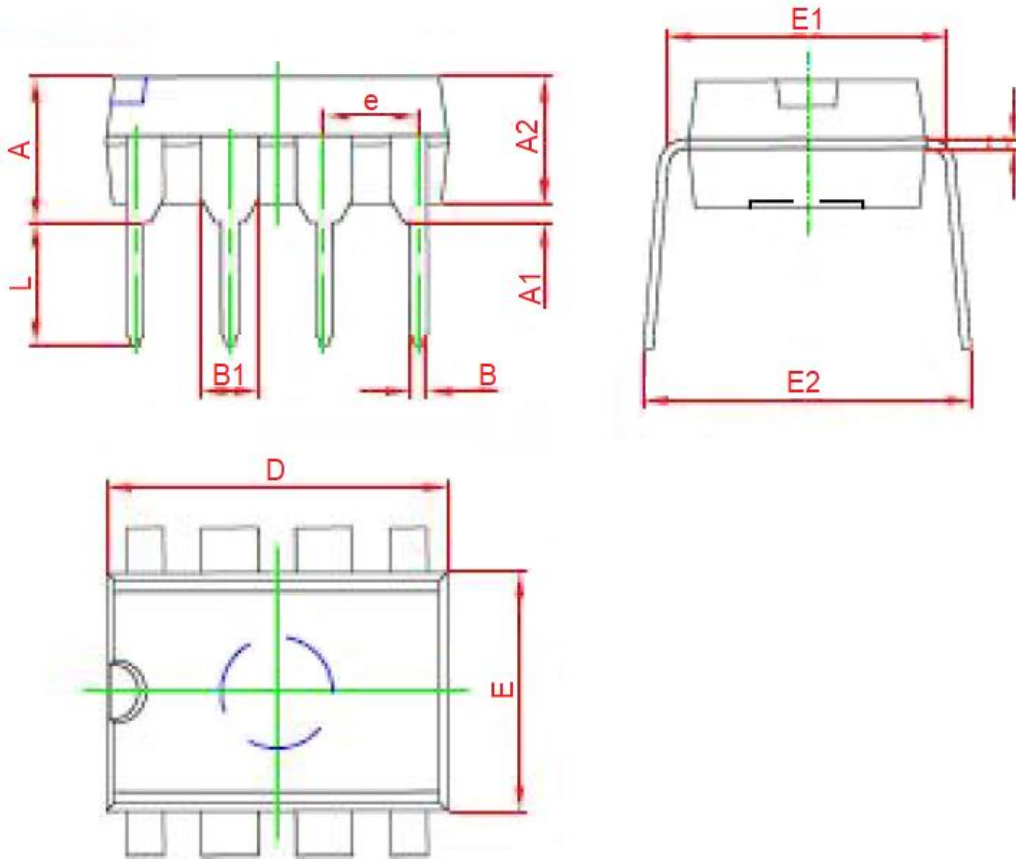

Symbol	Millimeters		Inches	
	Min.	Max.	Min.	Max.
A	3.710	4.310	0.146	0.170
A1	0.510	-	0.020	-
A2	3.200	3.600	0.126	0.142
B	0.380	0.570	0.015	0.022
B1	1.524 BSC		0.060 BSC	
C	0.204	0.360	0.008	0.014
D	9.000	9.400	0.354	0.370
E	6.200	6.600	0.244	0.260
E1	7.320	7.920	0.288	0.312
e	2.540 BSC		0.100 BSC	
L	3.000	3.600	0.118	0.142
E2	8.400	9.000	0.331	0.354



IMPORTANT NOTICE

AiT Semiconductor Inc. (AiT) reserves the right to make changes to any its product, specifications, to discontinue any integrated circuit product or service without notice, and advises its customers to obtain the latest version of relevant information to verify, before placing orders, that the information being relied on is current.

AiT Semiconductor Inc.'s integrated circuit products are not designed, intended, authorized, or warranted to be suitable for use in life support applications, devices or systems or other critical applications. Use of AiT products in such applications is understood to be fully at the risk of the customer. As used herein may involve potential risks of death, personal injury, or severe property, or environmental damage. In order to minimize risks associated with the customer's applications, the customer should provide adequate design and operating safeguards.

AiT Semiconductor Inc. assumes to no liability to customer product design or application support. AiT warrants the performance of its products of the specifications applicable at the time of sale.