

General Description

The AOZ1950 is a high-efficiency boost regulator with internal 60V MOSFET and input protection switch. The part is designed to drive up to twelve white LEDs in series. The AOZ1950 supports two dimming control methods: analog dimming and PWM dimming. In analog dimming mode, the LED current can be linearly adjusted for $\pm 12\%$ with a DC voltage on DIM pin. In PWM dimming mode, the LEDs can be turned on and off by toggling EN pin with a square wave, and the brightness is proportional to the duty cycle of the control signal. AOZ1950 is a fixed OFF pulse regulator with adaptive pulse width as a function of input and output voltage. Typical switching frequency is 800kHz. This allows the use of low-profile inductor and capacitors. The AOZ1950 works from a 2.7V to 5.5V input voltage range supporting a wide range of applications. Other features include cycle-by-cycle current limit, Input voltage short circuit protection switch, open-LED over-voltage protection, input under-voltage lockout, thermal shutdown and soft-start.

The AOZ1950 is available in a tiny 3mm x 3mm 10-pin DFN package and is rated over a -40°C to $+85^{\circ}\text{C}$ operating temperature range.

Features

- 2.7V to 5.5V input voltage range
- 60V/350m Ω internal N-channel MOSFET
- Drives up to 12 White LEDs
- 800kHz typical switching frequency with adaptive pulse width control
- 150ns nominal OFF pulse
- 300mV feedback regulation
- Analog dimming via DIM pin
- PWM dimming via EN pin
- Cycle-by-cycle current limit
- Short circuit protection switch
- Open LED over-voltage protection
- Thermal shutdown protection
- Internal soft-start
- Small 3mm x 3mm DFN package

Applications

- Portable DVD Players
- GPS Systems
- Smart Phones
- Sub Notebook PC



Typical Application

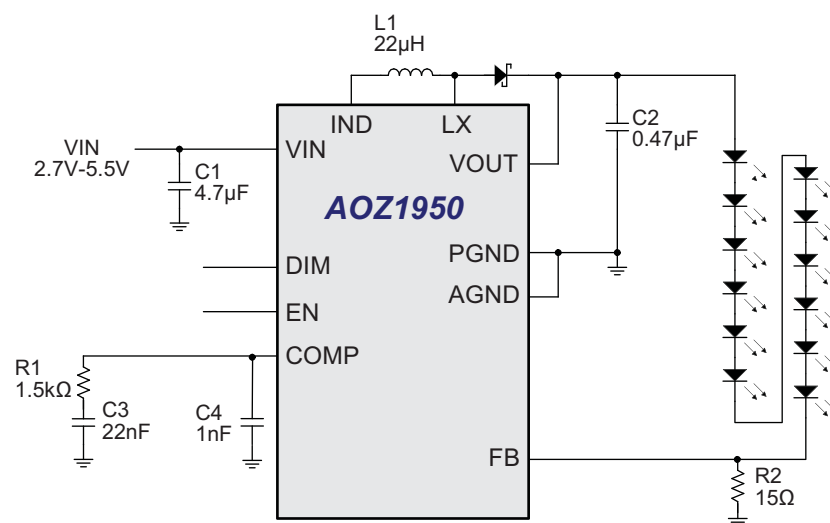

Ordering Information

| Part Number | Ambient Temperature Range | Package | Environmental |
|-------------|---------------------------|--------------|---------------------------------|
| AOZ1950DI | -40°C to +85°C | 3 x 3 DFN-10 | Green Product RoHS Compliant |



AOS Green Products use reduced levels of Halogens, and are also RoHS compliant.

Please visit www.aosmd.com/web/quality/rohs_compliant.jsp for additional information.

Pin Configuration

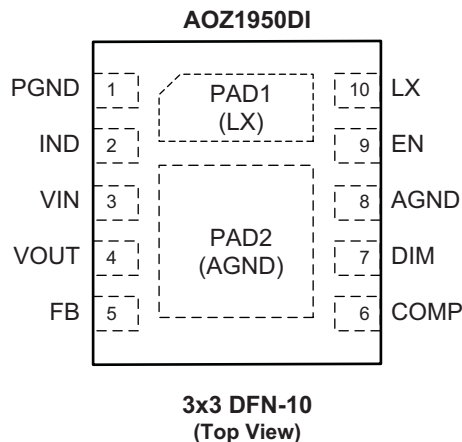

Pin Description

| Number | Name | Description |
|--------|------|---|
| 1 | PGND | Power Ground. |
| 2 | IND | Top load switch. Connect to inductor. |
| 3 | VIN | Input voltage. |
| 4 | VOUT | Output voltage. |
| 5 | FB | LED Current Feedback Input. The FB voltage is regulated at 300mV in normal operation. The FB sense resistor sets the nominal LED current. |
| 6 | COMP | Compensation pin. Typically connected to RC filter network. |
| 7 | DIM | Analog Brightness Control Input. DIM controls the LED brightness by adjusting the LED current in proportion to DIM voltage. The input range of DIM is between 250mV to 750mV, for -12% and +12% adjustment respectively. When DIM voltage is connected to VIN, the LED current is 100% of the normal setting. |
| 8 | AGND | Controller Ground. |
| 9 | EN | Enable Input. Pull EN high to enable the LED driver output and pull EN low to disable the LED driver output. The user can use EN pin for PWM dimming. The input frequency range of EN is between 200Hz and 1kHz. |
| 10 | LX | Boost Regulator Switching Node. |
| PAD1 | LX | Boost Regulator Switching Node. |
| PAD2 | AGND | Controller Ground. |

Absolute Maximum Rating

Exceeding the Absolute Maximum Ratings may damage the device

| Parameter | Rating |
|---------------------------------------|-----------------------|
| V _{IN} to AGND | -0.3V to +6V |
| LX, V _{OUT} to AGND | -0.3V to +60V |
| DIM, EN, FB, COMP, IND | V _{IN} +0.3V |
| PGND to AGND | -0.3V to +0.3V |
| Storage Temperature (T _S) | -65°C to +150°C |
| ESD Rating ⁽¹⁾ | 2kV |

Note:

- Devices are inherently ESD sensitive, handling precautions are required. Human body model rating: 1.5kΩ in series with 100pF.

Maximum Operating Ratings

The device is not guaranteed to operate beyond the Maximum Operating Ratings.

| Parameter | Rating |
|--|----------------|
| Supply Voltage (V _{IN}) | 2.7V to 5.5V |
| Ambient Temperature (T _A) | -40°C to +85°C |
| Package Thermal Resistance 3x3 DFN-10 (Θ _{JA}) | 40°C/W |

Electrical Characteristics

T_A = 25°C, V_{IN} = 3.3V, unless otherwise specified.

| Symbol | Parameter | Condition | Min. | Typ. | Max. | Units |
|-----------------------|-----------------------------------|--|------|------|------|-------|
| V _{VIN} | V _{IN} Supply Voltage | | 2.7 | | 5.5 | V |
| V _{VIN_UVLO} | V _{IN} UVLO Threshold | V _{IN} rising | | | 2.6 | V |
| V _{VIN_HYS} | V _{IN} UVLO Hysteresis | | | 200 | | mV |
| I _{VIN_ON} | V _{IN} Quiescent Current | EN = V _{IN} | | | 1.5 | mA |
| I _{VIN_OFF} | V _{IN} Shutdown Current | EN = GND | | | 1 | μA |
| V _{FB} | FB Regulation Voltage | EN = V _{IN} | 285 | 300 | 315 | mV |
| I _{FB} | FB Input Bias Current | FB = 250mV | | | 200 | nA |
| T _{OFF} | OFF Pulse Time | V _{IN} = 4.2V, V _{OUT} = 30V | | 150 | | ns |
| T _{SS} | Soft-Start Time | Number of LEDs = 6 | | 2 | | ms |
| POWER SWITCH | | | | | | |
| R _{NMOS_ON} | NMOS On Resistance | EN = V _{IN} , I _{NMOS} = 500mA | | 0.35 | 0.55 | Ω |
| I _{NMOS_OFF} | NMOS Leakage Current | EN = GND, LX = 60V | | | 2 | μA |
| R _{PMOS_ON} | PMOS On Resistance | EN = V _{IN} , I _{PMOS} = 500mA | | 0.45 | 0.65 | Ω |
| PROTECTIONS | | | | | | |
| I _{LIM} | Current Limit | | 0.75 | 1.1 | 1.35 | A |
| V _{VOUT_OVP} | OVP Threshold | V _{OUT} Rising | 49 | 53 | 57 | V |
| V _{VOUT_HYS} | OVP Threshold Hysteresis | | | 4 | | V |
| T _{SD} | Thermal Shutdown Threshold | Temperature Rising | | 145 | | °C |
| T _{SD_HYS} | Thermal Shutdown Hysteresis | | | 35 | | °C |
| LOGIC INPUTS | | | | | | |
| V _{EN_HIGH} | EN Logic High Threshold | Enable Rising | 1.5 | | | V |
| V _{EN_LOW} | EN Logic Low Threshold | | | | 0.4 | V |
| F _{PWM_DIM} | PWM Dimming Frequency Range | | 0.2 | | 1 | kHz |

Functional Block Diagram

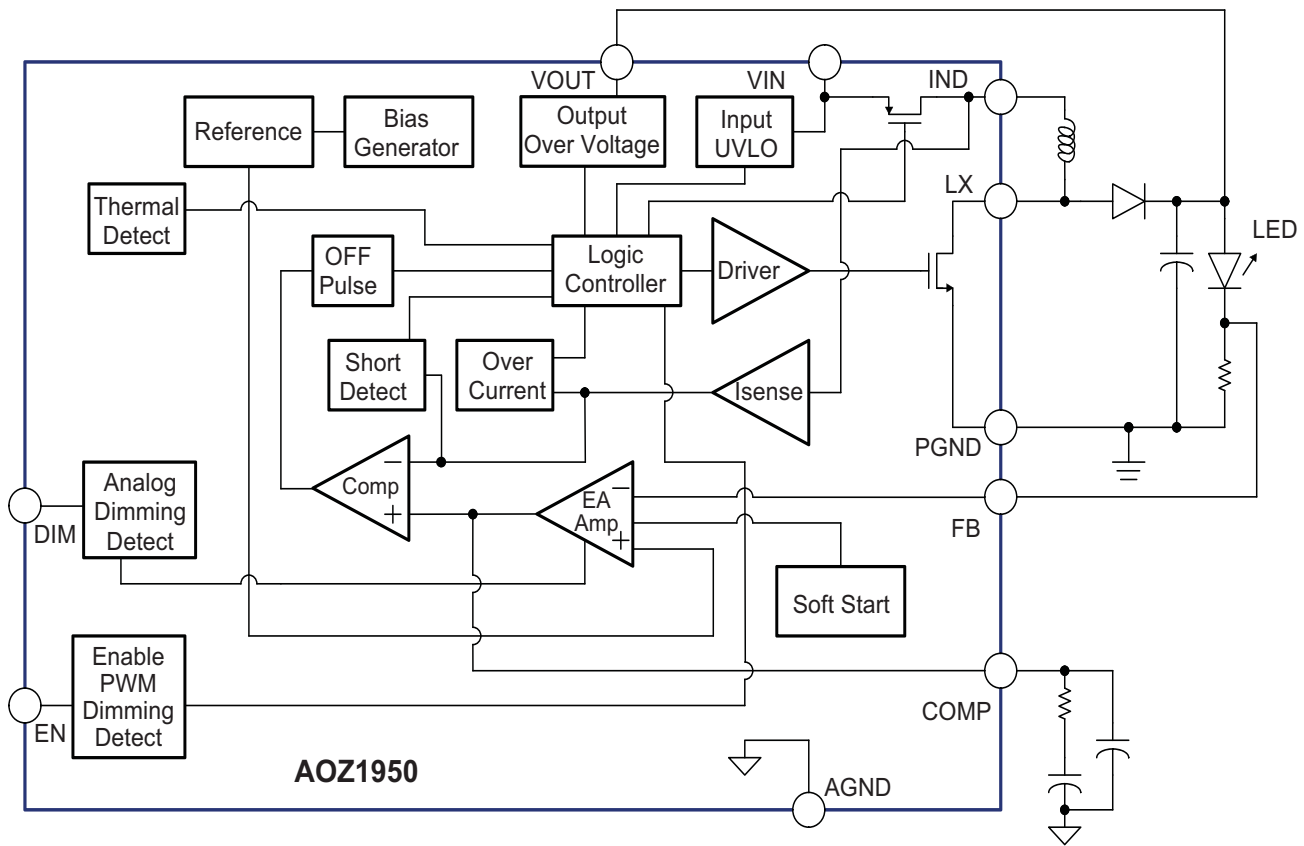

Figure 1. Functional Block Diagram

Functional Description

AOZ1950 is a constant off time boost converter that is ideal for white LED backlight applications. The operating input voltage range is from 2.7V to 5.5V and can support up to 12 in series LED's, with the maximum allowed output voltage set at 53V. The LED current is set by a series feedback resistor, located at the bottom of the LED string. The feedback voltage of the controller is set at 300mV for minimum power loss. AOZ1950 features two dimming control modes, analog and digital dimming. In analog dimming, fine adjustment of $\pm 12\%$ of the LED current can be achieved. In PWM digital dimming, a logic level pulse width is used to set the output LED current. The duty cycle of the PWM is proportionally to the LED current. In this dimming mode, the PWM frequency is set between from 200Hz to 1kHz with duty cycle from 10% to 100%.

Adaptive Constant Pulse Width Control

In a typical constant off time controller, the switching frequency changes with duty cycle. The duty cycle relationship of the boost converter entails that if either the input voltage decreases or the output voltage increases, the (1-D) off time will decrease. AOZ1950 features an adaptive constant off-time control that senses the input and output voltage while maintaining a constant switching frequency of 800 kHz. In a typical LED application of 5.5V input and 40V output (12 LEDs), the off pulse width will be approximately 150ns.

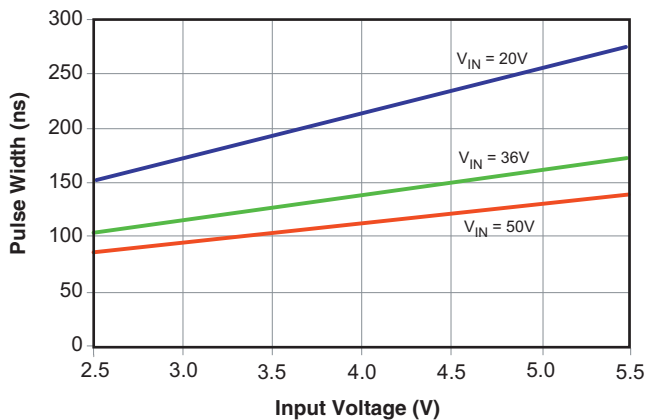

Figure 2. Pulse Width vs. Input Voltage

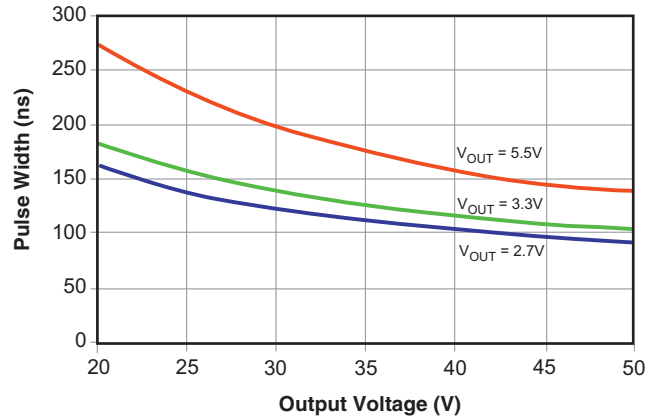

Figure 3. Pulse Width vs. Output Voltage

Over Current Protection

Under normal operation, cycle by cycle over-current protection will limit the input peak inductor current from increasing beyond 1.1A nominally.

Output Short Protection

When an output to ground short is detected, a secondary short circuit protection current level of 1.3A is activated. During this event the PMOS input protection switch along with the output boost switch are disabled simultaneously and the AOZ1950 will shutdown. The system will restart with a power cycle when either VIN or EN are toggled.

Over Voltage Protection

An over-voltage protection scheme monitors the output voltage and limits the maximum transient to 53V. The voltage rating is defined for the maximum voltage stress of the Mosfet, output boost diode, and output capacitors.

Thermal Protection

Thermal protection will be activated when the die junction temperature reaches 145°C. The system will automatically restart and lower the junction temperature to 110°C.

LED Brightness and Analog Dimming

Applying a voltage between 250mV and 750mV at the DIM pin will enable analog dimming control for adjustment of the output LED current. If no adjustment is required, the DIM pin can be connected to VIN as default. The percentage of adjustment is set to -12% on the low end for 250mV and +12% adjustment is obtained when 750mV is applied to the DIM (Figure 4).

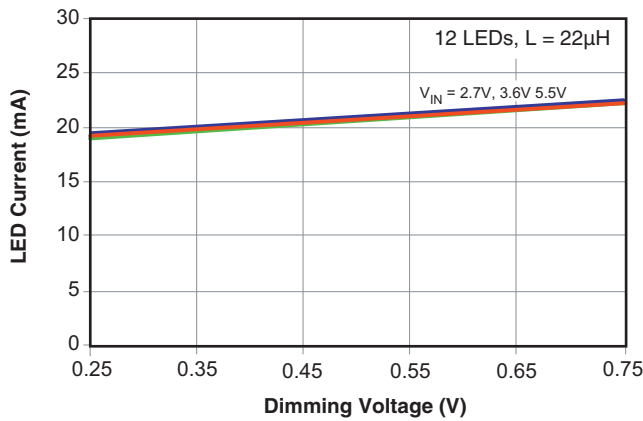

Figure 4. Analog Dimming I_{LED} vs. Dimming Voltage

LED Brightness and Digital Dimming

Digital dimming provides wider range of LED current adjustment compared to the analog dimming state. Forcing a digital PWM signal to the EN pin will activate the system to enter digital dimming mode. The output boost switch will be completely shutoff when the PWM is at logic low state and it will switch on when the PWM is at logic high. The external PWM frequency ranges between 200Hz and 1kHz. In this mode, the output LED current is averaged based on the duty cycle of the PWM signal.

For example, if the output LED current is set to 30mA at 100% duty ratio, it will be about 3mA with a duty ratio of 10%. AOZ1950 provides an extremely linear relationship between 10% to 100% (Figure 5). To accommodate both PWM both dimming and EN functions with the same pin, a delay disable of 4.5ms is used to differentiate the events of PWM dimming OFF period and shutdown of the chip. The figure below (Figure 6) shows the logic between the two different modes.

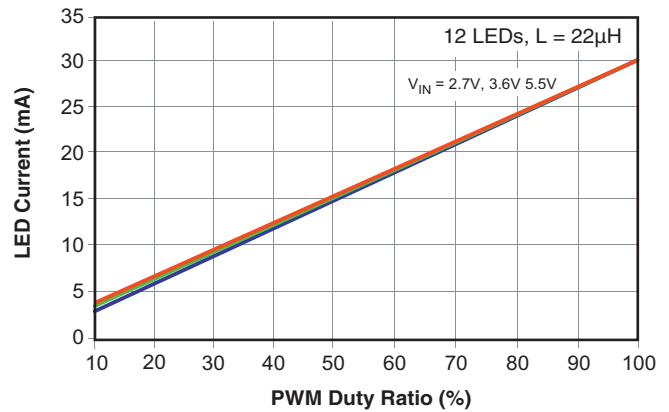

Figure 5. Digital Dimming Characteristics

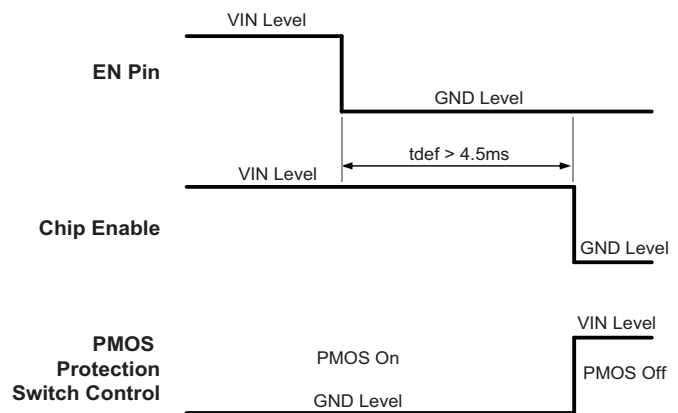

Figure 6. Logic Sequence Differentiating Dimming Mode and EN Shutdown

Typical Switching Waveforms

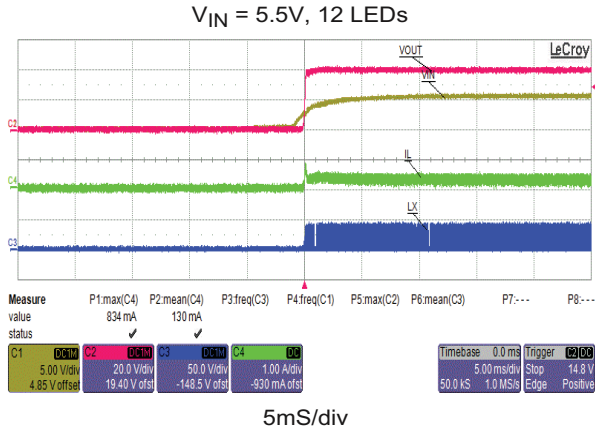

Figure 7. Startup Switching Waveforms

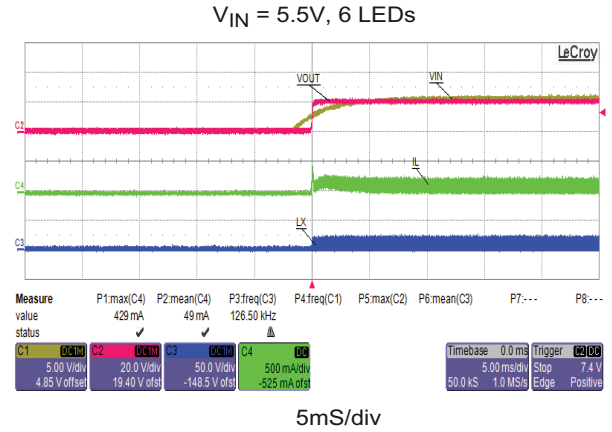

Figure 8. Startup Switching Waveforms

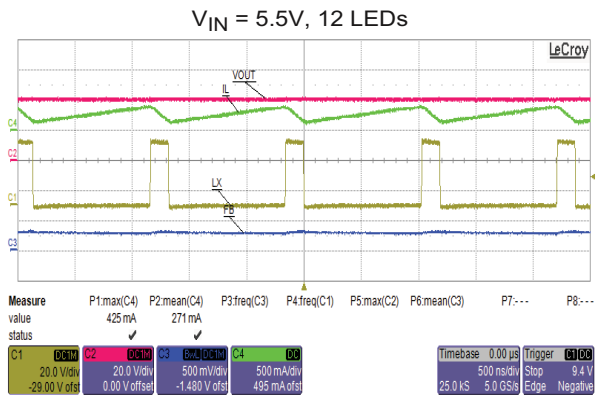

Figure 9. Steady State Waveforms

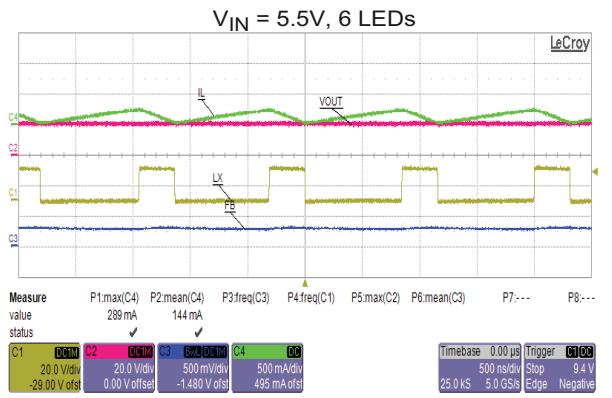

Figure 10. Steady State Waveforms

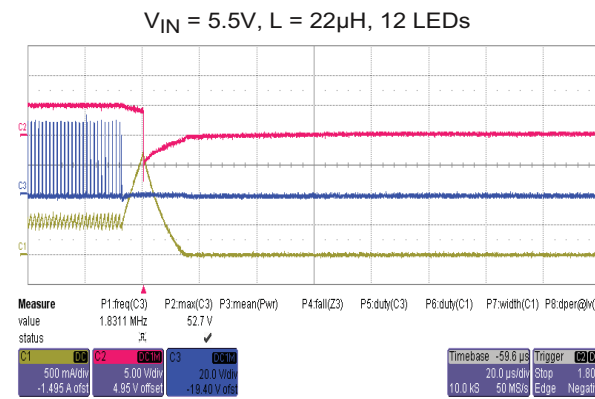

Figure 11. Output Short to GND Protection

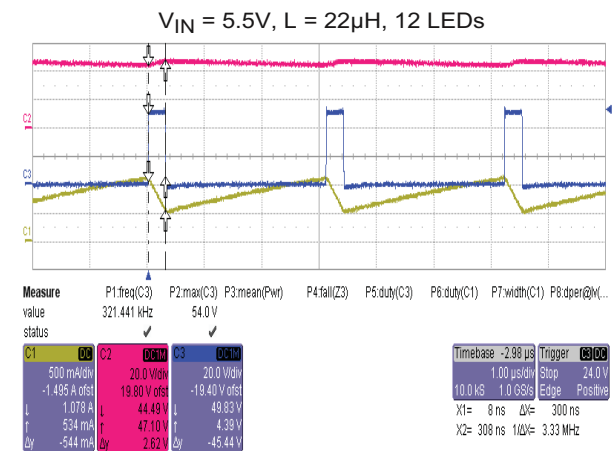

Figure 12. Current Limit Off Pulse

Digital Dimming Characteristics

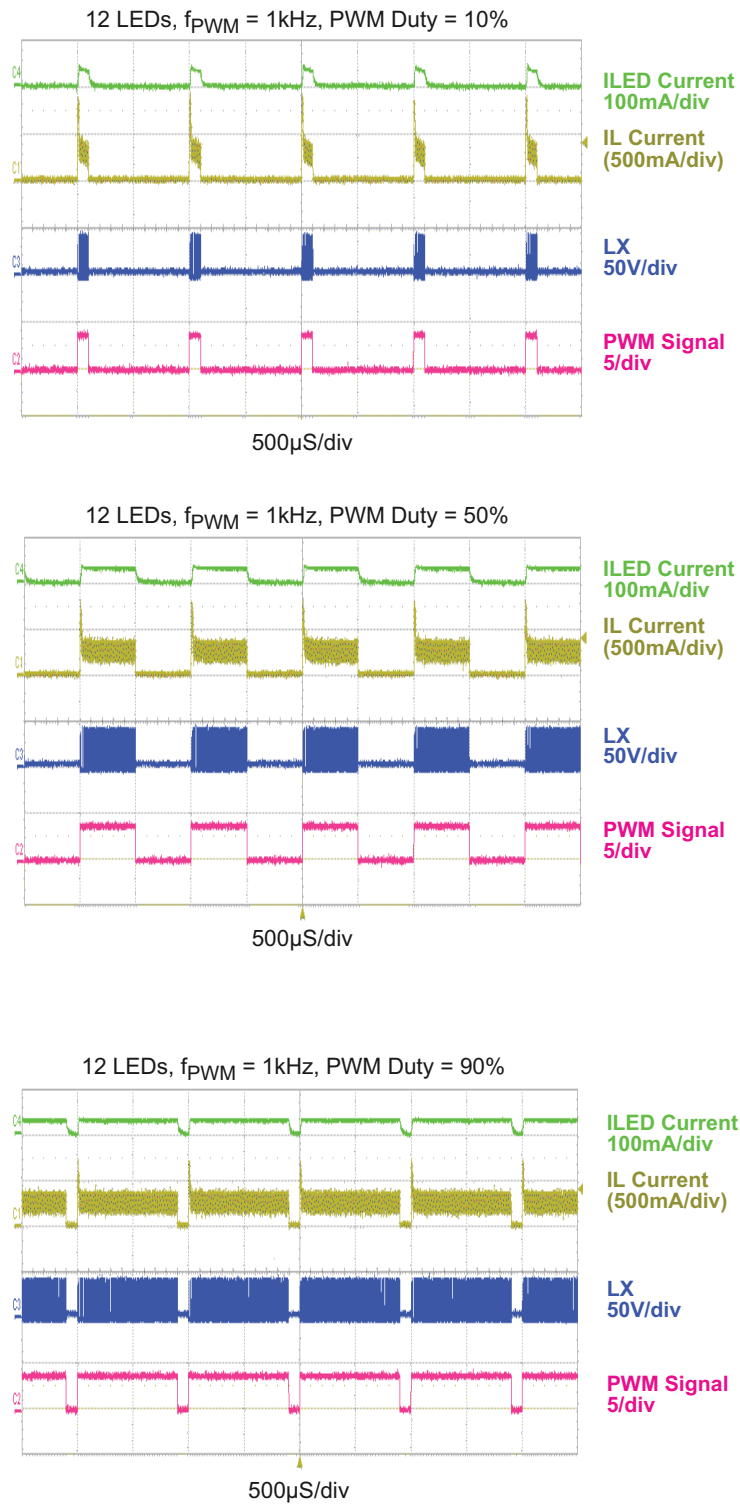

Figure 13. Digital Dimming Switching Waveforms for PWM Duty Ratio

Application Information

An example of the AOZ1950 application circuit is shown on page 1. The description below details the component selection.

LED Current Setting

The feedback voltage (FB) is set to 300mV. The total output LED current is set by a current sense resistor in series with the LED string. RSET can be calculated using EQ.1

$$I_{LED} = \frac{V_{FB}}{R_{SET}} \quad (\text{Eq. 1})$$

| R _{SET} (Ω) | I _{LED} (mA) |
|----------------------|-----------------------|
| 60 | 5 |
| 30 | 10 |
| 20 | 15 |
| 15 | 20 |
| 12 | 25 |
| 10 | 30 |

Input Capacitor

The input capacitor is connected to VIN and GND pins of the AOZ1950 to filter and maintain a steady input DC voltage. The voltage rating of input capacitor must be greater than maximum input voltage plus ripple voltage. The RMS current rating should be greater than the inductor ripple current:

The input capacitor value should be 4.7μF or higher for normal operation. The capacitor can be electrolytic, tantalum or ceramic. The input capacitor should be placed as close as possible to the IC; if not possible, a 0.1μF decoupling ceramic capacitor between VIN pin and GND in close proximity.

Inductor

The inductor is used to supply higher output voltage when the NMOS switch is off. For a given input and output voltage, the inductance and switching frequency determine the inductor ripple current, defined as,

$$I_{Lripples} = \frac{V_{OUT} - V_{IN}}{L} \times T_{OFFPULSE} \quad (\text{Eq. 2})$$

The peak inductor current is:

$$I_{Lpeak} = I_{IN} + \frac{\Delta I_L}{2} \quad (\text{Eq. 3})$$

Higher boost inductance will yield lower inductor ripple current but this will require an inductor with higher saturation current rating at the highest operating temperature. Lower ripple current helps to reduce inductor core losses. It also reduces RMS current through inductor, switch and freewheeling diode, which results in less conduction loss. The peak to peak ripple current of the inductor should be between 30% to 50% of input current. An inductor value of 22μH is recommended for 6 to 12 LED operation.

Output Capacitor

The output ripple voltage specification is key in the selection of the output capacitor. In a boost converter, the output ripple voltage is determined by load current, input voltage, output voltage, switching frequency, output capacitor value and ESR. It can be calculated by the equation below: The voltage rating of the output capacitor must be higher than the intended output boost voltage plus the output ripple voltage. Therefore some de-rating is required for ensure long term reliability.

$$\Delta V_O = I_{LED} \times \left(\frac{V_O}{V_{IN}} \times ESR_{CO} + \frac{\left(1 - \frac{V_{IN}}{V_{OUT}}\right)}{f \times C_{OUT}} \right) \quad (\text{Eq. 4})$$

$$f = \frac{V_{IN}}{V_{OUT} \times t_{OFF}} \quad (\text{Eq. 5})$$

where,

I_{LED} is the load current or LED current,
C_{OUT} is output capacitor value and
ESR_{CO} is the Equivalent Series Resistor of output capacitor.

When low ESR ceramic output capacitors are used, the impedance of the capacitor at the switching frequency dominates. Output ripple is mainly caused by capacitor value and load current with the frequency, input and output voltage. The output ripple voltage calculation can be simplified to:

$$\Delta V_O = I_L \times \frac{\left(1 - \frac{V_{IN}}{V_{OUT}}\right)}{f \times C_{OUT}} \quad (\text{Eq. 6})$$

An output capacitor with the value in the range of 2.2μF to 4.7μF is usually sufficient to meet most applications requirements.

Output Boost Diode

A low forward drop Schottky with fast transit time should be selected to improve converter efficiency.

Its current rating should be higher than the peak current that commutates during its conduction interval. In addition, the rated breakdown voltage should be higher than the application boost voltage plus some margin of transient overshoot.

Loop Compensation

AOZ1950 employs constant off time control and does not require slope compensation. The right half plane zero that is often problematic in all most boost converters has no significant effect in the AOZ1950's frequency response. The RHP zero has the effect of a zero in the gain causing +20dB/decade on the roll off, but has the effect of a pole in the phase, subtracting 90° in the phase. The RHP zero can cause instability issues if the bandwidth is higher, therefore it is recommended to lower the bandwidth by one half frequency of the RHP zero.

The RHPZ can be calculated as follows:

$$f_{RHPZ} = \frac{D_P(I_{LOAD})^2 \times R_{OUT}(I_{LOAD})}{2\pi \times L} \quad (\text{Eq. 7})$$

where,

$$D_P(I_{LOAD}) = 1 - D(I_{LOAD}) \quad (\text{Eq. 8})$$

$$R_{OUT}(I_{LOAD}) = \frac{V_{OUT}(I_{LOAD})}{I_{LOAD}} \quad (\text{Eq. 9})$$

The cross over frequency in typical applications should be a fifth of the frequency of the RHPZ location

$$f_{CROSS} = \frac{f_{RHPZ}}{5} \quad (\text{Eq. 10})$$

The objective of compensation is to shape the gain and phase of the converter's closed loop transfer function ultimately to achieve stability. The compensation pin of AOZ1950 is serves as the output of the voltage transconductance error amplifier. In a typical application, a series capacitor and resistor network connected to the COMP pin creates the pole-zero compensation network enabling a very stable high-bandwidth control loop.

The closed loop transfer function

$$H(w) = \frac{G_M \times R_{EA} \times \left(1 + \frac{s(w)}{w_Z}\right)}{\left(1 + \frac{s(w)}{w_{P1}}\right)} \quad (\text{Eq. 11})$$

The corresponding pole is:

$$f_{P1} = \frac{1}{2\pi \times R_{EA} \times C_{COMP}} \quad (\text{Eq. 12})$$

The corresponding zero is:

$$f_Z = \frac{1}{\frac{R_{COMP} \times R_{EA}}{R_{COMP} + R_{EA}} \times C_{COMP}} \quad (\text{Eq. 13})$$

where,

G_M is the error amplifier transconductance, which is $150 \cdot 10^{-6} \text{ A/V}$,

$R_{EA} = 1\text{M}\Omega$,

C_{COMP} is compensation capacitor,

R_{COMP} is compensation capacitor

A compensation resistor and capacitor value of 1.5kΩ and a 22nF along with a filter capacitor of 1nF from COMP to GND is recommended for a typical 12 LED application.

Circuit Layout and Thermal management

To minimize unwanted noise and voltage transients, careful PCB layout must be exercised to reduce the main current loop areas. This optimization helps to reduce the switching noise associated with current commutation in the circuit and also helps to improve the efficiency of the converter. In addition to reducing the main power loops it is also important to keep sensitive nodes such as compensation and enable pins in quieter ground areas away from the main power ground connection.

In the AOZ1950 boost LED driver circuit, there are two main switching loops that pulsate current flow when the NMOS turns on and off. The first loop starts when the NMOS switches on, the input current or inductor current ramps positively through the inductor and NMOS device. During this interval, the output boost diode is reversed biased with its anode pulled low to ground. Since the NMOS is internal in the AOZ1950 much of the parasitic inductance is made from the power return to the ground connection of the input capacitors.

Based on the duty cycle arrangement, the controller will signal the internal driver to turn-off the NMOS to initiate the fixed off time. After the NMOS is fully off, the continuous inductor current continues to freewheel through the output boost diode. The key parasitics in this

loop consist of PBC trace inductance from the anode to the LX connection and lastly the connection from cathode to power ground return. Both input and output capacitors should be ceramic in type to achieve low ESR and ESL specifications.

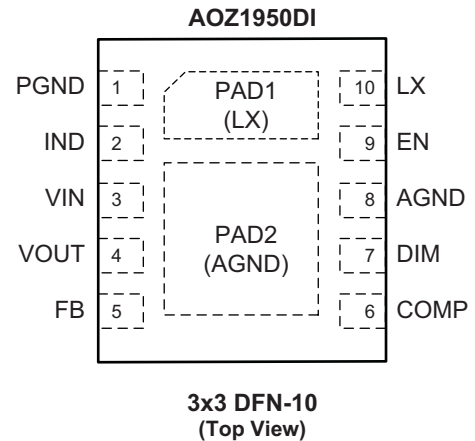
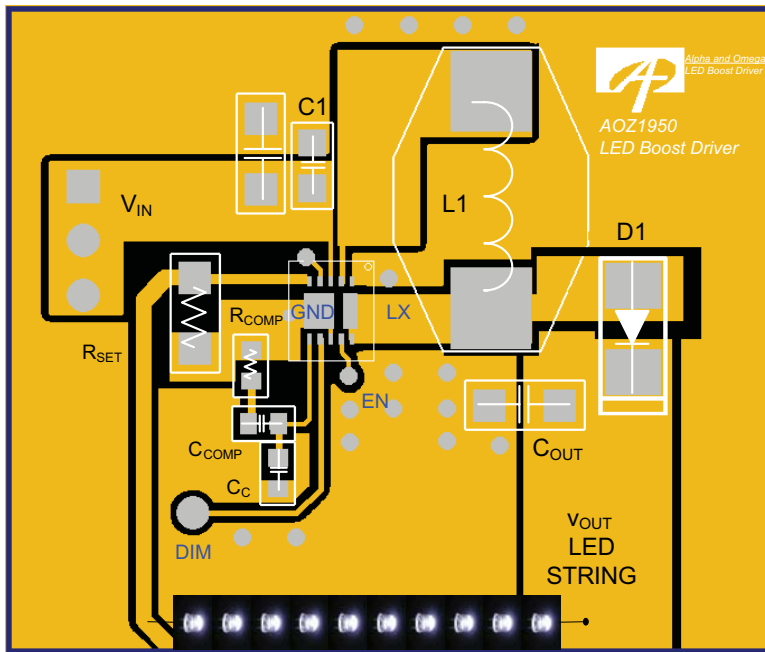

Figure 14. Example of AOZ1950 PCB Layout and DFN-10 Pin-out

Below are some key tips in minimize the two main switching loops and improving noise immunity

1. Maximized the copper area to the GND pin and the VIN pin for improved thermal dissipation.
2. Incorporate a ground plane on both top and bottom layers if possible.
3. To minimize trace inductance connects the device to the LX pin with a short wire and adoption of this technique for connections to the output capacitor and ground.
4. Add thermal vias for the GND pad for improved thermal dissipation between top and bottom layers.
5. To maximize thermal dissipation pour incorporate copper planes in unused areas.
6. Route sensitive signals such as FB and COMP pins a far distance away from the LX switching node and pin.

In the AOZ1950 boost regulator circuit, the three major power dissipating components are the AOZ1950 and output inductor. The total power dissipation of converter circuit can be measured by difference between the input and output power.

$$P_{total_loss} = (V_{IN} \times I_{IN}) - (V_O \times I_O) \quad (\text{Eq. 14})$$

The power dissipation of inductor can be approximately calculated by input current and DCR of inductor.

$$P_{inductor_loss} = I_{IN}^2 \times R_{inductor} \times 1.1 \quad (\text{Eq. 15})$$

The actual AOZ1950 junction temperature can be calculated with power dissipation and the thermal impedance from junction to ambient.

$$T_{junction} = (P_{total_loss} - P_{inductor_loss}) \times \Theta + T_{amb} \quad (\text{Eq. 15})$$

The maximum junction temperature of AOZ1950 is rated at 145°C The thermal performance of the AOZ1950 is strongly affected by the PCB layout and proper care should be taken to ensure that the device will operate under the recommended environmental conditions.

Package Dimensions, DFN3X3 10L EP2

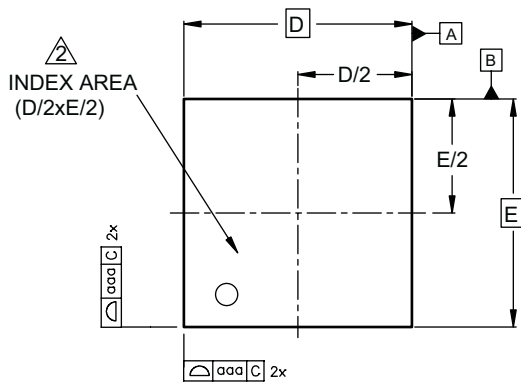

TOP VIEW

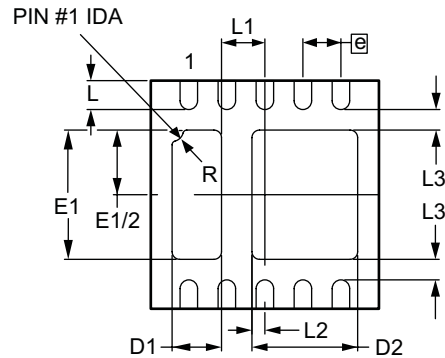

BOTTOM VIEW

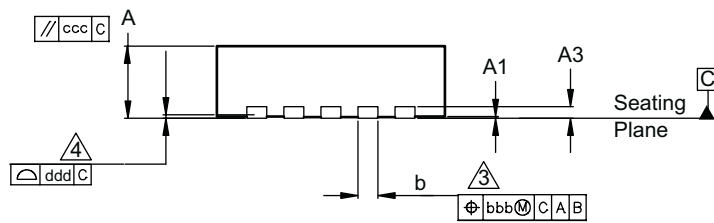

SIDE VIEW

RECOMMENDED LAND PATTERN

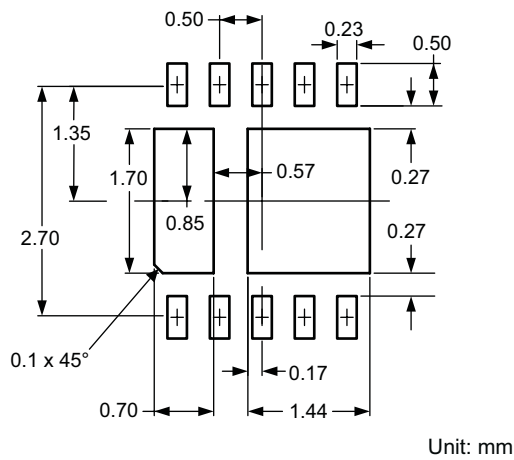

Unit: mm

Dimensions in millimeters

| Symbols | Min. | Nom. | Max. |
|---------|-----------|------|------|
| A | 0.80 | 0.90 | 1.00 |
| A1 | 0.00 | 0.02 | 0.05 |
| A3 | 0.20 REF | | |
| b | 0.20 | 0.23 | 0.33 |
| D | 3.00 BSC | | |
| D1 | 0.50 | 0.65 | 0.75 |
| D2 | 1.24 | 1.39 | 1.49 |
| E | 3.00 BSC | | |
| E1 | 1.55 | 1.70 | 1.80 |
| ⓐ | 0.50 BSC | | |
| L | 0.28 | 0.38 | 0.48 |
| L1 | 0.47 | 0.57 | 0.67 |
| L2 | 0.07 | 0.17 | 0.27 |
| L3 | 0.27 REF. | | |
| R | 0.15 REF | | |
| aaa | 0.15 | | |
| bbb | 0.10 | | |
| ccc | 0.10 | | |
| ddd | 0.08 | | |

Dimensions in inches

| Symbols | Min. | Nom. | Max. |
|---------|------------|-------|-------|
| A | 0.031 | 0.035 | 0.039 |
| A1 | 0.000 | 0.001 | 0.002 |
| A3 | 0.008 REF | | |
| b | 0.008 | 0.009 | 0.013 |
| D | 0.118 BSC | | |
| D1 | 0.020 | 0.026 | 0.030 |
| D2 | 0.049 | 0.055 | 0.059 |
| E | 0.118 BSC | | |
| E1 | 0.061 | 0.067 | 0.071 |
| ⓐ | 0.020 BSC | | |
| L | 0.011 | 0.015 | 0.019 |
| L1 | 0.019 | 0.022 | 0.026 |
| L2 | 0.003 | 0.007 | 0.011 |
| L3 | 0.011 REF. | | |
| R | 0.006 REF | | |
| aaa | 0.006 | | |
| bbb | 0.004 | | |
| ccc | 0.004 | | |
| ddd | 0.003 | | |

Notes:

1. All dimensions are in millimeters.

2. The location of the terminal #1 identifier and terminal numbering convention conforms to JEDEC publication 95 SPP-002.

3. Dimension b applies to metallized terminal and is measured between 0.20mm and 0.35mm from the terminal tip. If the terminal has the optional radius on the other end of the terminal, the dimension b should not be measured in that radius area.

4. Coplanarity applies to the terminals and all other bottom surface metallization.

Tape and Reel Dimensions, DFN3X3 10L EP2

Tape

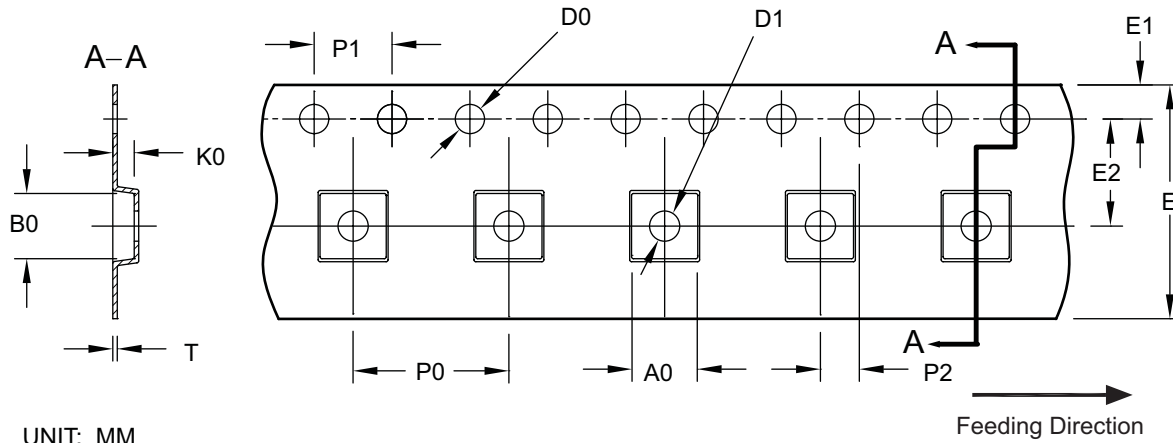

UNIT: MM

| Package | A0 | B0 | K0 | D0 | D1 | E | E1 | E2 | P0 | P1 | P2 | T |
|------------|---------------|---------------|---------------|---------------------|---------------------|----------------|---------------|---------------|---------------|---------------|---------------|---------------|
| DFN 3x3 EP | 3.40 ±0.10 | 3.35 ±0.10 | 1.10 ±0.10 | 1.50 +0.10 -0 | 1.50 +0.10 -0 | 12.00 ±0.30 | 1.75 ±0.10 | 5.50 ±0.05 | 8.00 ±0.10 | 4.00 ±0.10 | 2.00 ±0.05 | 0.30 ±0.05 |

Reel

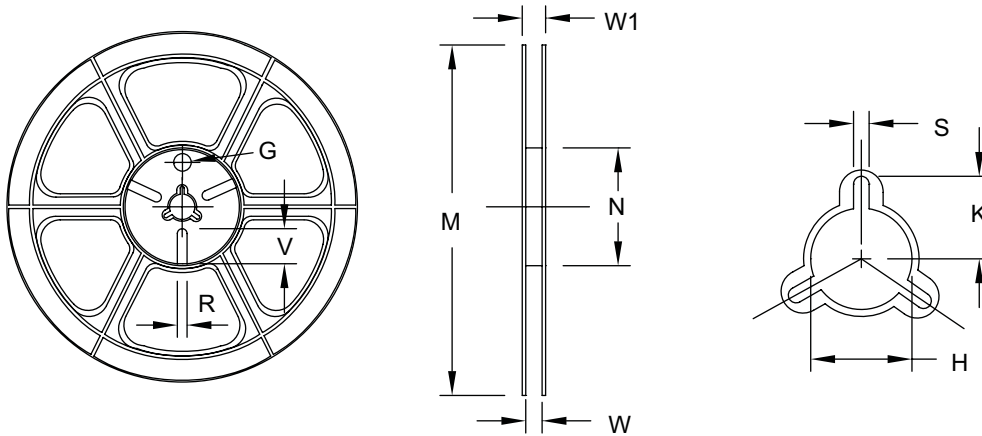

UNIT: mm

| Tape Size | Reel Size | M | N | W | W1 | H | K | S | G | R | V |
|-----------|-----------|------------------|-----------------|----------------|----------------|-------------------------|-------|---------------|---|---|---|
| 12mm | ø330 | ø330.00 ±0.50 | ø97.00 ±0.10 | 13.00 ±0.30 | 17.40 ±1.00 | ø13.00 +0.50 / -0.20 | 10.60 | 2.00 ±0.50 | - | - | - |

Leader/Trailer and Orientation

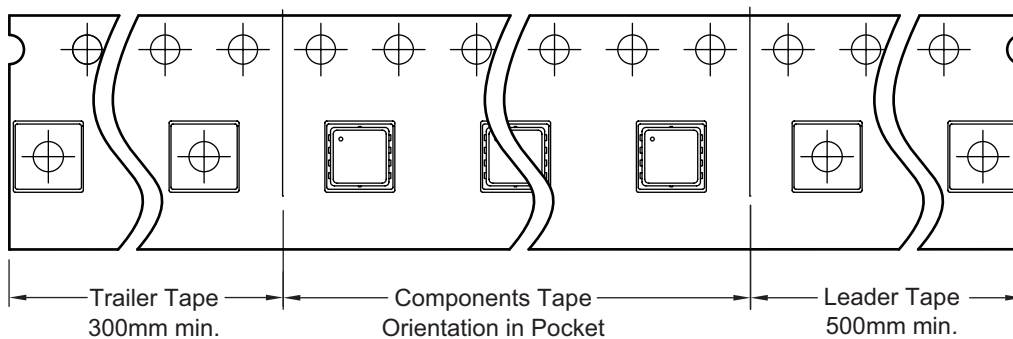

Package Marking

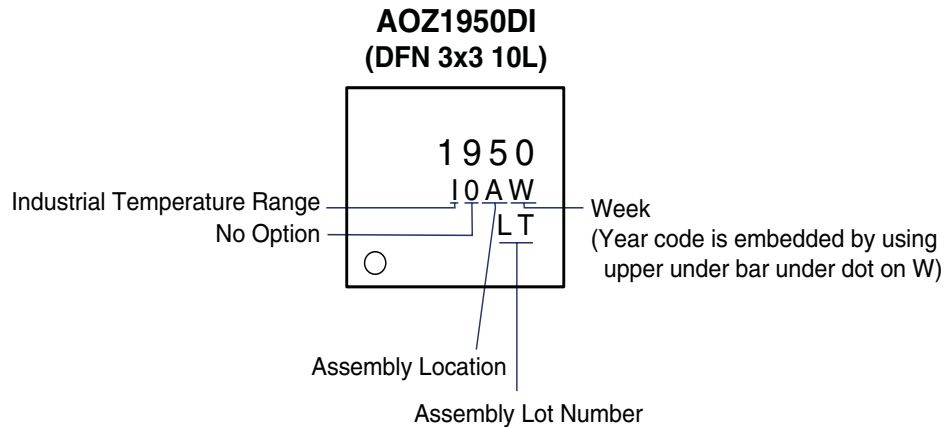

This data sheet contains preliminary data; supplementary data may be published at a later date. Alpha & Omega Semiconductor reserves the right to make changes at any time without notice.

LIFE SUPPORT POLICY

ALPHA & OMEGA SEMICONDUCTOR PRODUCTS ARE NOT AUTHORIZED FOR USE AS CRITICAL COMPONENTS IN LIFE SUPPORT DEVICES OR SYSTEMS.

As used herein:

1. Life support devices or systems are devices or systems which, (a) are intended for surgical implant into the body or (b) support or sustain life, and (c) whose failure to perform when properly used in accordance with instructions for use provided in the labeling, can be reasonably expected to result in a significant injury of the user.
2. A critical component in any component of a life support, device, or system whose failure to perform can be reasonably expected to cause the failure of the life support device or system, or to affect its safety or effectiveness.