

## General Description

The AOZ2264VQI is a high-efficiency, easy-to-use DC/DC synchronous buck regulators capable of operation from a 4V to 28V input bus. The device is capable of supplying 16A of continuous output current with an output voltage adjustment from 0V to 1.8V by controlling VID0 and VID1 signals.

A proprietary constant on-time PWM control with input feed-forward results in ultra-fast transient response while maintaining relatively constant switching frequency over the entire input voltage range.

The devices feature multiple protection functions such as  $V_{CC}$  under-voltage lockout, cycle-by-cycle current limit, output over-voltage protection, short-circuit protection, and thermal shutdown.

The AOZ2264VQI is available in a 4mm×4mm QFN-23L package and is rated over a -40°C to +85°C ambient temperature range.

## Features

- Wide input voltage range:
  - 4V to 28V
- Support Intel  $I_{TDC}$  up to 16A
- Support Intel  $ICC_{MAX}$  up to 32A
- 2 bits programmable output voltage adjustable from 0V to 1.8V
- Integrated high performance trench MOSFETs capable of:
  - High peak current
    - Up to 47A with 10ms on pulse
    - Up to 70A with 10μs on pulse
  - High efficiency
    - 11 mΩ high-side
    - 4 mΩ low-side
- Constant On-Time with input feed-forward
- Ripple Reduction at light load
- Remote sense
- Ceramic capacitor stable
- Fixed soft start
- Power Good output
- Integrated bootstrap diode
- Cycle-by-cycle current limit
- Short-circuit protection
- Over-voltage protection
- Thermal shutdown
- Thermally enhanced 23-pin 4m×4m QFN

## Applications

- Portable computers
- Compact desktop PCs
- Servers
- Networking equipment



## Typical Application

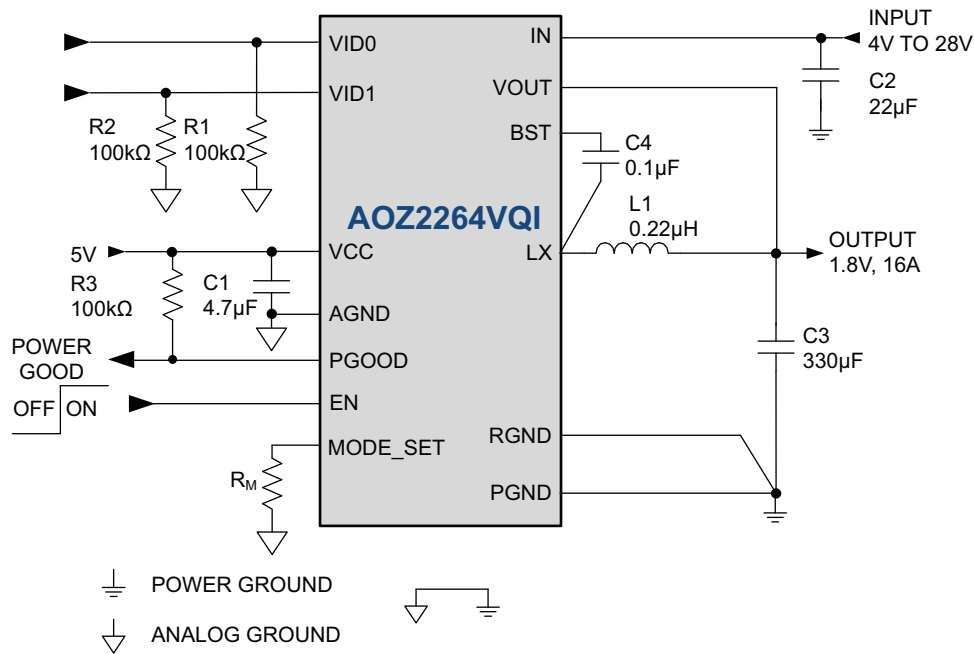

## Ordering Information

Part Number	Ambient Temperature Range	Package	Environmental
AOZ2264VQI	-40°C to +85°C	23-Pin 4m×4m QFN	Green Product



AOS Green Products use reduced levels of Halogens, and are also RoHS compliant.  
[www.aosmd.com/media/AOSGreenPolicy.pdf](http://www.aosmd.com/media/AOSGreenPolicy.pdf) for additional information.

## Pin Configuration

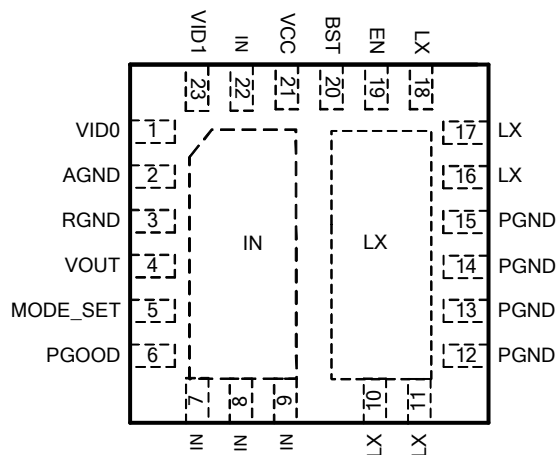

**23-Pin 4mm x 4mm QFN**  
(Top Transparent View)

## Pin Description

Pin Number	Pin Name	Pin Function
1	VID 0	VID Interface.
2	AGND	Analog Ground.
3	RGND	Remote Sensing GND. Connection to GND of the load.
4	VOUT	Output Voltage Feedback Input. Connection to the output voltage.
5	MODE_SET	Auto-skip and Decay Mode Setting Input. Connect a resistor between MODS_SET and GND to set the operating mode.
6	PGOOD	Power Good Signal Output. PGOOD is an open-drain output used to indicate the status of the output voltage. It is internally pulled low when the output voltage is 15% lower than the nominal regulation voltage for or higher than 2.2V. PGOOD is pulled low during soft-start and shut down.
7, 8, 9, 22	IN	Supply Input. IN is the regulator input. All IN pins must be connected together.
10, 11, 16, 17, 18	LX	Switching Node.
12, 13, 14, 15	PGND	Power Ground.
19	EN	Enable Input. The AOZ2264VQI is enabled when EN is pulled high. The device shuts down when EN is pulled low. Assert EN to high for power-up after IN and VCC are well supplied
20	BST	Bootstrap Capacitor Connection. The AOZ2264VQI includes an internal bootstrap diode. Connect an external capacitor between BST and LX as shown in Typical Application diagram.
21	VCC	Supply Input for analog functions. Bypass VCC to AGND with a 4.7 $\mu$ F~10 $\mu$ F ceramic capacitor. Place the capacitor close to VCC pin.
23	VID 1	VID Interface.

## Absolute Maximum Ratings

Exceeding the Absolute Maximum Ratings may damage the device.

Parameter	Rating
IN to AGND	-0.3V to 30V
LX to AGND <sup>(1)</sup>	-0.7V to 30V
BST to AGND	-0.3V to 36V
PGND to AGND	-0.3V to +0.3V
Other Pins to AGND	-0.3V to 6V
Junction Temperature (T <sub>J</sub> )	+150°C
Storage Temperature (T <sub>S</sub> )	-65°C to +150°C
ESD Rating-HBM <sup>(2)</sup>	2kV
ESD Rating-CDM	1kV

### Notes:

- LX to PGND Transient (t<20ns) ----- -7V to V<sub>IN</sub>+7V.
- Devices are inherently ESD sensitive, handling precautions are required. Human body model rating: 1.5kΩ in series with 100pF.

## Maximum Operating Ratings

The device is not guaranteed to operate beyond the Maximum Operating ratings.

Parameter	Rating
Supply Voltage (V <sub>IN</sub> )	4V to 28V
Output Voltage Range	0V to 1.8V
Ambient Temperature (T <sub>A</sub> )	-40°C to +85°C
Operating Junction Temperature (T <sub>J</sub> )	-40°C to +145°C
Package Thermal Resistance (θ <sub>JA</sub> ) (θ <sub>JC</sub> )	32°C/W 4°C/W

## Electrical Characteristics

T<sub>A</sub> = 25°C, V<sub>IN</sub> = 12V, V<sub>CC</sub> = 5V, EN = 5V, unless otherwise specified. Specifications in **BOLD** indicate a temperature range of -40°C to +85°C.

Symbol	Parameter	Conditions	Min	Typ	Max	Units
V <sub>IN</sub>	IN Supply Voltage		<b>4</b>		<b>28</b>	V
V <sub>UVLO</sub>	Under-Voltage Lockout Threshold of V <sub>CC</sub>	V <sub>CC</sub> rising V <sub>CC</sub> falling		<b>4.5</b> <b>4.1</b>		V
I <sub>SLEEP</sub>	Sleep Mode Supply Current of V <sub>CC</sub>	I <sub>OUT</sub> = 0A, V <sub>EN</sub> ≥ 2V, VID[1,0]=00		<b>70</b>	<b>100</b>	μA
I <sub>OFF</sub>	Shutdown Supply Current	V <sub>EN</sub> = 0V		1	2	μA
V <sub>OUT</sub>	Output Voltage	VID[1,0]=00		0		V
		VID[1,0]=01		1.1		
		VID[1,0]=10		1.65		
		VID[1,0]=11		1.8		
T <sub>RAMP_UP</sub>	Ramp Up Time				149	μs
T <sub>RAMP_DO WN</sub>	Ramp Down Time	Does not apply for Decay mode			149	μs
<b>VID 0 and VID 1</b>						
V <sub>ID</sub>	VID 0&VID1 Input Threshold	Low threshold High threshold	2.6		0.3	V V
V <sub>ID_HYS</sub>	VID 0&VID1 Input Hysteresis			2		V
<b>Modulator</b>						
f <sub>SW</sub>	Operating Frequency			450		kHz
T <sub>ON</sub>	Normal On Time	V <sub>IN</sub> =12V, VID[1,0]=01		200		ns
		V <sub>IN</sub> =12V, VID[1,0]=10		300		ns
		V <sub>IN</sub> =12V, VID[1,0]=11		330		ns
T <sub>OFF_MIN</sub>	Minimum Off Time			300		ns

## Electrical Characteristics

$T_A = 25^\circ\text{C}$ ,  $V_{IN} = 12\text{V}$ ,  $V_{CC} = 5\text{V}$ ,  $EN = 5\text{V}$ , unless otherwise specified. Specifications in **BOLD** indicate a temperature range of  $-40^\circ\text{C}$  to  $+85^\circ\text{C}$ .

Symbol	Parameter	Conditions	Min	Typ	Max	Units
<b>MODE_SET</b>						
$I_{MS}$	MODE_SET Current Source			5		$\mu\text{A}$
<b>Soft-Start</b>						
$T_{SS\_OUT}$	SS Time	For PGOOD signal is pulled high		1.5		ms
<b>Power Good Signal</b>						
$V_{PG\_LOW}$	PGOOD Low Voltage	$I_{OL} = 1\text{mA}$			0.5	V
	PGOOD Leakage Current				$\pm 1$	$\mu\text{A}$
$V_{PGH}$	PGOOD Threshold (Low level to High level)	VOUT rising		90		%
$V_{PGL}$	PGOOD Threshold (High level to Low level)	VOUT rising (over $5\mu\text{s}$ ) VOUT falling		2.2 85		V %
	PGOOD Threshold Hysteresis			5		%
$T_{PG\_DB}$	De-bounce Time for PGOOD	PGOOD signal from low to high		20	30	$\mu\text{s}$
<b>Under-Voltage and Over-Voltage Protection</b>						
$V_{PL}$	Under-Voltage Threshold	VOUT falling		50		%
$V_{PH}$	Over-Voltage Threshold	VOUT rising		2.2		V
<b>Power Stage Output</b>						
$R_{DS(ON)}$	High-Side NFET On-Resistance	$V_{IN} = 12\text{V}$ , $V_{CC} = 5\text{V}$		11		$\text{m}\Omega$
	High-Side NFET Leakage	$V_{EN} = 0\text{V}$ , $V_{LX} = 0\text{V}$			10	$\mu\text{A}$
$R_{DS(ON)}$	Low-Side NFET On-Resistance	$V_{LX} = 12\text{V}$ , $V_{CC} = 5\text{V}$		4		$\text{m}\Omega$
	Low-Side NFET Leakage	$V_{EN} = 0\text{V}$			10	$\mu\text{A}$
<b>Enable</b>						
$V_{EN}$	EN Input Threshold	Off threshold On threshold	1.3		0.6	V
$V_{EN\_HYS}$	EN Input Hysteresis			300		mV
<b>Over-current and Thermal Protection</b>						
$I_{LIM\_SC}$	Source Current Limit	$V_{CC} = 5\text{V}$	42			A
$I_{LIM\_SK}$	Sink Current Limit	$V_{CC} = 5\text{V}$	24			A
	Thermal Shutdown Threshold	$T_J$ rising		150		$^\circ\text{C}$

### Functional Block Diagram

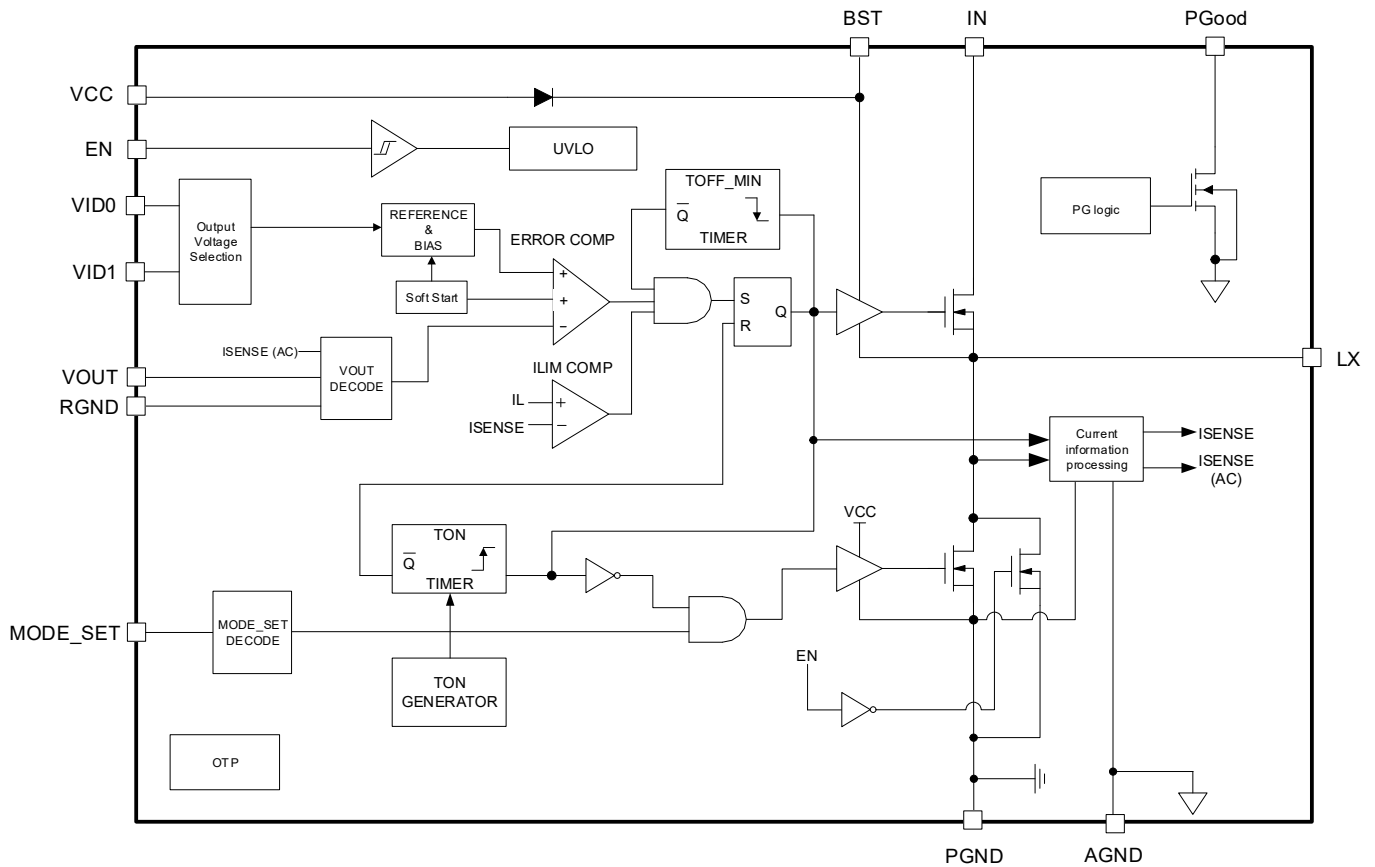

## Typical Performance Characteristics

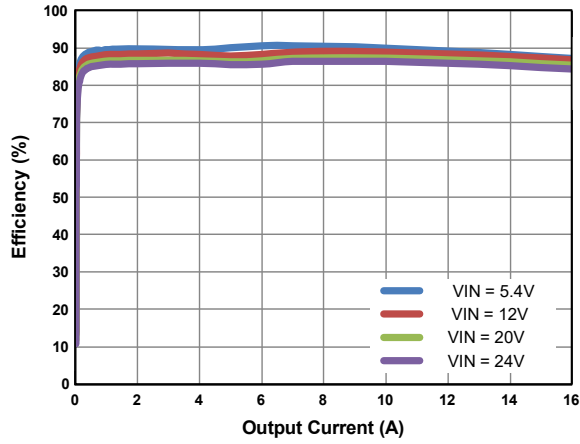

Figure 1. Efficiency vs. Load Current  
(V<sub>OUT</sub>=1.8V)

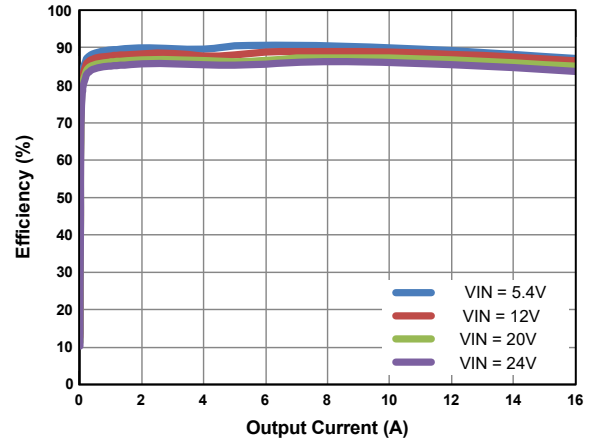
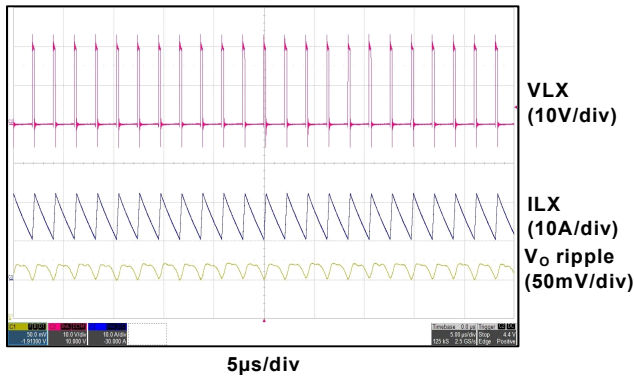

Figure 2. Efficiency vs. Load Current  
(V<sub>OUT</sub>=1.65V)

## Typical Performance Characteristics

$T_A = 25^\circ\text{C}$ ,  $V_{IN} = 20\text{V}$ ,  $V_{OUT} = 1.8\text{V}$ , (VID[1:0]=11),  $L = 0.22\mu\text{H}$  unless otherwise specified.

Normal Operation



Load Transient 0A to 16A

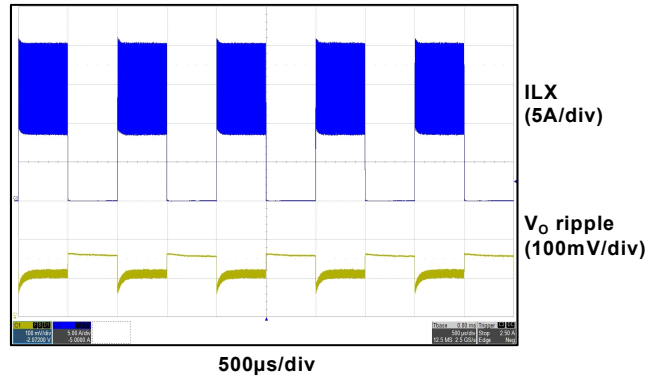

Full Load Start-up

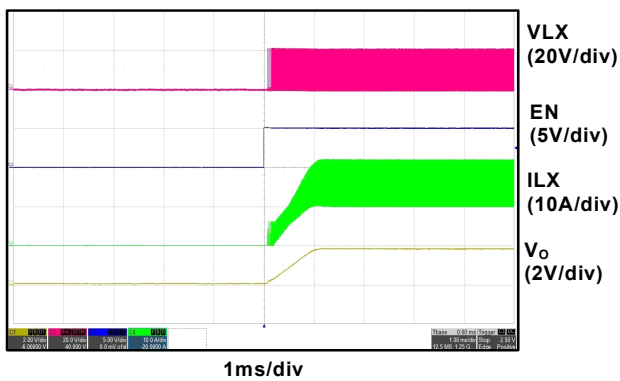

Short Circuit Protection

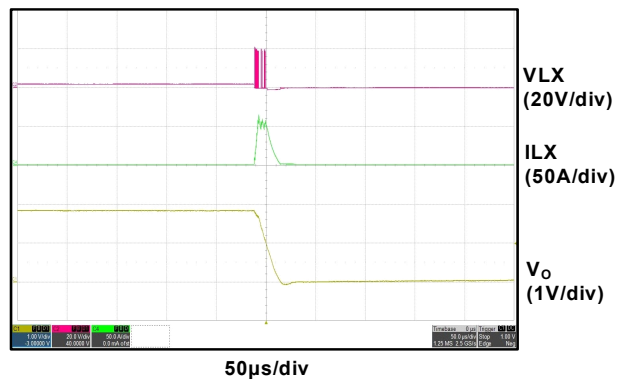

VID Change 1.8V to 0V

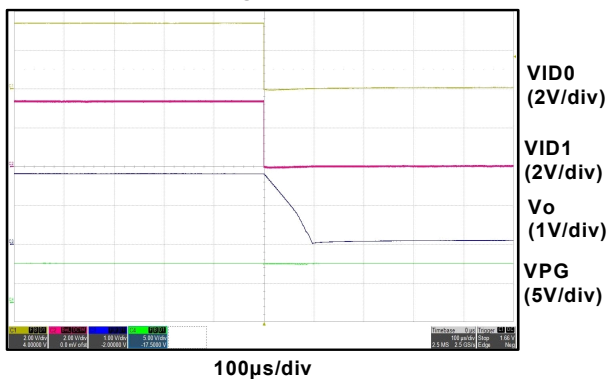

VID Change 0V to 1.8V

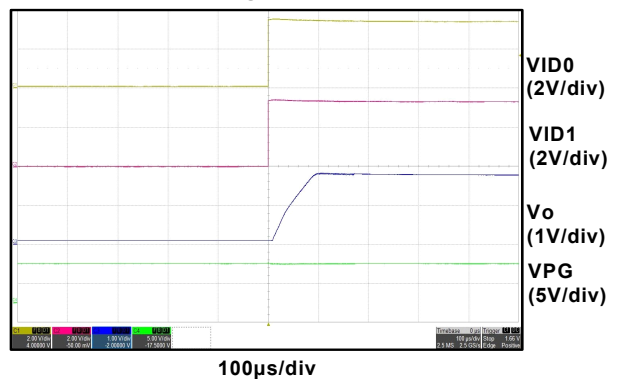



## Typical Performance Characteristics

$T_A = 25^\circ\text{C}$ ,  $V_{IN} = 20\text{V}$ ,  $V_{OUT} = 1.65\text{V}$ , (VID[1:0]=10),  $L = 0.22\mu\text{H}$  unless otherwise specified.

Normal Operation

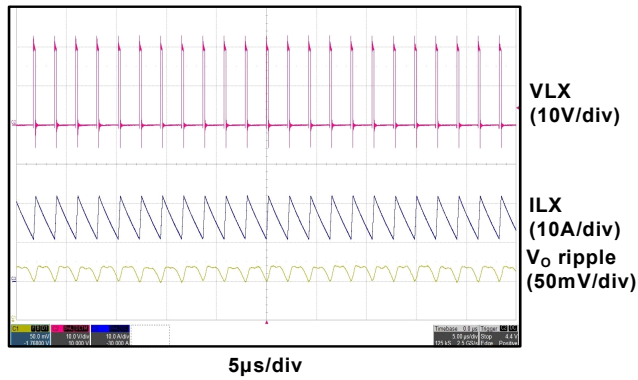

Load Transient 0A to 16A

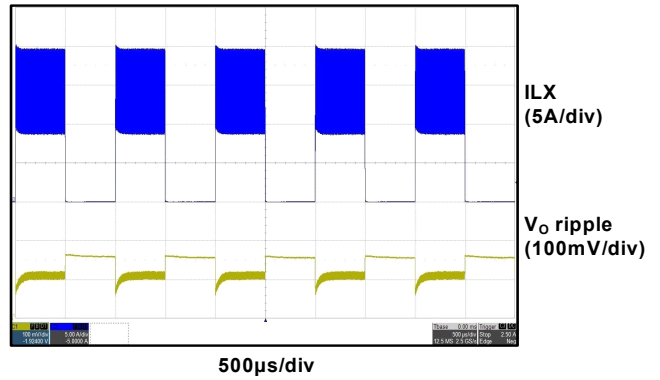

Full Load Start-up

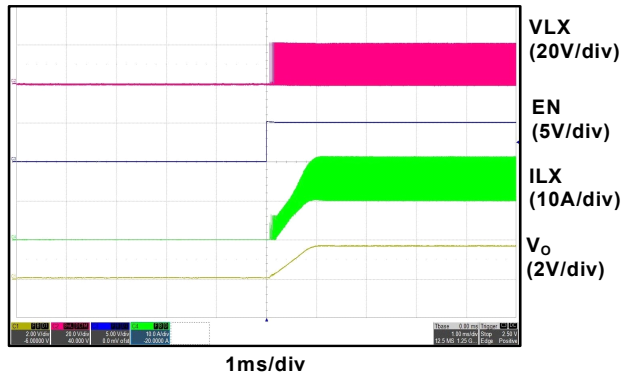

Short Circuit Protection

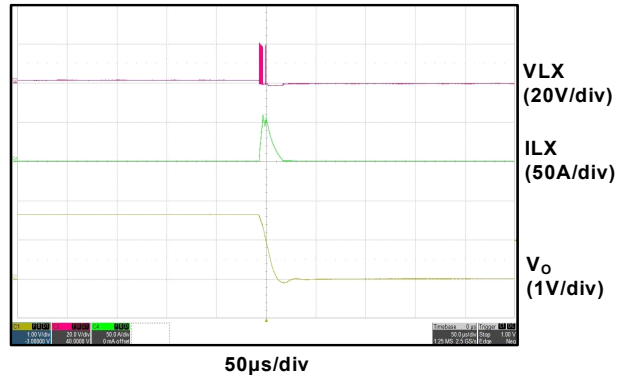

VID Change 1.65V to 0V

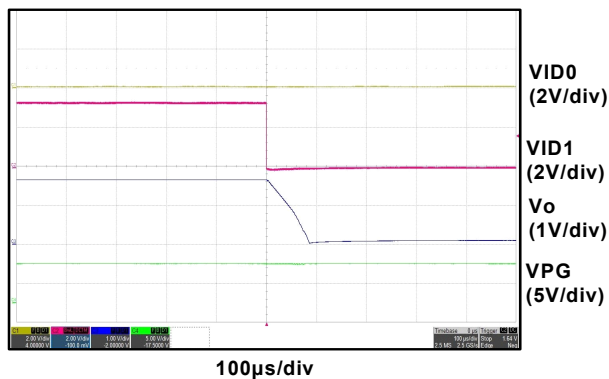

VID Change 0V to 1.65V

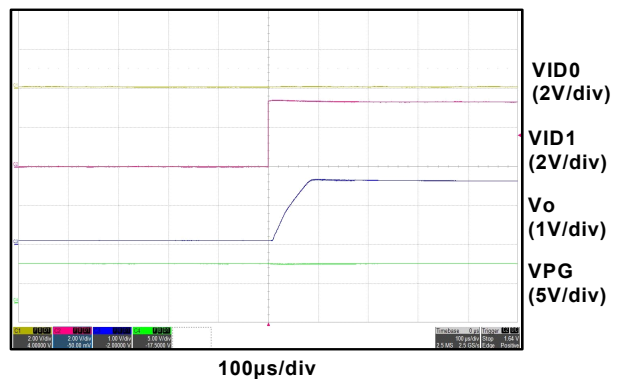

## Detailed Description

The AOZ2264VQI is a high-efficiency, easy-to-use DC/DC synchronous buck regulators capable of operation from a 4V to 28V input bus. The device is capable of supplying 16A of continuous output current with an output voltage adjustment from 0V to 1.8V by controlling VID0 and VID1 signals.

Constant on-time PWM with input feed-forward control scheme results in ultra-fast transient response while maintaining relatively constant switching frequency over the entire input range. True AC current mode control scheme guarantees the regulators can be stable with ceramics output capacitor. Protection features include  $V_{CC}$  under-voltage lockout, cycle-by-cycle current limit, output over voltage and under voltage protection, short-circuit protection, and thermal shutdown.

The AOZ2264VQI is available in 23-pin 4mm×4mm QFN package.

### Enable and Soft Start

The AOZ2264VQI has internal soft start feature to limit in-rush current and ensure the output voltage ramps up smoothly to regulation voltage. A soft start process begins when  $V_{CC}$  rises to 4.5V and voltage on EN pin is HIGH. The output voltage follows the internal voltage of soft-start ( $V_{SS}$ ) when it is lower than initial output voltage. When  $V_{SS}$  is higher than initial output voltage, the voltage of VOUT pin is regulated by internal precise band-gap voltage. Moreover, the soft start period between EN and PGOOD is 1.5ms. The soft start sequence of AOZ2264VQI is shown in Figure 3.

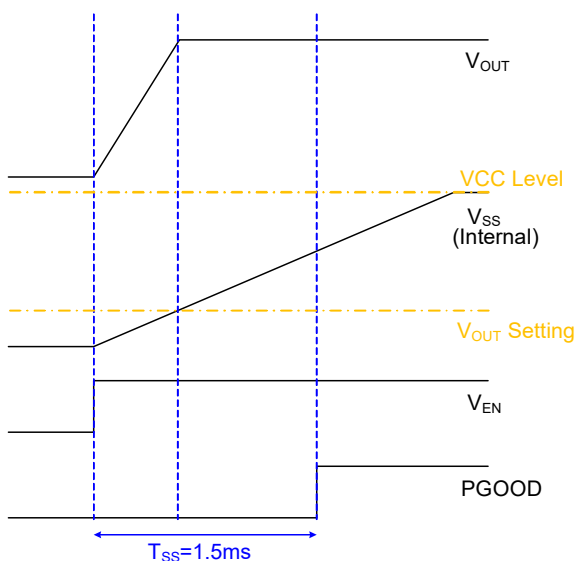

Figure 3. Soft Start Sequence

### Constant-On-Time PWM Control with Input Feed-Forward

The control algorithm of AOZ2264VQI is constant-on-time PWM Control with input feed-forward.

The simplified control schematic is shown in Figure 4. The high-side switch on-time is determined solely by a one-shot whose pulse width is inversely proportional to input voltage (IN). The one-shot is triggered when the internal setting output voltage is higher than the combined information of output voltage and the AC current information of inductor and load line signal, which is processed and obtained through the sensed low-side MOSFET current once it turns-on. The added AC current information can help the stability of constant-on time control even with pure ceramic output capacitors, which have very low ESR. The AC current information has no DC offset, which does not cause offset with output load change, which is fundamentally different from other  $V^2$  constant-on time control schemes.

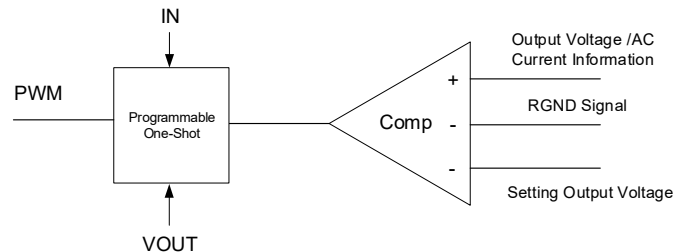

Figure 4. Simplified Control Schematic

### True Current Mode Control

The constant-on-time control scheme is intrinsically unstable if output capacitor's ESR is not large enough as an effective current-sense resistor. Ceramic capacitors usually cannot be used as output capacitor.

The AOZ2264VQI senses the low-side MOSFET current and processes it into DC current and AC current information using AOS proprietary technique. The AC current information is decoded and added on the VOUT pin on phase. With AC current information, the stability of constant-on-time control is significantly improved even without the help of output capacitor's ESR; and thus the pure ceramic capacitor solution can be applicable. The pure ceramic capacitor solution can significantly reduce the output ripple (no ESR caused overshoot and undershoot) and less board area design.

### Auto-Skip and Decay Mode

The AOZ2264VQI has the auto-skip mode control function to achieve higher efficiency at light load condition. When the output current decreases, the inductor current also reduces. If the inductor current valley point reaches to zero current, the AOZ2264VQI operates at auto-skip mode. It means the zero current is the boundary between pulse-width mode and auto-skip mode. As the inductor current reaches to zero current, the low-side MOSFET is turned off, and then the AOZ2264VQI operates at tri-state for auto-skip mode. Until output voltage is less than reference voltage, the on time signal is triggered to turn on high-side MOSFET.

The AOZ2264VQI also has the decay mode function to implement power saving when there are frequent transitions from higher output voltage to lower one, the regulator output stops switching and goes high impedance. The output naturally decays into the load. The decay mode illustration is shown in Figure 5.

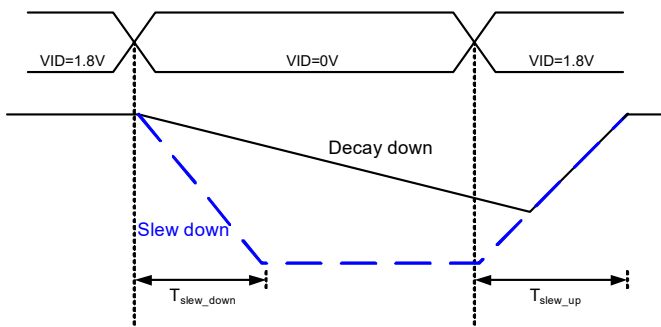

Figure 5. Decay Mode Illustration

Moreover, When the VID changes to a lower set point at slew mode (non-decay mode), the regulator output still switches to discharge by 64 cycles on time. The slew mode illustration is shown in Figure 6.

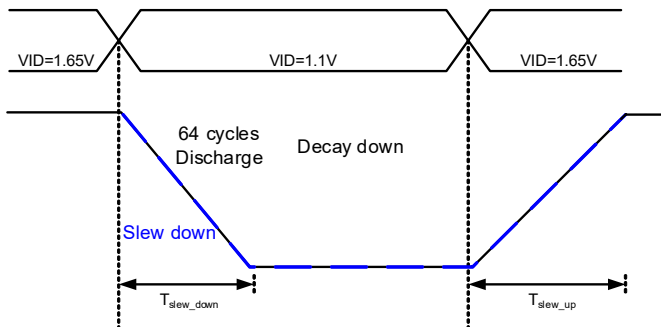

Figure 6. Slew Mode Illustration

### 2 Bits Programmable VID

The AOZ2264VQI implements an output voltage adjustment by controlling VID0 and VID1 signals. Table 1 shows the output voltage for corresponding VID setting.

Table 1. Output Voltage for Corresponding VID Setting

VOUT Setting	VID 0	VID 1
1.8V	1	1
1.65V	0	1
1.1V	1	0
0V	0	0

### Mode Selection

The AOZ2264VQI can select operating modes for auto-skip mode or decay mode by MODE\_SET pin. The internal circuit has a current source  $I_{MS}$  which flows out the MODE\_SET pin. When MODE\_SET connect to a resistor, the  $I_{MS}$  flows through a resistor, a voltage  $V_{MODE}$  is produced, and then the  $V_{MODE}$  is compared by MODE threshold to determine AOZ2264VQI operating mode. The MODE\_SET Internal Circuit illustration is shown in Figure 7.

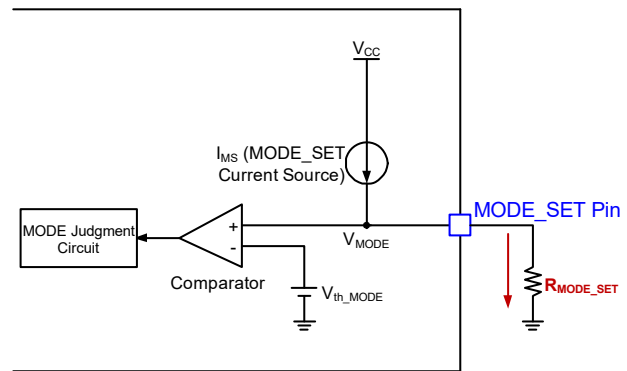

Figure 7. MODE\_SET Internal Circuit Illustration

Table 2 shows the MODE\_SET setting for corresponding modes.

Table 2. MODE\_SET Setting for Corresponding Modes

MODE_SET	Auto-skip Mode	Decay down Mode	Recommended Resistor
5.0V	Off	On	Connect to VCC or 1M $\Omega$
2.0V	Off	Off	400k $\Omega$
1.0V	On	Off	200k $\Omega$
0V	On	On	Connect to GND or 0 $\Omega$

### Remote Sensing Function

The AOZ2264VQI provides the remote sensing function to implement better load regulation in high current application. The VOUT and RGND pins need to connect to the load terminal by kelvin-sensing method. It can compensate the voltage drop from PCB ESR to the setting output voltage that we want. The remote sensing traces (VOUT and RGND return trace) should be far away against from switching signals and high current paths on PCB application. Figure 8 shows the remote sensing connection.

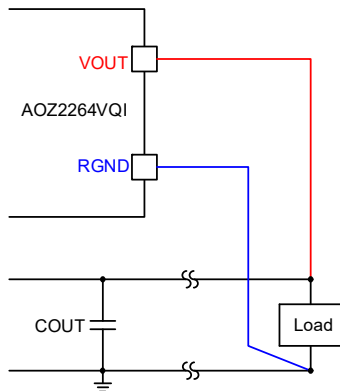

Figure 8. Decay Mode Illustration for Sleep Mode

### Current-Limit Protection

The AOZ2264VQI has the current-limit protection by using  $R_{dson}$  of the low-side MOSFET to be as current sensing. To detect real current information, a minimum constant off time (300nS typical) is implemented after a constant-on time. If the current exceeds the current-limit threshold, the PWM controller is not allowed to initiate a new cycle. The actual peak current is greater than the current-limit threshold by an amount equal to the inductor ripple current. Therefore, exact current-limit characteristic and maximum load capability are a function of the inductor value and input and output voltages. The current limit will keep the low-side MOSFET on and will not allow another high-side on-time, until the current in the low-side MOSFET reduces below the current limit.

After 16 switching cycles, the AOZ2264VQI considers this is a true failed condition and thus turns-off both high-side and low-side MOSFET and latches off. Only trigger the enable again can restart the AOZ2264VQI.

### Output Voltage Under-voltage Protection

If the output voltage is lower than 50% by over-current or short circuit, AOZ2264VQI turns-off both high-side and low-side MOSFET and latches off. Only trigger the enable again can restart the AOZ2264VQI.

### Output Voltage Over-voltage Protection

The threshold of OVP is set on 2.2V. When the output voltage exceeds the OVP threshold, high-side and low-side MOSFET are turned-off. If the time is over 5 $\mu$ s for the output voltage is higher than the OVP threshold, AOZ2264VQI is latched-off. Only trigger the enable again can restart the AOZ2264VQI.

### Power Good Output

The power good (PGOOD) output, which is an open drain output, requires the pull-up resistor. When the output voltage is 15% below the nominal regulation voltage for, the PGOOD is pulled low. When the output voltage is higher than 2.2V, the PGOOD is also pull low.

When combined with the under-voltage-protection circuit, this current-limit method is effective in almost every circumstance.

### Ripple Reduction

When switching frequency is down to half of setting during PFM, AOZ2264VQI actively reduces on-time pulse width to reduce inductor current ripple and output voltage ripple. Ripple reduction not only reduces half of voltage ripple but also decreased the chance of acoustic noise under light load.

### Application Information

The basic AOZ2264VQI application circuit is shown in Typical Application diagram. Component selection is explained below.

### Input Capacitor

The input capacitor must be connected to the IN pins and PGND pin of the AOZ2264VQI to maintain steady input voltage and filter out the pulsing input current. A small decoupling capacitor, usually 4.7 $\mu$ F, should be connected to the V<sub>CC</sub> pin and AGND pin for stable operation of the AOZ2264VQI. The voltage rating of input capacitor must be greater than maximum input voltage plus ripple voltage.

The input ripple voltage can be approximated by equation below:

$$\Delta V_{IN} = \frac{I_O}{f \times C_{IN}} \times \left(1 - \frac{V_O}{V_{IN}}\right) \times \frac{V_O}{V_{IN}}$$

Since the input current is discontinuous in a buck converter, the current stress on the input capacitor is another concern when selecting the capacitor.

For a buck circuit, the RMS value of input capacitor current can be calculated by:

$$I_{CIN\_RMS} = I_O \times \sqrt{\frac{V_O}{V_{IN}} \left(1 - \frac{V_O}{V_{IN}}\right)}$$

if let  $m$  equal the conversion ratio:

$$\frac{V_O}{V_{IN}} = m$$

The relation between the input capacitor RMS current and voltage conversion ratio is calculated and shown in Figure 9. It can be seen that when  $V_O$  is half of  $V_{IN}$ ,  $C_{IN}$  is under the worst current stress. The worst current stress on  $C_{IN}$  is  $0.5 \cdot I_O$ .

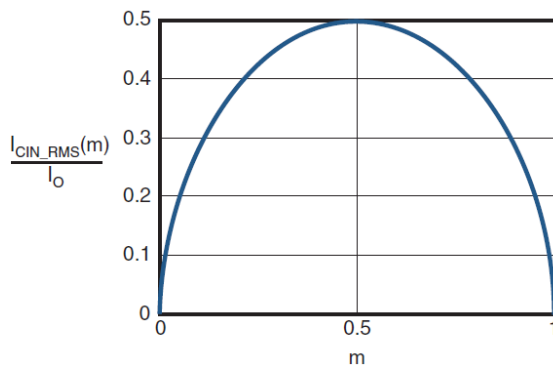

Figure 9.  $I_{CIN}$  vs. Voltage Conversion Ratio

For reliable operation and best performance, the input capacitors must have current rating higher than  $I_{CIN-RMS}$  at worst operating conditions. Ceramic capacitors are preferred for input capacitors because of their low ESR and high ripple current rating. Depending on the application circuits, other low ESR tantalum capacitor or aluminum electrolytic capacitor may also be used. When selecting ceramic capacitors, X5R or X7R type dielectric ceramic capacitors are preferred for their better temperature and voltage characteristics. Note that the ripple current rating from capacitor manufactures is based on certain amount of life time. Further de-rating may be necessary for practical design requirement.

### Inductor

The inductor is used to supply constant current to output when it is driven by a switching voltage. For given input and output voltage, inductance and switching frequency together decide the inductor ripple current, which is:

$$\Delta I_L = \frac{V_O}{f \times L} \times \left(1 - \frac{V_O}{V_{IN}}\right)$$

The peak inductor current is:

$$I_{Lpeak} = I_O + \frac{\Delta I_L}{2}$$

High inductance gives low inductor ripple current but requires larger size inductor to avoid saturation. Low ripple current reduces inductor core losses. It also reduces RMS current through inductor and switches, which results in less conduction loss. Usually, peak to peak ripple current on inductor is designed to be 30% to 50% of output current.

When selecting the inductor, make sure it is able to handle the peak current without saturation even at the highest operating temperature.

The inductor takes the highest current in a buck circuit. The conduction loss on inductor needs to be checked for thermal and efficiency requirements.

Surface mount inductors in different shape and styles are available from Coilcraft, Elytone and Murata. Shielded inductors are small and radiate less EMI noise. But they cost more than unshielded inductors. The choice depends on EMI requirement, price and size.

### Output Capacitor

The output capacitor is selected based on the DC output voltage rating, output ripple voltage specification and ripple current rating.

The selected output capacitor must have a higher rated voltage specification than the maximum desired output voltage including ripple. De-rating needs to be considered for long term reliability.

Output ripple voltage specification is another important factor for selecting the output capacitor. In a buck converter circuit, output ripple voltage is determined by inductor value, switching frequency, output capacitor value and ESR. It can be calculated by the equation below:

$$\Delta V_O = \Delta I_L \times \left(ESR_{CO} + \frac{1}{8 \times f \times C_O}\right)$$

where  $C_O$  is output capacitor value and  $ESR_{CO}$  is the Equivalent Series Resistor of output capacitor.

When low ESR ceramic capacitor is used as output capacitor, the impedance of the capacitor at the switching frequency dominates. Output ripple is mainly caused by

capacitor value and inductor ripple current. The output ripple voltage calculation can be simplified to:

$$\Delta V_O = \Delta I_L \times \frac{1}{8 \times f \times C_O}$$

If the impedance of ESR at switching frequency dominates, the output ripple voltage is mainly decided by capacitor ESR and inductor ripple current. The output ripple voltage calculation can be further simplified to:

$$\Delta V_O = \Delta I_L \times ESR_{CO}$$

For lower output ripple voltage across the entire operating temperature range, X5R or X7R dielectric type of ceramic, or other low ESR tantalum are recommended to be used as output capacitors.

In a buck converter, output capacitor current is continuous. The RMS current of output capacitor is decided by the peak to peak inductor ripple current. It can be calculated by:

$$I_{CO\_RMS} = \frac{\Delta I_L}{\sqrt{12}}$$

Usually, the ripple current rating of the output capacitor is a smaller issue because of the low current stress. When the buck inductor is selected to be very small and inductor ripple current is high, output capacitor could be overstressed.

### Power MOSFET SOA Curve

AOZ2264VQI integrates AOS' state of the art Trench MOSFETs. Robust SOA ensures reliable operation in high performance buck regulator applications.

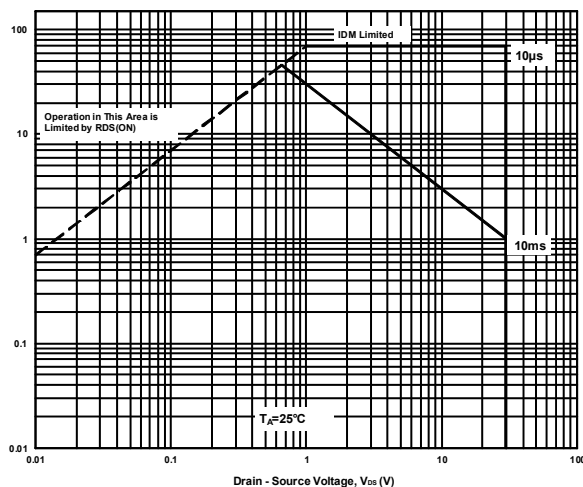

Figure 10. High-Side MOSFET SOA Curve

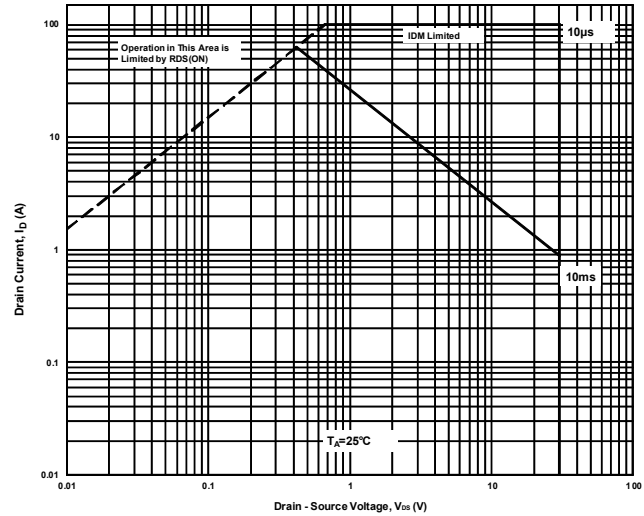

Figure 11. Low-Side MOSFET SOA Curve

### Thermal Management and Layout Consideration

In the AOZ2264VQI buck regulator circuit, high pulsing current flows through two circuit loops. The first loop starts from the input capacitors, to the IN pin, to the LX pins, to the filter inductor, to the output capacitor and load, and then return to the input capacitor through ground. Current flows in the first loop when the high side switch is on. The second loop starts from inductor, to the output capacitors and load, to the low side switch. Current flows in the second loop when the low side low side switch is on.

In PCB layout, minimizing the two loops area reduces the noise of this circuit and improves efficiency. A ground plane is strongly recommended to connect input capacitor, output capacitor, and PGND pin of the AOZ2264VQI.

In the AOZ2264VQI buck regulator circuit, the major power dissipating components are the AOZ2264VQI and the output inductor. The total power dissipation of converter circuit can be measured by input power minus output power.

$$P_{total\_loss} = V_{IN} \cdot I_{IN} - V_O \cdot I_O$$

The power dissipation of inductor can be approximately calculated by DCR of inductor and output current.

$$P_{inductor\_loss} = I_O^2 \cdot R_{inductor} \cdot 1.1$$



The actual junction temperature can be calculated with power dissipation in the AOZ2264VQI and thermal impedance from junction to ambient.

$$T_{junction} = (P_{total\_loss} - P_{inductor\_loss}) \cdot \Theta_{JA} + T_A$$

The maximum junction temperature of AOZ2264VQI is 150°C, which limits the maximum load current capability.

The thermal performance of the AOZ2264VQI is strongly affected by the PCB layout. Extra care should be taken by users during design process to ensure that the IC will operate under the recommended environmental conditions.

## Layout Considerations

Several layout tips are listed below for the best electric and thermal performance.

1. Connected a small copper plane to LX pin to have lower noise interference area.
2. The IN pins and pad are connected to internal high side switch drain. They are also low resistance thermal conduction path. Connected a large copper plane to IN pins to help thermal dissipation.
3. Input capacitors should be connected to the IN pin and the PGND pin as close as possible to reduce the switching spikes.
4. Decoupling capacitor  $C_{VCC}$  should be connected to  $V_{CC}$  and AGND as close as possible.
5. Keep sensitive signal traces such as output trace far away from the LX pins.
6. Let VID0, VID1, and MODE\_SET pin to use AGND
7. Pour copper plane on all unused board area and connect it to stable DC nodes, like VIN, GND or VOUT.

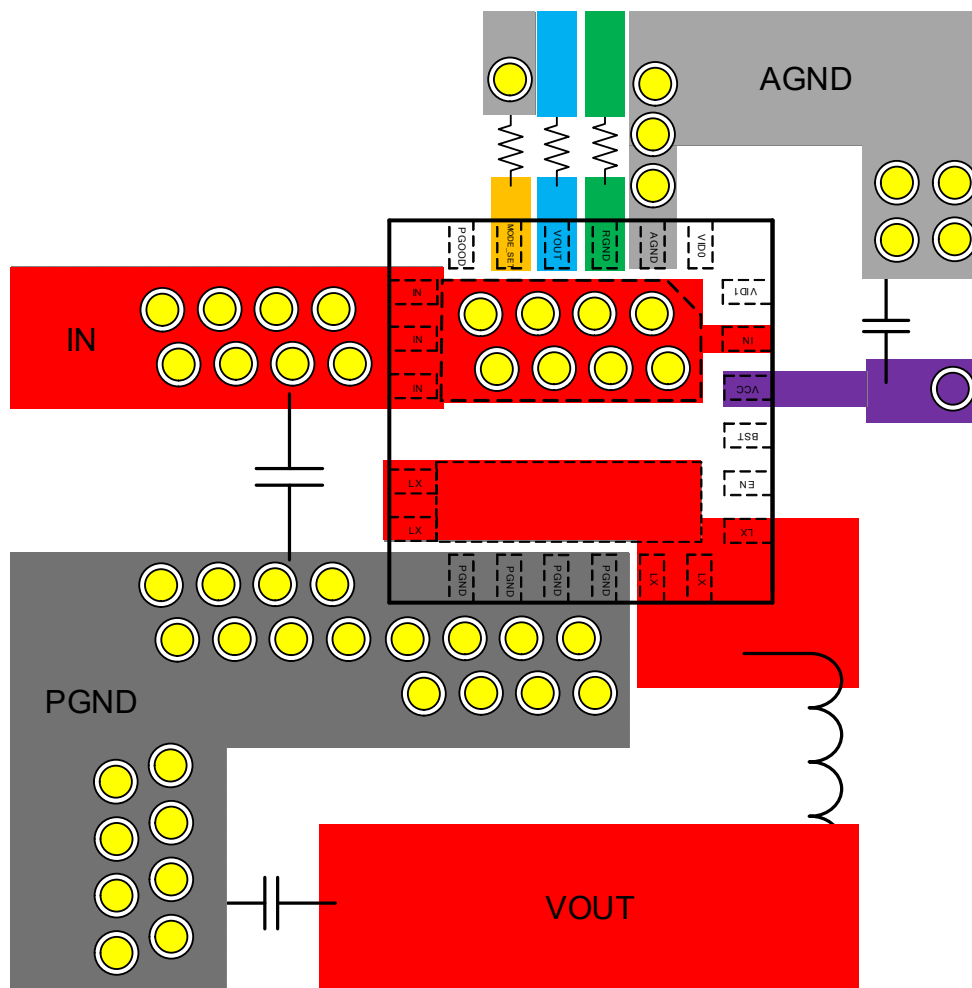



Package Dimensions, QFN 4x4-23L

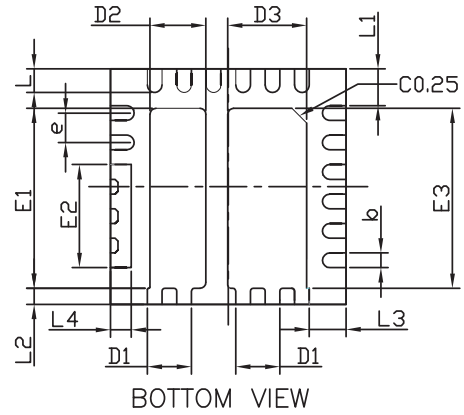
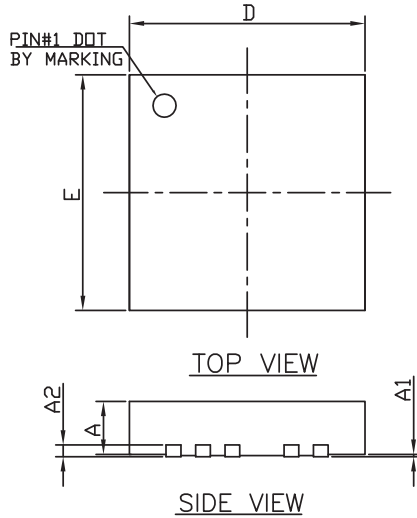

RECOMMENDED LAND PATTERN

Option 1

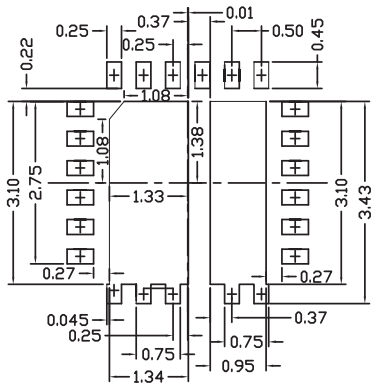

Option 2

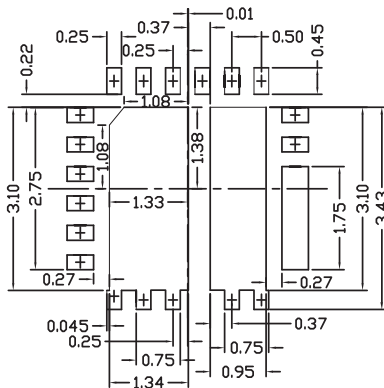

SYMBOLS	DIMENSIONS IN MILLIMETERS			DIMENSIONS IN INCHES		
	MIN	NOM	MAX	MIN	NOM	MAX
A	0.80	0.90	1.00	0.031	0.035	0.039
A1	0.00	—	0.05	0.000	—	0.002
A2	0.2 REF			0.008 REF		
E	3.90	4.00	4.10	0.153	0.157	0.161
E1	2.95	3.05	3.15	0.116	0.120	0.124
E2	1.65	1.75	1.85	0.065	0.069	0.073
E3	2.95	3.05	3.15	0.116	0.120	0.124
D	3.90	4.00	4.10	0.153	0.157	0.161
D1	0.65	0.75	0.85	0.026	0.030	0.034
D2	0.85	0.95	1.05	0.033	0.037	0.041
D3	1.24	1.34	1.44	0.049	0.053	0.057
L	0.35	0.40	0.45	0.014	0.016	0.018
L1	0.57	0.62	0.67	0.022	0.024	0.026
L2	0.23	0.28	0.33	0.009	0.011	0.013
L3	0.57	0.62	0.67	0.022	0.024	0.026
L4	0.30	0.35	0.40	0.012	0.014	0.016
b	0.20	0.25	0.30	0.008	0.010	0.012
e	0.50 BSC			0.020 BSC		

UNIT: mm

NOTE

1. CONTROLLING DIMENSION IS MILLIMETER.  
CONVERTED INCH DIMENSIONS ARE NOT NECESSARILY EXACT.
2. TOLERANCE :±0.05 UNLESS OTHERWISE SPECIFIED.
3. RADIUS ON ALL CORNER ARE 0.152 MAX., UNLESS OTHERWISE SPECIFIED.
4. PACKAGE WARPAGE: 0.012 MAX.
5. NO ANY PLASTIC FLASH ALLOWED ON THE TOP AND BOTTOM LEAD SURFACE.
6. PAD PLANARITY: ±0.102
7. CRACK BETWEEN PLASTIC BODY AND LEAD IS NOT ALLOWED.

### Tape and Reel Dimensions, QFN 4x4-23L

#### QFN4x4 Carrier Tape

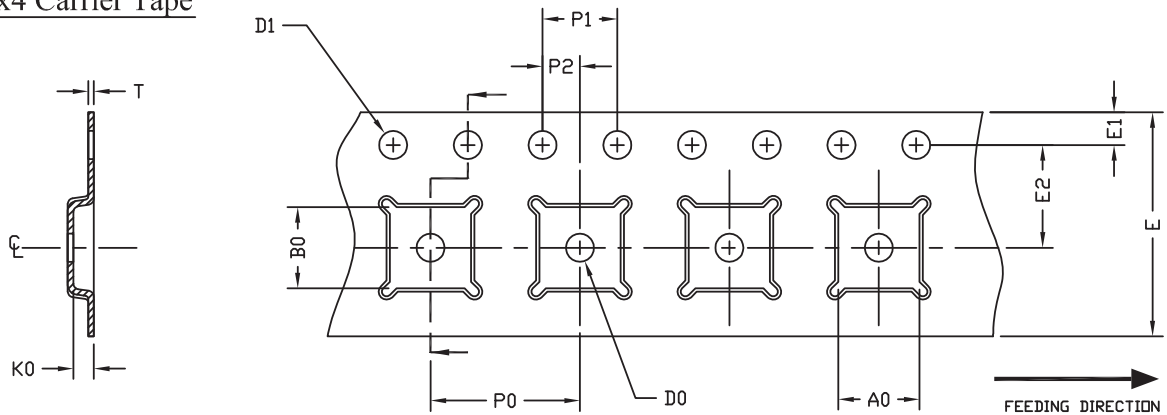

UNIT: MM

PACKAGE	A0	B0	K0	D0	D1	E	E1	E2	P0	P1	P2	T
QFN4x4 (12 mm)	4.35 ±0.10	4.35 ±0.10	1.10 ±0.10	1.50 MIN.	1.50 +0.1 -0.0	12.0 ±0.3	1.75 ±0.10	5.50 ±0.05	8.00 ±0.10	4.00 ±0.10	2.00 ±0.05	0.30 ±0.05

#### QFN4x4 Reel

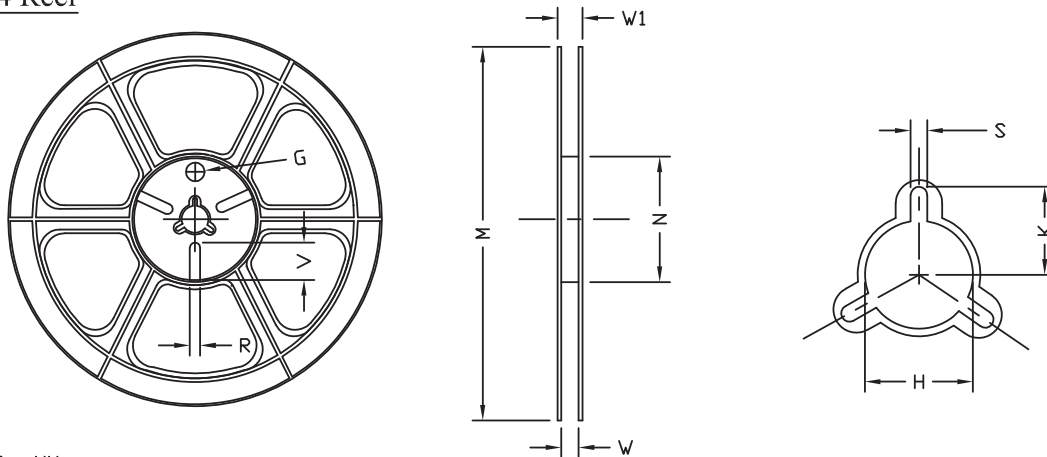

UNIT: MM

TAPE SIZE	REEL SIZE	M	N	W	W1	H	K	S	G	R	V
12 mm	ø330	ø330.0 ±2.0	ø79.0 ±1.0	12.4 +2.0 -0.0	17.0 +2.0 -1.2	ø13.0 ±0.5	10.5 ±0.2	2.0 ±0.5	---	---	---

#### QFN4x4 Tape

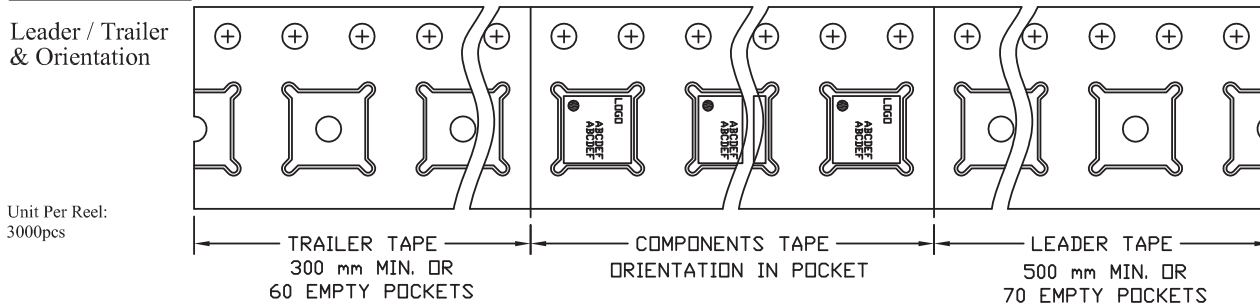

Unit Per Reel:  
3000pcs

## Part Marking

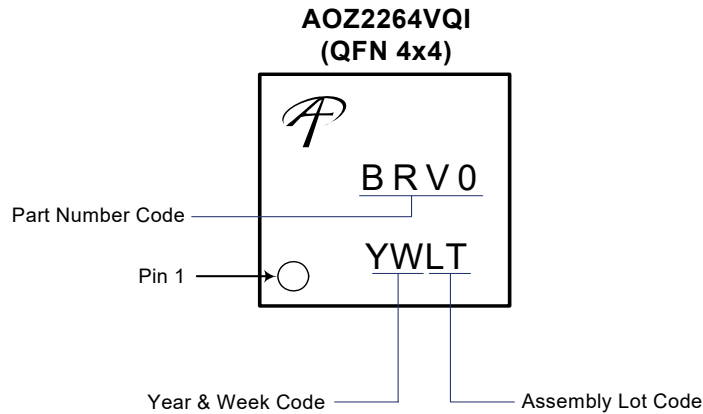

**Note:**

Assembly Location – YWLT/YWLT/YWLT

### LEGAL DISCLAIMER

Applications or uses as critical components in life support devices or systems are not authorized. AOS does not assume any liability arising out of such applications or uses of its products. AOS reserves the right to make changes to product specifications without notice. It is the responsibility of the customer to evaluate suitability of the product for their intended application. Customer shall comply with applicable legal requirements, including all applicable export control rules, regulations and limitations.

AOS' products are provided subject to AOS' terms and conditions of sale which are set forth at:

[http://www.aosmd.com/terms\\_and\\_conditions\\_of\\_sale](http://www.aosmd.com/terms_and_conditions_of_sale)

### LIFE SUPPORT POLICY

ALPHA AND OMEGA SEMICONDUCTOR PRODUCTS ARE NOT AUTHORIZED FOR USE AS CRITICAL COMPONENTS IN LIFE SUPPORT DEVICES OR SYSTEMS.

As used herein:

- |   |   |
|---|---|
| <p>1. Life support devices or systems are devices or systems which, (a) are intended for surgical implant into the body or (b) support or sustain life, and (c) whose failure to perform when properly used in accordance with instructions for use provided in the labeling, can be reasonably expected to result in a significant injury of the user.</p> | <p>2. A critical component in any component of a life support, device, or system whose failure to perform can be reasonably expected to cause the failure of the life support device or system, or to affect its safety or effectiveness.</p> |
|---|---|