

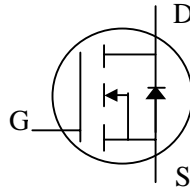

**N-channel Enhancement-mode Power MOSFET**

- Simple Drive Requirement**
- 100% Avalanche Tested**
- Fast Switching Performance**
- RoHS-compliant, halogen-free**



|              |       |
|--------------|-------|
| $BV_{DSS}$   | 650V  |
| $R_{DS(ON)}$ | 0.75Ω |
| $I_D$        | 9A    |

**Description**

Advanced Power MOSFETs from APEC provide the designer with the best combination of fast switching, low on-resistance and cost-effectiveness.

The AP09N70P-A-HF-3 is in the popular TO-220 through-hole package which is widely used in commercial and industrial applications where a small PCB footprint or an attached heatsink is required.

This device is well suited for use in high voltage applications such as off-line AC/DC converters.

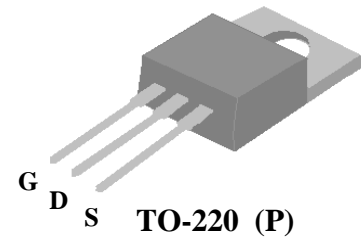

**Absolute Maximum Ratings**

| Symbol                      | Parameter                                  | Rating     | Units |
|-----------------------------|--|------------|-------|
| $V_{DS}$                    | Drain-Source Voltage                       | 650        | V     |
| $V_{GS}$                    | Gate-Source Voltage                        | ±30        | V     |
| $I_D$ at $T_C=25^{\circ}C$  | Continuous Drain Current <sup>3</sup>      | 9          | A     |
| $I_D$ at $T_C=100^{\circ}C$ | Continuous Drain Current <sup>3</sup>      | 5          | A     |
| $I_{DM}$                    | Pulsed Drain Current <sup>1</sup>          | 40         | A     |
| $P_D$ at $T_C=25^{\circ}C$  | Total Power Dissipation                    | 156        | W     |
|                             | Linear Derating Factor                     | 1.25       | W/°C  |
| $E_{AS}$                    | Single Pulse Avalanche Energy <sup>2</sup> | 305        | mJ    |
| $I_{AR}$                    | Avalanche Current                          | 9          | A     |
| $E_{AR}$                    | Repetitive Avalanche Energy                | 9          | mJ    |
| $T_{STG}$                   | Storage Temperature Range                  | -55 to 150 | °C    |
| $T_J$                       | Operating Junction Temperature Range       | -55 to 150 | °C    |

**Thermal Data**

| Symbol | Parameter                                    | Value | Unit |
|--------|--|-------|------|
| Rthj-c | Maximum Thermal Resistance, Junction-case    | 0.8   | °C/W |
| Rthj-a | Maximum Thermal Resistance, Junction-ambient | 62    | °C/W |

**Ordering Information**

**AP09N70P-A-HF-3TB    RoHS-compliant halogen-free TO-220, shipped in tubes**



**Electrical Specifications at  $T_j=25^\circ\text{C}$  (unless otherwise specified)**

| Symbol                       | Parameter  | Test Conditions                             | Min. | Typ. | Max.      | Units               |
|------------------------------|--|---|------|------|-----------|---------------------|
| $BV_{DSS}$                   | Drain-Source Breakdown Voltage                           | $V_{GS}=0V, I_D=1mA$                        | 650  | -    | -         | V                   |
| $\Delta BV_{DSS}/\Delta T_j$ | Breakdown Voltage Temperature Coefficient                | Reference to $25^\circ\text{C}$ , $I_D=1mA$ | -    | 0.6  | -         | V/ $^\circ\text{C}$ |
| $R_{DS(ON)}$                 | Static Drain-Source On-Resistance <sup>3</sup>           | $V_{GS}=10V, I_D=4.5A$                      | -    | -    | 0.75      | $\Omega$            |
| $V_{GS(th)}$                 | Gate Threshold Voltage                                   | $V_{DS}=V_{GS}, I_D=250\mu A$               | 2    | -    | 4         | V                   |
| $g_{fs}$                     | Forward Transconductance                                 | $V_{DS}=10V, I_D=4.5A$                      | -    | 4.5  | -         | S                   |
| $I_{DSS}$                    | Drain-Source Leakage Current                             | $V_{DS}=600V, V_{GS}=0V$                    | -    | -    | 10        | $\mu A$             |
|                              | Drain-Source Leakage Current ( $T_j=125^\circ\text{C}$ ) | $V_{DS}=480V, V_{GS}=0V$                    | -    | -    | 100       | $\mu A$             |
| $I_{GSS}$                    | Gate-Source Leakage                                      | $V_{GS}=\pm 30V, V_{DS}=0V$                 | -    | -    | $\pm 100$ | nA                  |
| $Q_g$                        | Total Gate Charge <sup>3</sup>                           | $I_D=9A$                                    | -    | 44   | -         | nC                  |
| $Q_{gs}$                     | Gate-Source Charge                                       | $V_{DS}=480V$                               | -    | 11   | -         | nC                  |
| $Q_{gd}$                     | Gate-Drain ("Miller") Charge                             | $V_{GS}=10V$                                | -    | 12   | -         | nC                  |
| $t_{d(on)}$                  | Turn-on Delay Time <sup>3</sup>                          | $V_{DD}=300V$                               | -    | 19   | -         | ns                  |
| $t_r$                        | Rise Time  | $I_D=9A$                                    | -    | 21   | -         | ns                  |
| $t_{d(off)}$                 | Turn-off Delay Time                                      | $R_G=10\Omega, V_{GS}=10V$                  | -    | 56   | -         | ns                  |
| $t_f$                        | Fall Time  | $R_D=34\Omega$                              | -    | 24   | -         | ns                  |
| $C_{iss}$                    | Input Capacitance  | $V_{GS}=0V$                                 | -    | 2660 | -         | pF                  |
| $C_{oss}$                    | Output Capacitance                                       | $V_{DS}=25V$                                | -    | 170  | -         | pF                  |
| $C_{rss}$                    | Reverse Transfer Capacitance                             | $f=1.0MHz$                                  | -    | 10   | -         | pF                  |

**Source-Drain Diode**

| Symbol   | Parameter                                       | Test Conditions                           | Min. | Typ. | Max. | Units |
|----------|---|---|------|------|------|-------|
| $I_S$    | Continuous Source Current (Body Diode)          | $V_D=V_G=0V, V_S=1.5V$                    | -    | -    | 9    | A     |
| $I_{SM}$ | Pulsed Source Current (Body Diode) <sup>1</sup> |   | -    | -    | 40   | A     |
| $V_{SD}$ | Forward On Voltage <sup>3</sup>                 | $T_j=25^\circ\text{C}, I_S=9A, V_{GS}=0V$ | -    | -    | 1.5  | V     |

**Notes:**

1. Pulse width limited by maximum junction temperature.
2. Starting  $T_j=25^\circ\text{C}$ ,  $V_{DD}=50V$ ,  $L=6.8mH$ ,  $R_G=25\Omega$ ,  $I_{AS}=9A$ .
3. Pulse test - pulse width  $\leq 300\mu s$ , duty cycle  $\leq 2\%$

THIS PRODUCT IS SENSITIVE TO ELECTROSTATIC DISCHARGE, PLEASE HANDLE WITH CAUTION.

USE OF THIS PRODUCT AS A CRITICAL COMPONENT IN LIFE SUPPORT OR OTHER SIMILAR SYSTEMS IS NOT AUTHORIZED.

APEC DOES NOT ASSUME ANY LIABILITY ARISING OUT OF THE APPLICATION OR USE OF ANY PRODUCT OR CIRCUIT DESCRIBED HEREIN; NEITHER DOES IT CONVEY ANY LICENSE UNDER ITS PATENT RIGHTS, NOR THE RIGHTS OF OTHERS.

APEC RESERVES THE RIGHT TO MAKE CHANGES WITHOUT FURTHER NOTICE TO ANY PRODUCTS HEREIN TO IMPROVE RELIABILITY, FUNCTION OR DESIGN.



Typical Electrical Characteristics

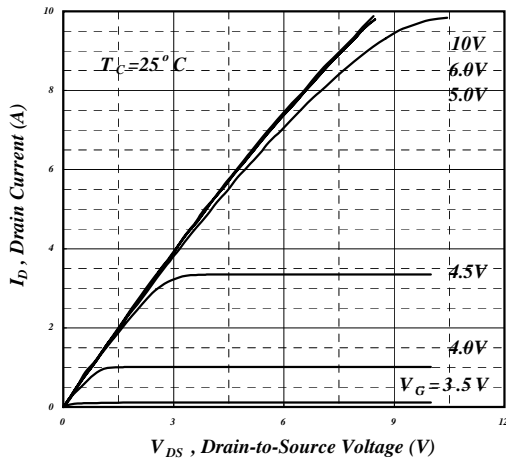

Fig 1. Typical Output Characteristics

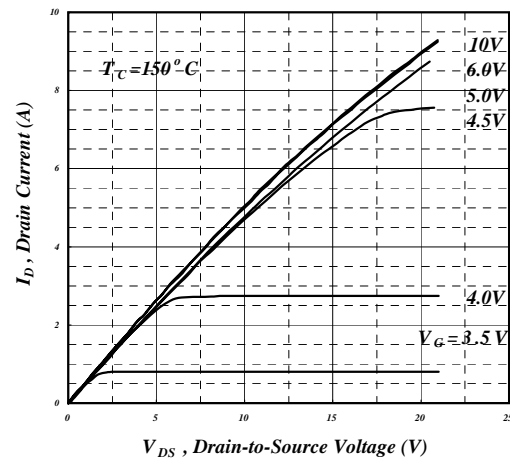

Fig 2. Typical Output Characteristics

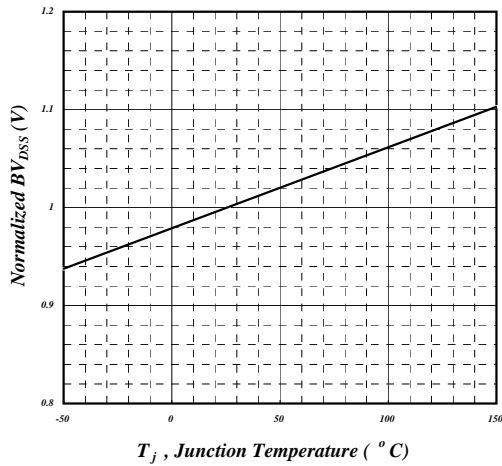

Fig 3. Normalized  $BV_{DSS}$  vs. Junction Temperature

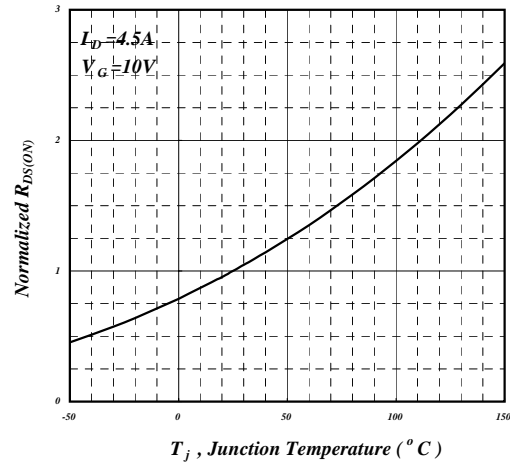

Fig 4. Normalized On-Resistance vs. Junction Temperature

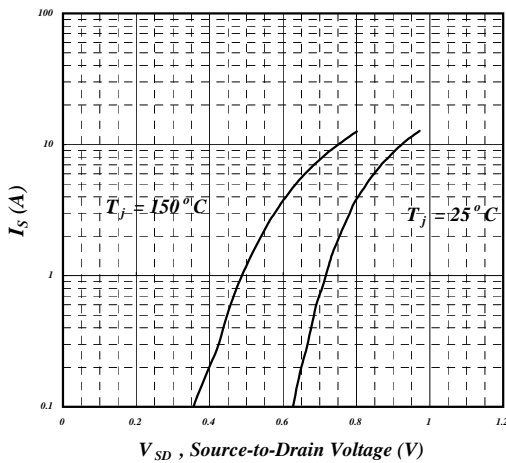

Fig 5. Forward Characteristic of Reverse Diode

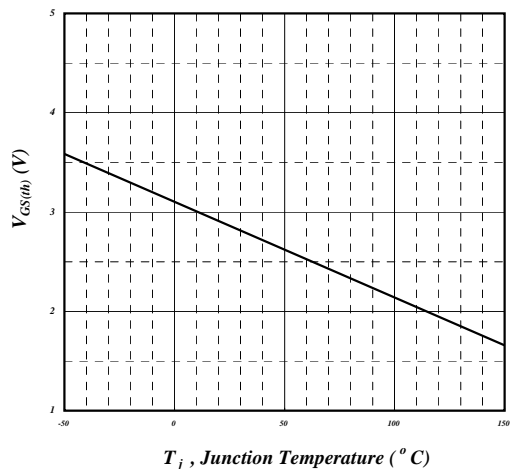

Fig 6. Gate Threshold Voltage vs. Junction Temperature



Typical Electrical Characteristics (cont.)

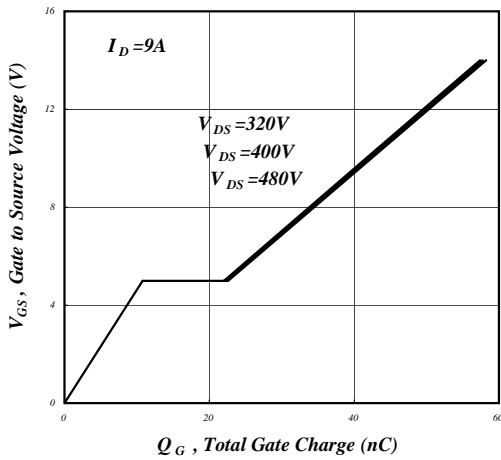

Fig 7. Gate Charge Characteristics

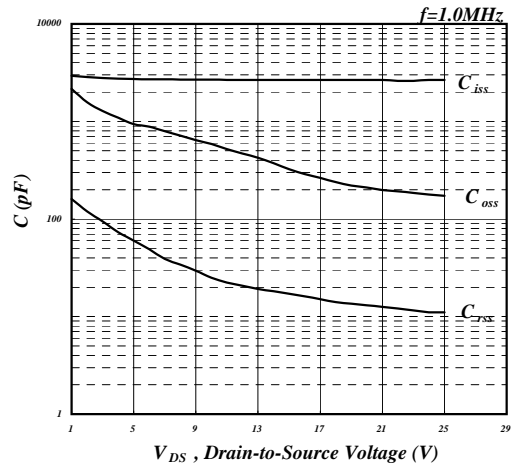

Fig 8. Typical Capacitance Characteristics

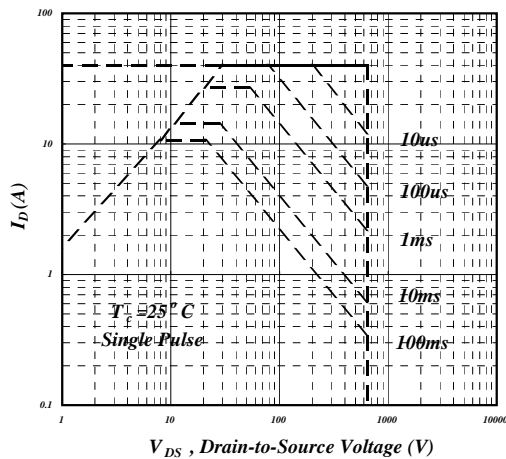

Fig 9. Maximum Safe Operating Area

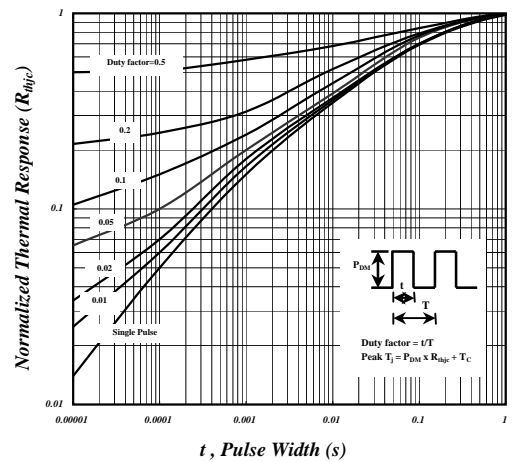

Fig 10. Effective Transient Thermal Impedance

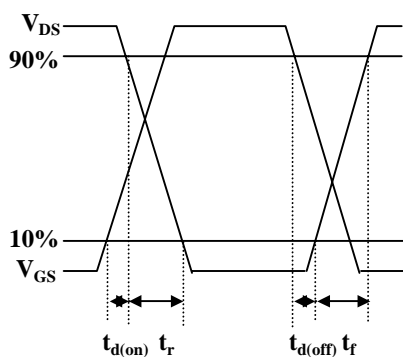

Fig 11. Switching Time Waveforms

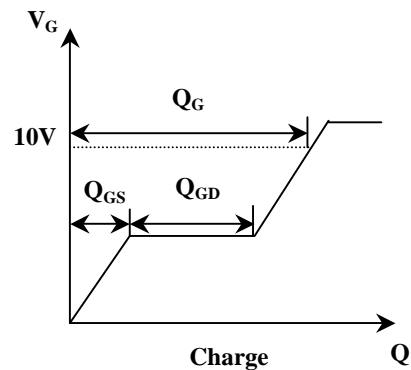
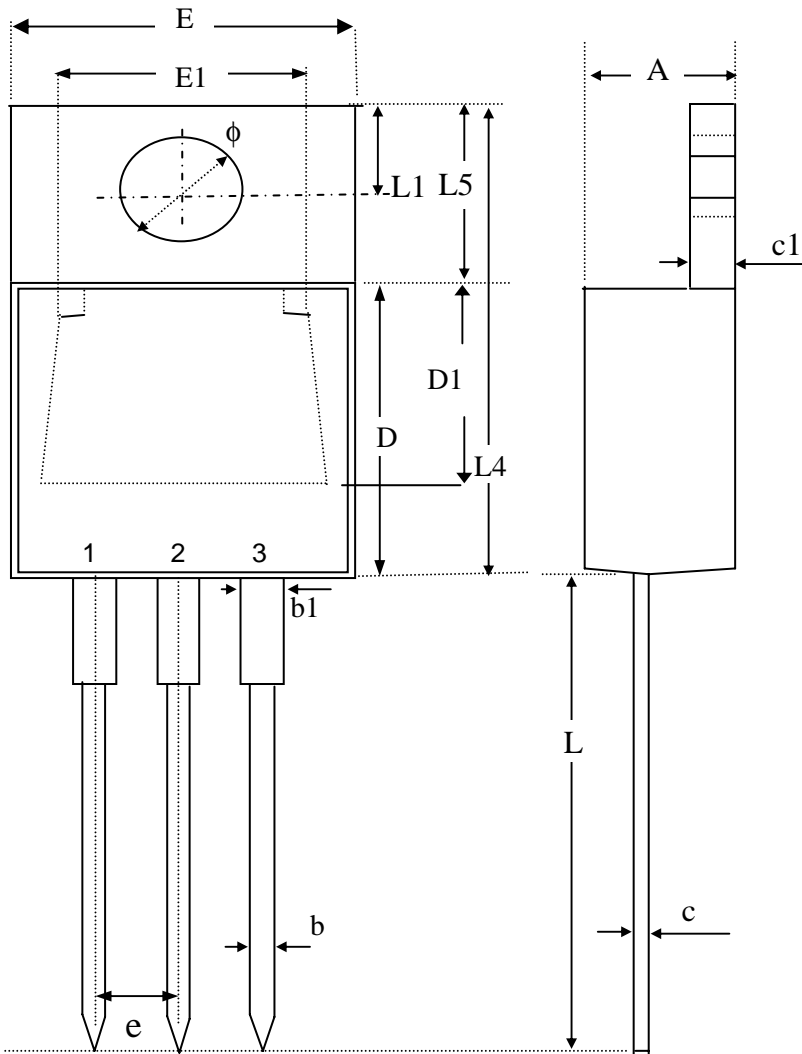

Fig 12. Gate Charge Waveform



**Package Dimensions: TO-220**



| SYMBOLS | Millimeters |       |       |
|---------|-------------|-------|-------|
|         | MIN         | NOM   | MAX   |
| A       | 4.40        | 4.60  | 4.80  |
| b       | 0.76        | 0.88  | 1.00  |
| D       | 8.60        | 8.80  | 9.00  |
| c       | 0.36        | 0.43  | 0.50  |
| E       | 9.80        | 10.10 | 10.40 |
| L4      | 14.70       | 15.00 | 15.30 |
| L5      | 6.20        | 6.40  | 6.60  |
| D1      | 5.10 REF.   |       |       |
| c1      | 1.25        | 1.35  | 1.45  |
| b1      | 1.17        | 1.32  | 1.47  |
| L       | 13.25       | 13.75 | 14.25 |
| e       | 2.54 REF.   |       |       |
| L1      | 2.60        | 2.75  | 2.89  |
| phi     | 3.71        | 3.84  | 3.96  |
| E1      | 7.4 REF.    |       |       |

1. All dimensions are in millimeters.
2. Dimensions do not include mold protrusions.

**Marking Information: TO-220**

