

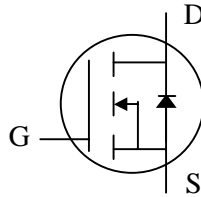

N-channel Enhancement-mode Power MOSFET

- Lead(Pb)-free, Halogen-free
- Low Conductance Losses
- Fast Switching Performance
- Low Profile (< 0.7mm)



BV_{DSS}	30V
$R_{DS(ON)}$	4.5mΩ
I_D	17.3A

Description

The AP1003BST-3 uses the latest APEC Power MOSFET silicon technology with advanced technology GreenFET™ packaging to provide the lowest on-resistance, a low profile and dual-sided cooling capability.

The GreenFET™ package is compatible with existing soldering techniques and is ideal for power applications, especially for high-frequency/high-efficiency DC-DC converters.

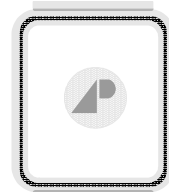

GreenFET™

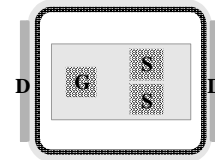

ST

Absolute Maximum Ratings

Symbol	Parameter	Rating	Units
V_{DS}	Drain-Source Voltage	30	V
V_{GS}	Gate-Source Voltage	±20	V
I_D at $T_A=25^\circ C$	Continuous Drain Current ³	17.3	A
I_D at $T_A=70^\circ C$	Continuous Drain Current ³	14.3	A
I_D at $T_C=25^\circ C$	Continuous Drain Current ⁴	75	A
I_{DM}	Pulsed Drain Current ¹	150	A
P_D at $T_A=25^\circ C$	Total Power Dissipation ³	2.2	W
P_D at $T_A=70^\circ C$	Total Power Dissipation ³	1.4	W
P_D at $T_C=25^\circ C$	Total Power Dissipation ⁴	42	W
E_{AS}	Single Pulse Avalanche Energy ⁵	28.8	mJ
I_{AR}	Avalanche Current	24	A
T_{STG}	Storage Temperature Range	-40 to 150	°C
T_J	Operating Junction Temperature Range	-40 to 150	°C

Thermal Data

Rthj-c	Maximum Thermal Resistance, Junction-case ⁴	3	°C/W
Rthj-a	Maximum Thermal Resistance, Junction-ambient ³	58	°C/W

Ordering Information

AP1003BST-3TR RoHS-compliant halogen-free GreenFET™ ST package, shipped on tape and reel (4800 pcs/reel)



Electrical Specifications at $T_j=25^\circ\text{C}$ (unless otherwise specified)

Symbol	Parameter	Test Conditions	Min.	Typ.	Max.	Units
BV_{DSS}	Drain-Source Breakdown Voltage	$V_{GS}=0V, I_D=250\mu A$	30	-	-	V
$R_{DS(ON)}$	Static Drain-Source On-Resistance ²	$V_{GS}=10V, I_D=13A$	-	3.6	4.5	m Ω
		$V_{GS}=4.5V, I_D=11A$	-	5.2	6.5	m Ω
$V_{GS(th)}$	Gate Threshold Voltage	$V_{DS}=V_{GS}, I_D=250\mu A$	1.35	-	2.35	V
g_{fs}	Forward Transconductance	$V_{DS}=10V, I_D=11A$	13	23	-	S
I_{DSS}	Drain-Source Leakage Current	$V_{DS}=24V, V_{GS}=0V$	-	-	1	μA
	Drain-Source Leakage Current ($T_j=125^\circ\text{C}$)	$V_{DS}=24V, V_{GS}=0V$	-	-	150	μA
I_{GSS}	Gate-Source Leakage	$V_{GS}=\pm 20V, V_{DS}=0V$	-	-	± 100	nA
Q_g	Total Gate Charge ²	$I_D=11A$	-	12	19.2	nC
Q_{gs}	Gate-Source Charge	$V_{DS}=15V$	-	3	-	nC
Q_{gd}	Gate-Drain ("Miller") Charge	$V_{GS}=4.5V$	-	6	-	nC
$t_{d(on)}$	Turn-on Delay Time ²	$V_{DS}=16V$	-	10	-	ns
t_r	Rise Time	$I_D=11A$	-	41	-	ns
$t_{d(off)}$	Turn-off Delay Time	$R_G=3.3\Omega, V_{GS}=10V$	-	22	-	ns
t_f	Fall Time	$R_D=1.45\Omega$	-	7.6	-	ns
	Input Capacitance	$V_{GS}=0V$	-	1155	1850	pF
C_{OSS}	Output Capacitance	$V_{DS}=25V$	-	400	-	pF
C_{rss}	Reverse Transfer Capacitance	$f=1.0\text{MHz}$	-	170	-	pF
R_g	Gate Resistance	$f=1.0\text{MHz}$	-	1.1	2	Ω

Source-Drain Diode

Symbol	Parameter	Test Conditions	Min.	Typ.	Max.	Units
I_S	Continuous Source Current (Body Diode)		-	-	52	A
I_{SM}	Pulsed Source Current (Body Diode) ¹		-	-	110	A
V_{SD}	Forward On Voltage ²	$I_S=11A, V_{GS}=0V$	-	0.82	1	V
t_{rr}	Reverse Recovery Time	$I_S=11A, V_{GS}=0V,$	-	32	48	ns
Q_{rr}	Reverse Recovery Charge	$di/dt=100A/\mu s$	-	26	39	nC

Notes:

1. Pulse width limited by maximum junction temperature.
2. Pulse test
3. Surface mounted on 1 in² copper pad of FR4 board.
4. T_C measured with thermocouple mounted to top (Drain) of part.
5. Starting $T_j=25^\circ\text{C}$, $L=0.1\text{mH}$, $R_G=25\Omega$

THIS PRODUCT IS SENSITIVE TO ELECTROSTATIC DISCHARGE, PLEASE HANDLE WITH CAUTION.

USE OF THIS PRODUCT AS A CRITICAL COMPONENT IN LIFE SUPPORT OR OTHER SIMILAR SYSTEMS IS NOT AUTHORIZED.

APEC DOES NOT ASSUME ANY LIABILITY ARISING OUT OF THE APPLICATION OR USE OF ANY PRODUCT OR CIRCUIT DESCRIBED HEREIN; NEITHER DOES IT CONVEY ANY LICENSE UNDER ITS PATENT RIGHTS, NOR THE RIGHTS OF OTHERS.

APEC RESERVES THE RIGHT TO MAKE CHANGES WITHOUT FURTHER NOTICE TO ANY PRODUCTS HEREIN TO IMPROVE RELIABILITY, FUNCTION OR DESIGN.



Typical Electrical Characteristics

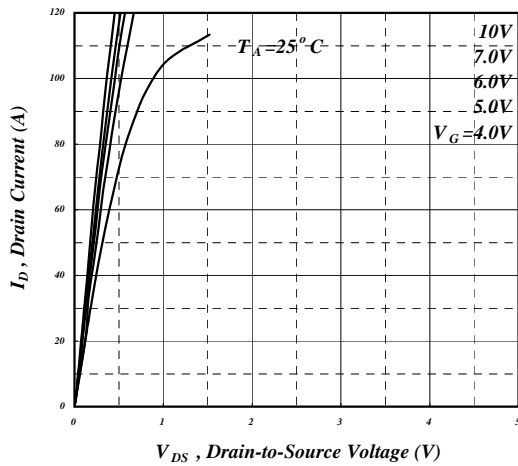

Fig 1. Typical Output Characteristics

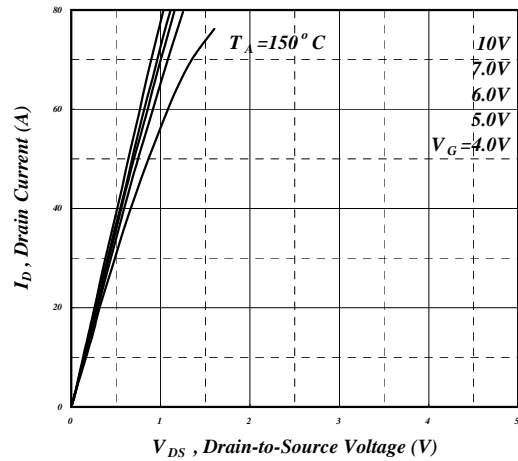

Fig 2. Typical Output Characteristics

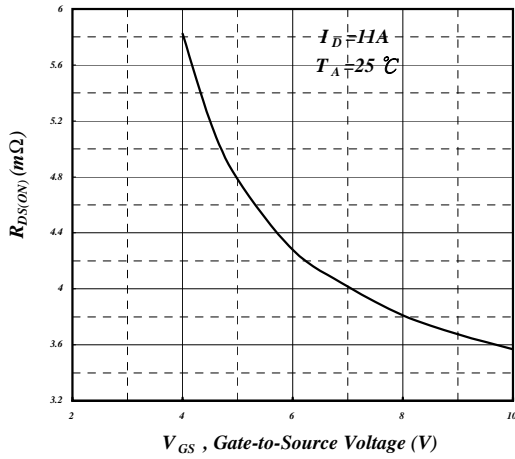

Fig 3. On-Resistance vs. Gate Voltage

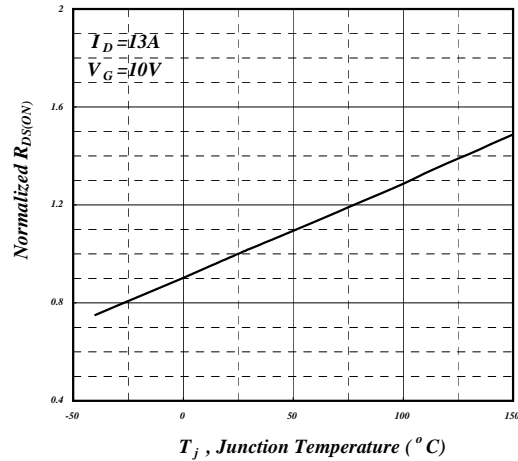

Fig 4. Normalized On-Resistance vs. Junction Temperature

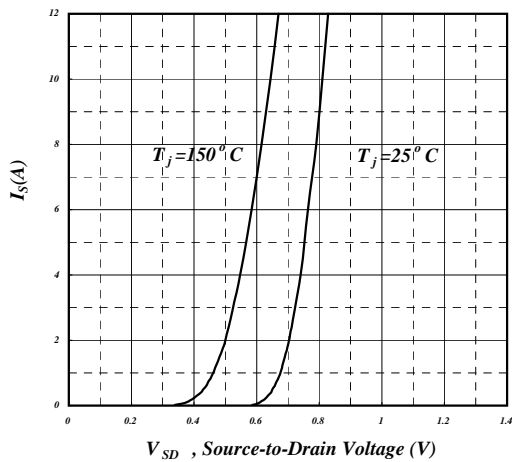

Fig 5. Forward Characteristic of Reverse Diode

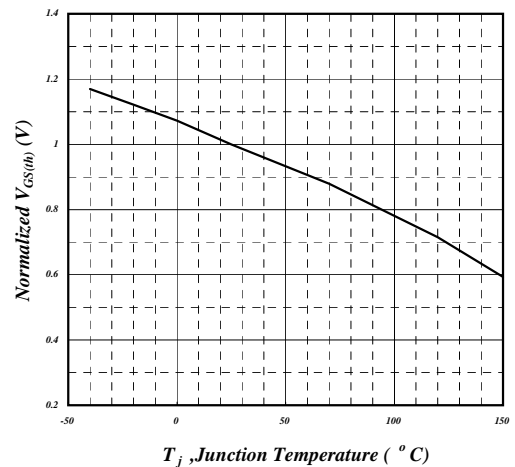

Fig 6. Gate Threshold Voltage vs. Junction Temperature



Typical Electrical Characteristics (cont.)

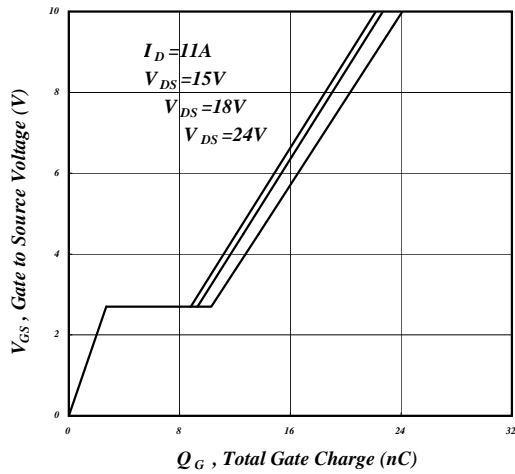

Fig 7. Gate Charge Characteristics

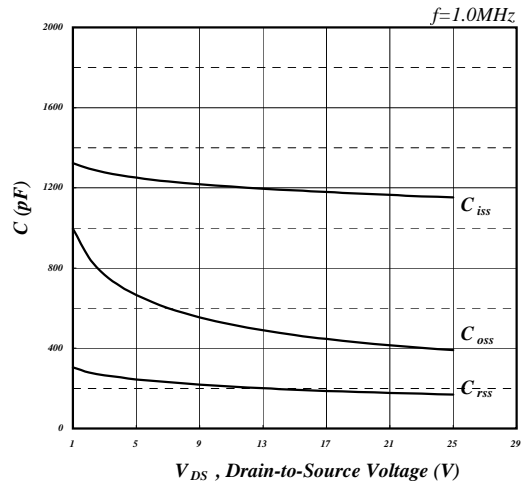

Fig 8. Typical Capacitance Characteristics

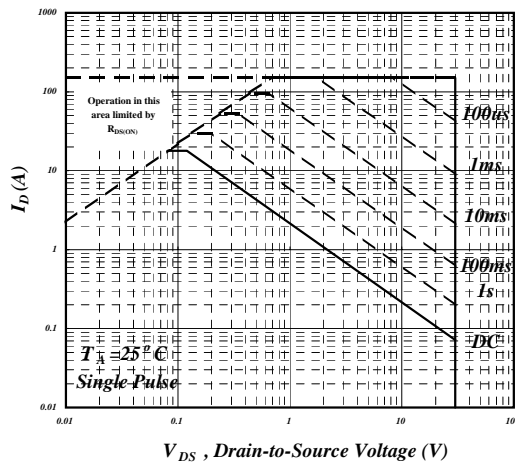

Fig 9. Maximum Safe Operating Area

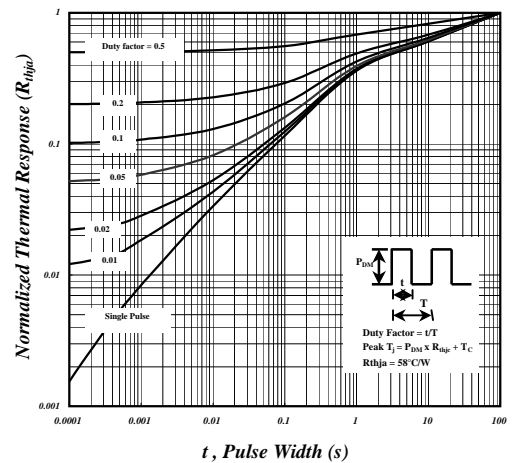

Fig 10. Effective Transient Thermal Impedance

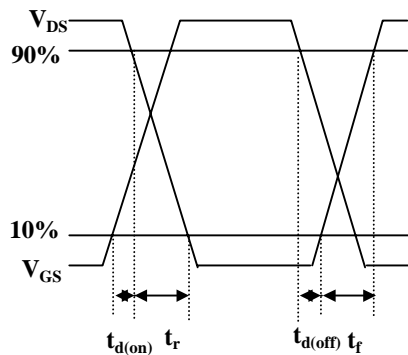

Fig 11. Switching Time Waveform

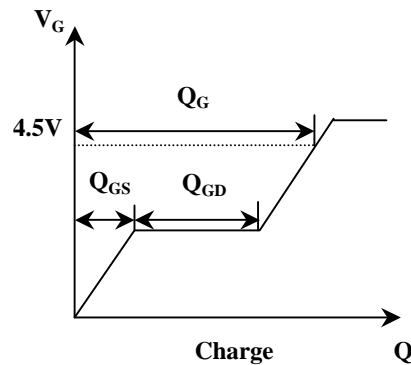
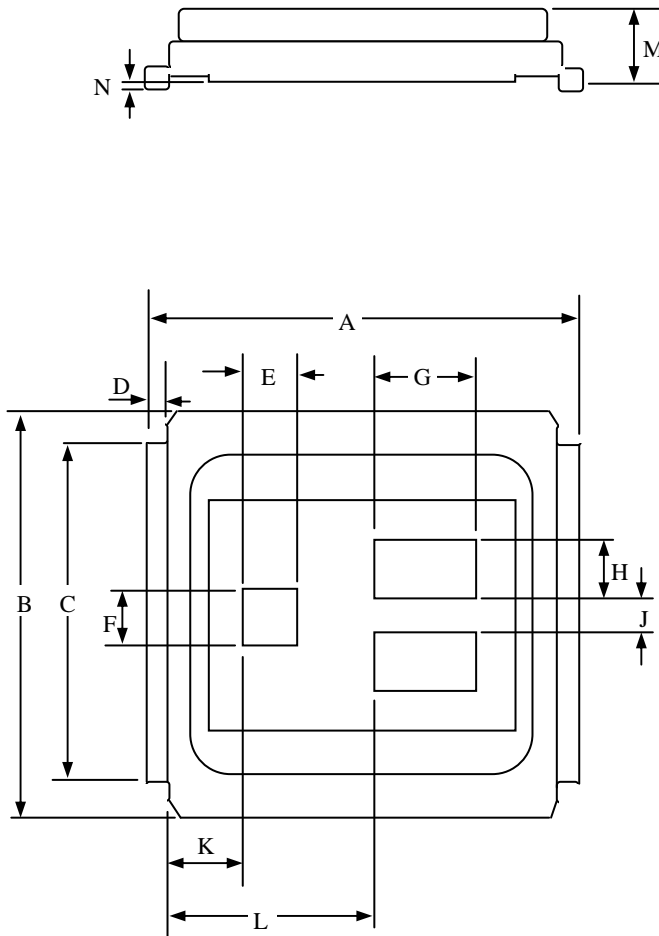

Fig 12. Gate Charge Waveform



Package Dimensions: Small Size Can ST



SYMBOLS	Millimeters		
	MIN	NOM	MAX
A	4.75	4.80	4.85
B	3.70	3.83	3.95
C	2.75	2.80	2.85
D	0.35	0.40	0.45
E	0.58	0.60	0.62
F	0.58	0.60	0.62
G	0.75	0.77	0.79
H	0.53	0.55	0.57
J	0.26	0.28	0.30
K	0.88	0.93	0.98
L	2.18	2.23	2.28
M	0.48	0.53	0.58
N	0.03	0.06	0.08

1. All dimensions are in millimeters.
2. For information on solder stencil and substrate design, please contact APEC at support@a-powerusa.com

Marking Information:

Laser Marking

