

Description

AP1117 is a low dropout positive adjustable or fixed-mode regulator with 1A output current capability. The product is voltage specifically designed to provide well-regulated supply for low IC applications such as high-speed bus termination and low current 3.3V logic supply. AP1117 is also well suited for other applications such as VGA cards. AP1117 is guaranteed to have lower than 1.4V dropout at full load current making it ideal to provide well-regulated outputs of 1.25 to 5.0 with 6.4V to 18V input supply. AP1117 is available in commercial temperature grade.

Features

- 1.4V Maximum Dropout at Full Load Current
- Fast Transient Response
- Output Current Limiting
- Built-in Thermal Shutdown
- Good Noise Rejection
- 3-Terminal Adjustable or Fixed 1.5V, 1.8V, 2.5V, 3.3V, 5.0V
- Lead Free Packages: SOT223-3L, TO252-3L, SOT89-3L, TO263-3L and TO220-3L
- SOT223-3L, TO252-3L, SOT89-3L, TO263-3L and TO220-3L: Available in "Green" Molding Compound (No Br, Sb)
- Lead Free Finish/RoHS Compliant (Note 1)

Applications

- PC Peripheral
- Communication

Pin Assignments

SOT89-3L

(Top View)

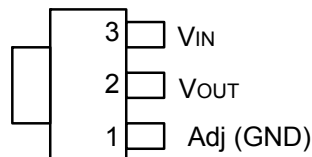

Tab is V_{OUT}

SOT223-3L

(Top View)



Tab is V_{OUT}

TO220-3L

(Front View)

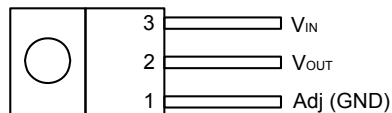

Tab is V_{OUT}

TO252-3L and TO263-3L

(Top View)

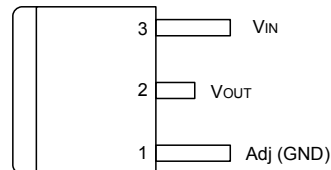

Tab is V_{OUT}

Notes: 1. EU Directive 2002/95/EC (RoHS). All applicable RoHS exemptions applied. Please visit our website at http://www.diodes.com/products/lead_free.html.

Typical Application Circuit

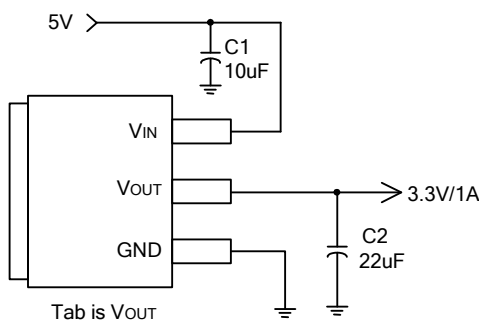

(5V/3.3V fixed output)

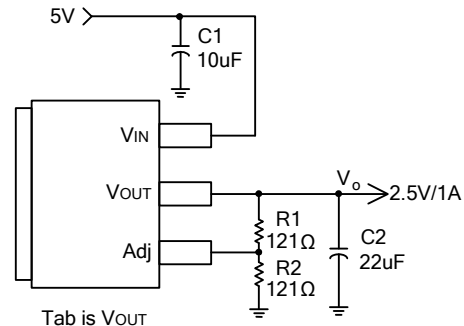

(5V/2.5V ADJ output)

Note:
$$V_o = V_{REF} \times \left(1 + \frac{R_2}{R_1}\right)$$

Pin Descriptions

| Pin Name | I/O | PIN # | Description |
|------------------|-----|-------|--|
| Adj (GND) | I | 1 | A resistor divider from this pin to the V _{OUT} pin and ground sets the output voltage (Ground only for Fixed-Mode). |
| V _{OUT} | O | 2 | The output of the regulator. A minimum of 10uF capacitor (0.15Ω ≤ ESR ≤ 20Ω) must be connected from this pin to ground to insure stability. |
| V _{IN} | I | 3 | The input pin of regulator. Typically a large storage capacitor is connected from this pin to ground to insure that the input voltage does not sag below the minimum dropout voltage during the load transient response. This pin must always be 1.3V higher than V _{OUT} in order for the device to regulate properly. |

Functional Block Diagram

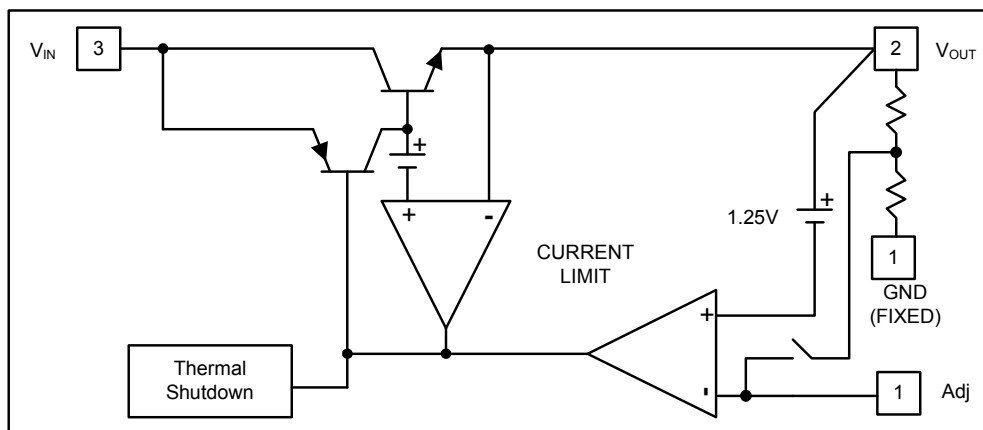

Absolute Maximum Ratings

| Symbol | Parameter | Rating | Unit |
|----------|--|---|------|
| V_{IN} | DC Supply Voltage | -0.3 to 18 | V |
| T_{MJ} | Maximum Junction Temperature | 150 | °C |
| P_D | Power Dissipation SOT89-3L SOT223-3L TO220-3L TO252-3L TO263-3L | Internally limited by maximum junction temperature of 150 °C (Note 2) | mW |
| T_{ST} | Storage Temperature | -65 to +150 | °C |

Notes: 2. AP1117 contains an internal thermal limiting circuit that is designed to protect the regulator in the event that the maximum junction temperature exceeded. When activated, typically at 150°C, the regulator output switches off and then back on as the die cools.

Recommended Operating Conditions

| Symbol | Parameter | Min | Max | Unit |
|----------|--------------------------------------|-----|-----|------|
| T_{OP} | Operating Junction Temperature Range | 0 | 125 | °C |

Electrical Characteristics (Under Operating Conditions)

| Parameter | Conditions | | Min | Typ. | Max | Unit |
|-------------------|------------|---|-------|-------|-------|------|
| Reference Voltage | AP1117-ADJ | $T_A = 25^\circ\text{C}$, $(V_{IN-OUT}) = 1.5\text{V}$ $I_O = 10\text{mA}$ | 1.225 | 1.250 | 1.275 | V |
| Output Voltage | AP1117-1.5 | $I_{OUT} = 10\text{mA}$, $T_A = 25^\circ\text{C}$, $3\text{V} \leq V_{IN} \leq 12\text{V}$ | 1.470 | 1.500 | 1.530 | V |
| | AP1117-1.8 | $I_{OUT} = 10\text{mA}$, $T_A = 25^\circ\text{C}$, $3.3\text{V} \leq V_{IN} \leq 12\text{V}$ | 1.764 | 1.800 | 1.836 | V |
| | AP1117-2.5 | $I_{OUT} = 10\text{mA}$, $T_A = 25^\circ\text{C}$, $4\text{V} \leq V_{IN} \leq 12\text{V}$ | 2.450 | 2.500 | 2.550 | V |
| | AP1117-3.3 | $I_{OUT} = 10\text{mA}$, $T_A = 25^\circ\text{C}$, $4.8\text{V} \leq V_{IN} \leq 12\text{V}$ | 3.235 | 3.300 | 3.365 | V |
| | AP1117-5.0 | $I_{OUT} = 10\text{mA}$, $T_A = 25^\circ\text{C}$, $6.5\text{V} \leq V_{IN} \leq 12\text{V}$ | 4.900 | 5.000 | 5.100 | V |
| Line Regulation | AP1117-XXX | $I_O = 10\text{mA}$, $V_{OUT} + 1.5\text{V} < V_{IN} < 12\text{V}$, $T_A = 25^\circ\text{C}$ | | | 0.2 | % |
| Load Regulation | AP1117-ADJ | $V_{IN} = 3.3\text{V}$, $V_{ADJ} = 0$, $0\text{mA} < I_O < 1\text{A}$, $T_A = 25^\circ\text{C}$ (Note 3, 4) | | | 1 | % |
| | AP1117-1.5 | $V_{IN} = 3\text{V}$, $0\text{mA} < I_O < 1\text{A}$, $T_A = 25^\circ\text{C}$ (Note 3, 4) | | 12 | 15 | mV |
| | AP1117-1.8 | $V_{IN} = 3.3\text{V}$, $0\text{mA} < I_O < 1\text{A}$, $T_A = 25^\circ\text{C}$ (Note 3, 4) | | 15 | 18 | mV |
| | AP1117-2.5 | $V_{IN} = 4\text{V}$, $0\text{mA} < I_O < 1\text{A}$, $T_A = 25^\circ\text{C}$ (Note 3, 4) | | 20 | 25 | mV |

Electrical Characteristics (Under Operating Conditions) (cont.)

| Parameter | Conditions | | Min | Typ. | Max | Unit |
|---|---|---|-----|-------|------|--------------|
| Load Regulation (cont.) | AP1117-3.3 | $V_{IN} = 5V, 0 \leq I_{OUT} \leq 1A,$ $T_A = 25^\circ C$ (Note 3, 4) | | 26 | 33 | mV |
| | AP1117-5.0 | $V_{IN} = 8V, 0 \leq I_{OUT} \leq 1A,$ $T_A = 25^\circ C$ (Note 3, 4) | | 40 | 50 | mV |
| Dropout Voltage ($V_{IN}-V_{OUT}$) | AP1117-ADJ/1.5/1.8 /2.5/3.3/5.0 | $I_{OUT} = 800mA, \Delta V_{OUT} = 1\%V_{OUT}$ $0^\circ C \leq T_J \leq 125^\circ C$ | | 1.2 | 1.3 | V |
| Dropout Voltage ($V_{IN}-V_{OUT}$) | AP1117-ADJ/1.5/1.8 /2.5/3.3/5.0 | $I_{OUT} = 1A, \Delta V_{OUT} = 1\%V_{OUT}$ $0^\circ C \leq T_J \leq 125^\circ C$ | | 1.3 | 1.4 | V |
| Current Limit | AP1117-ADJ/1.5/1.8 /2.5/3.3/5.0 | $(V_{IN}-V_{OUT}) = 5V$ | 1.1 | | | A |
| Minimum Load Current (Note 5) | AP1117-XXX | $0^\circ C \leq T_J \leq 125^\circ C$ | | 5 | 10 | mA |
| Thermal Regulation | $T_A = 25^\circ C, 30ms$ pulse | | | 0.008 | 0.04 | %/W |
| Ripple Rejection | $F = 180Hz, C_{OUT} = 25\mu F$ Tantalum, $I_{OUT} = 1A$ | | | | | |
| | AP1117-XXX | $V_{IN} = V_{OUT}+3V$ | | 60 | 70 | dB |
| Temperature Stability | $I_O = 10mA$ | | | 0.5 | | % |
| θ_{JA} Thermal Resistance Junction-to-Ambient θ_{JA} | SOT89-3L: Control Circuitry/Power Transistor (Note 6) | | | 164 | | $^\circ C/W$ |
| | SOT223-3L: Control Circuitry/Power Transistor (Note 7) | | | 107 | | |
| | TO252-3L: Control Circuitry/Power Transistor (Note 6) | | | 73 | | |
| | TO220-3L: Control Circuitry/Power Transistor (Note 6) | | | 78 | | |
| | TO263-3L: Control Circuitry/Power Transistor (Note 6) | | | 60 | | |
| θ_{JC} Thermal Resistance Junction-to-Case | SOT89-3L: Control Circuitry/Power Transistor (Note 6) | | | 42 | | $^\circ C/W$ |
| | SOT223-3L: Control Circuitry/Power Transistor (Note 7) | | | 15 | | |
| | TO252-3L: Control Circuitry/Power Transistor (Note 6) | | | 12 | | |
| | TO220-3L: Control Circuitry/Power Transistor (Note 6) | | | 3.5 | | |
| | TO263-3L: Control Circuitry/Power Transistor (Note 6) | | | 3.5 | | |

- Notes:
3. See thermal regulation specifications for changes in output voltage due to heating effects. Line and load regulation are measured at a constant junction temperature by low duty cycle pulse testing. Load regulation is measured at the output lead = 1/18" from the package.
 4. Line and load regulation are guaranteed up to the maximum power dissipation of 15W. Power dissipation is determined by the difference between input and output differential and the output current. Guaranteed maximum power dissipation will not be available over the full input/output range.
 5. Quiescent current is defined as the minimum output current required in maintaining regulation. At 12V input/output differential the device is guaranteed to regulate if the output current is greater than 10mA.
 6. Test conditions for SOT89-3L, TO220-3L, TO252-3L and TO263-3L: Devices mounted on FR-4 substrate, single sided PC board, 2oz copper, with minimum recommended pad layout, no air flow. The case point of θ_{JC} is located on the thermal tab.
 7. Test conditions for SOT223-3L: Devices mounted on FR-4 substrate, single sided PC board, 2oz copper, with 5mmx5mm thermal pad layout, no air flow. The case point of θ_{JC} is located on the thermal tab.

Typical Performance Characteristics

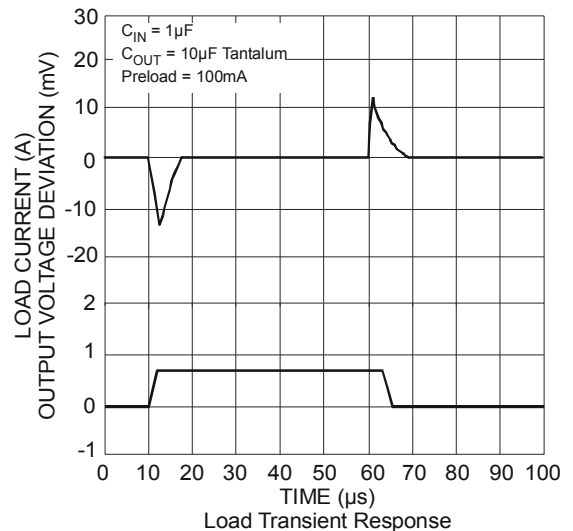
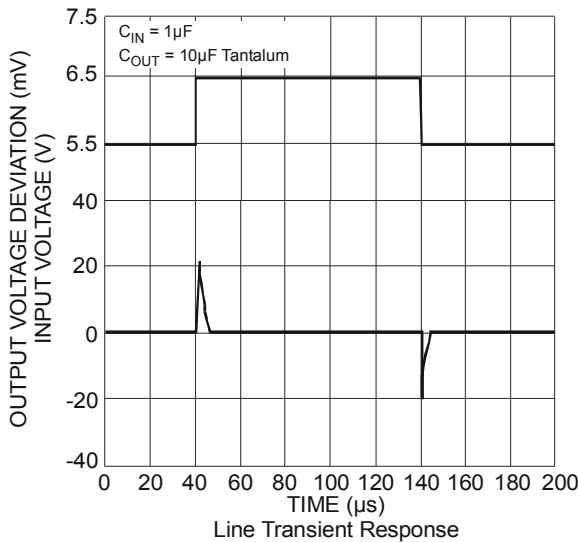
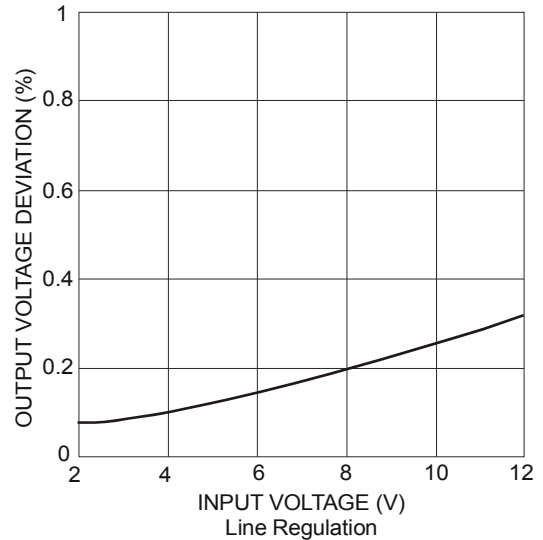
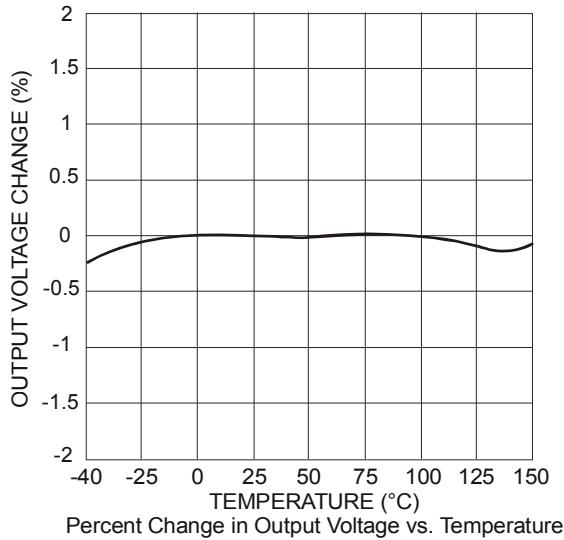
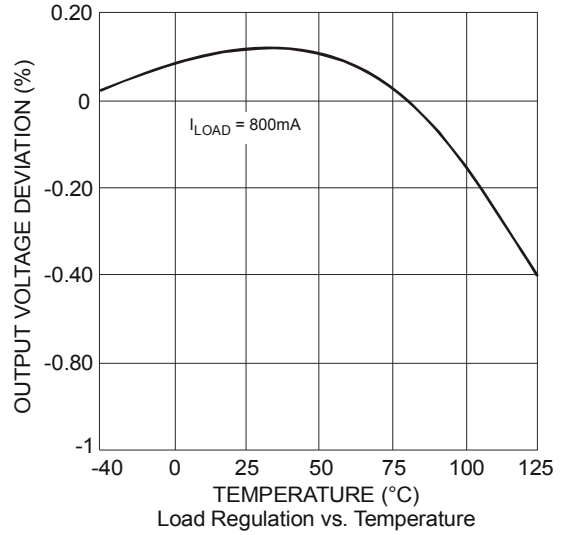
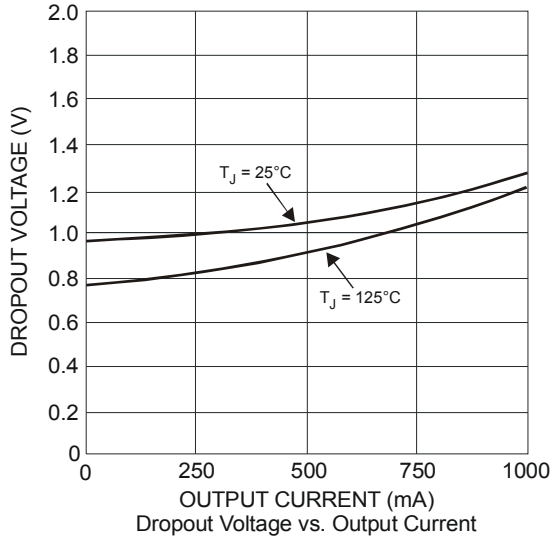

Ordering Information

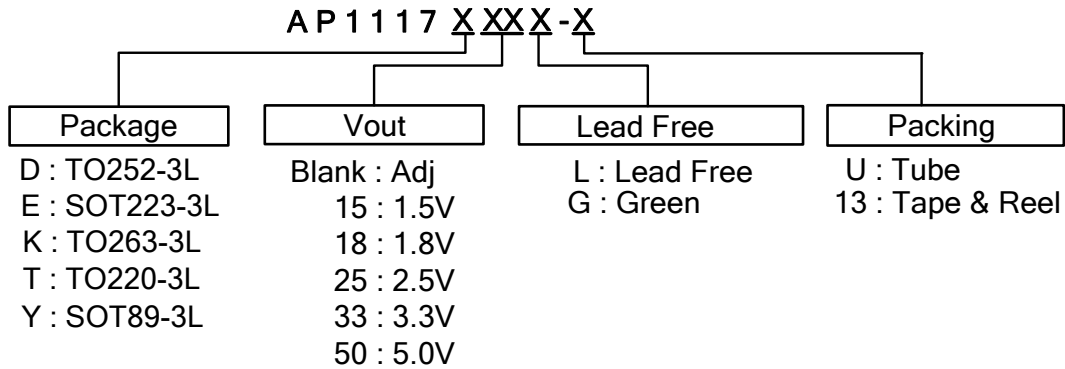

| Device | Package Code | Packaging (Note 8) | Tube | | 13" Tape and Reel | |
|---------------|--------------|--------------------|----------|--------------------|-------------------|--------------------|
| | | | Quantity | Part Number Suffix | Quantity | Part Number Suffix |
| AP1117DXXL-13 | D | TO252-3L | NA | NA | 2500/Tape & Reel | -13 |
| AP1117DXXG-13 | D | TO252-3L | NA | NA | 2500/Tape & Reel | -13 |
| AP1117EXXL-13 | E | SOT223-3L | NA | NA | 2500/Tape & Reel | -13 |
| AP1117EXXG-13 | E | SOT223-3L | NA | NA | 2500/Tape & Reel | -13 |
| AP1117KXXL-13 | K | TO263-3L | NA | NA | 800/Tape & Reel | -13 |
| AP1117KXXG-13 | K | TO263-3L | NA | NA | 800/Tape & Reel | -13 |
| AP1117TXXL-U | T | TO220-3L | 50 | -U | NA | NA |
| AP1117TXXG-U | T | TO220-3L | 50 | -U | NA | NA |
| AP1117YXXL-13 | Y | SOT89-3L | NA | NA | 2500/Tape & Reel | -13 |
| AP1117YXXG-13 | Y | SOT89-3L | NA | NA | 2500/Tape & Reel | -13 |

Notes: 8. Pad layout as shown on Diodes Inc. suggested pad layout document AP02001, which can be found on our website at <http://www.diodes.com/datasheets/ap02001.pdf>.

Marking Information

(1) SOT223-3L

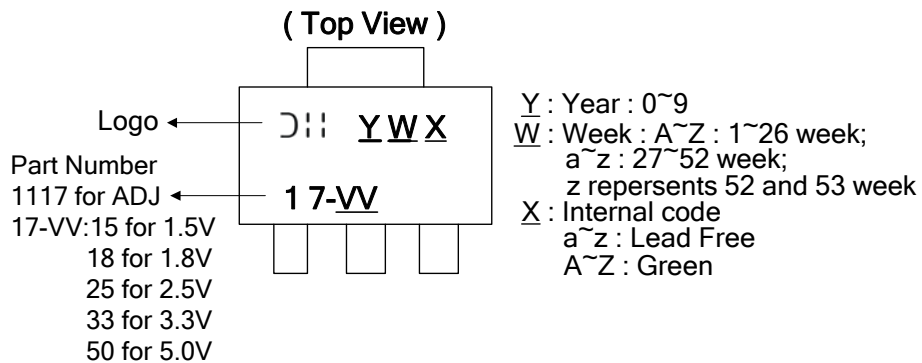

Marking Information (cont.)

(2) TO252-3L

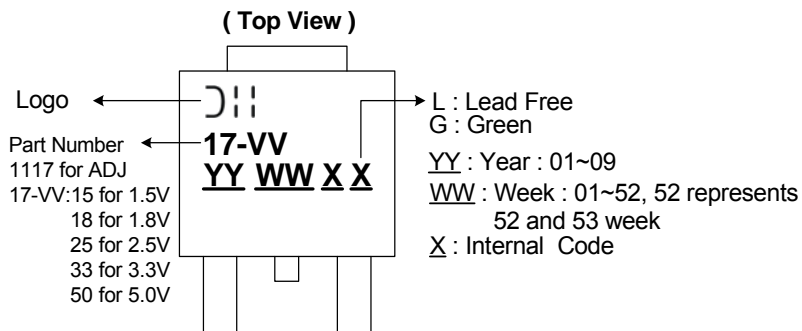

(3) SOT89-3L

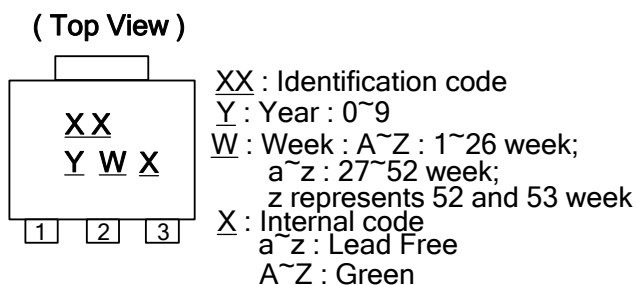

Marking Code Table

| Identification Code | Output Version |
|---------------------|----------------|
| DA | AP1117-ADJ |
| DB | AP1117-1.5V |
| DC | AP1117-1.8V |
| DD | AP1117-2.5V |
| DE | AP1117-3.3V |
| DF | AP1117-5.0V |

(4) TO263-3L

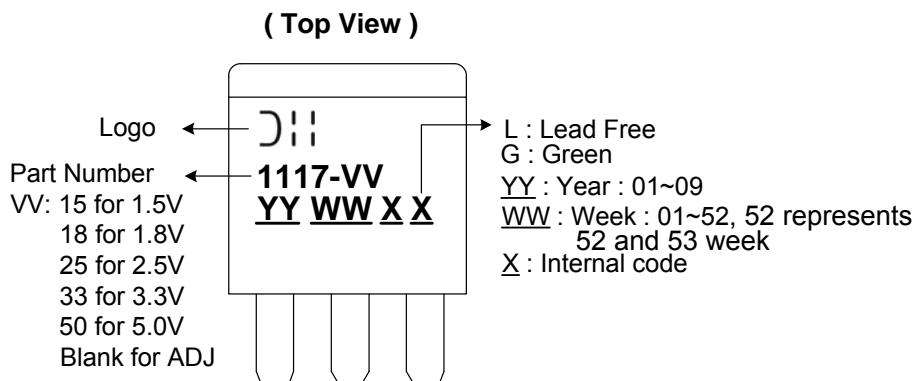

Marking Information (cont.)

(5) TO220-3L

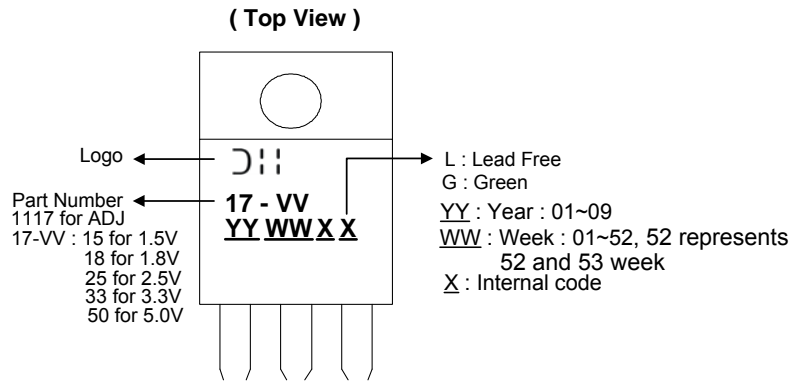

Package Outline Dimensions (All Dimensions in mm)

(1) Package Type: SOT223-3L

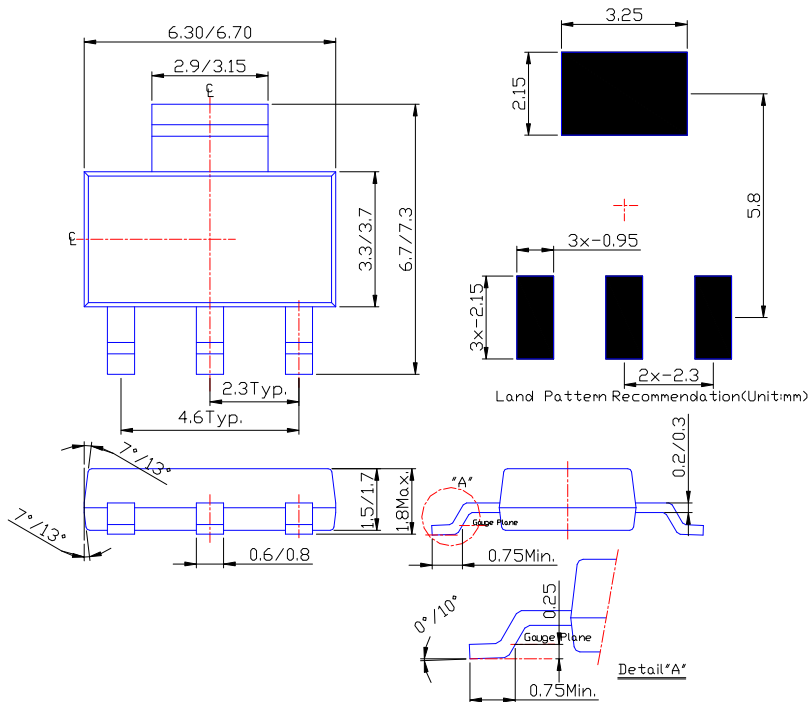

Package Outline Dimensions (All Dimensions in mm) (cont.)

(2) Package Type: TO252-3L

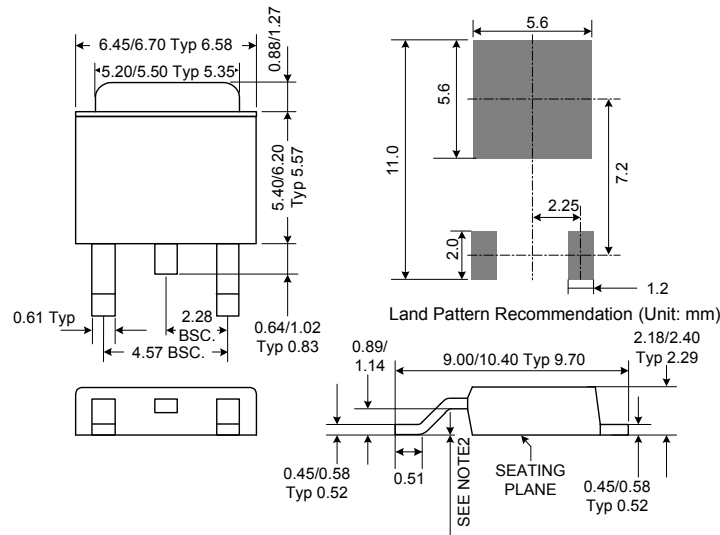

(3) Package Type: SOT89-3L

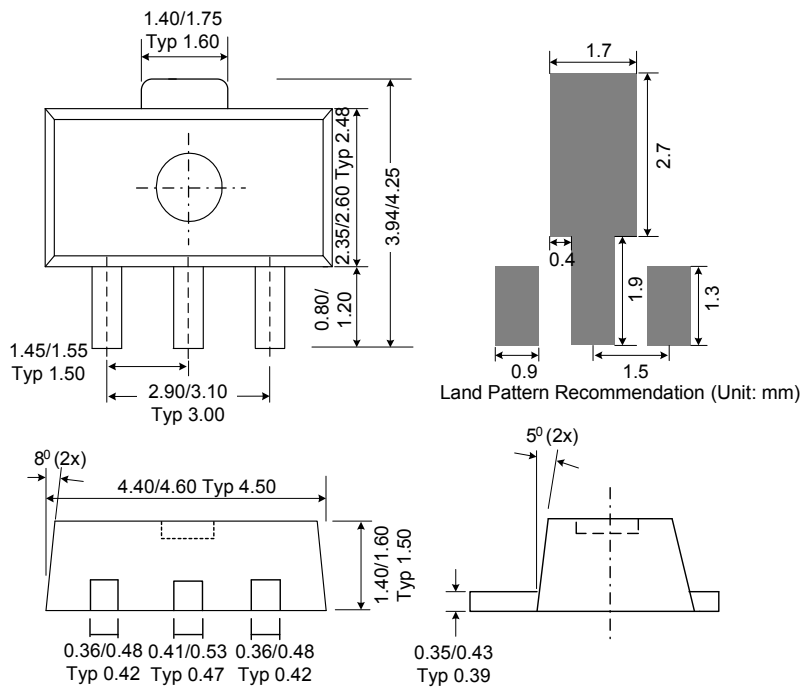

Package Outline Dimensions (All Dimensions in mm) (cont.)

(4) Package Type: TO263-3L

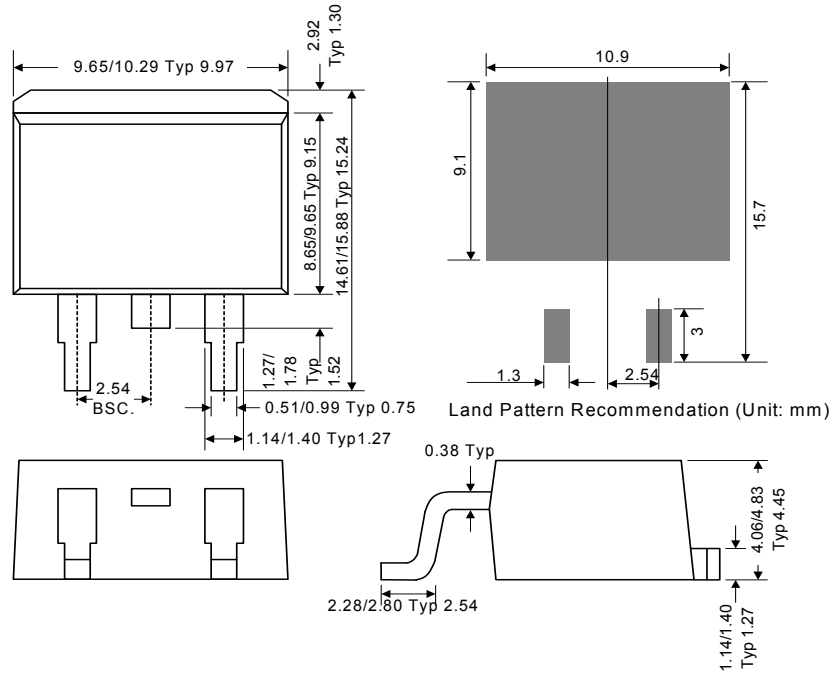

(5) Package Type: TO220-3L

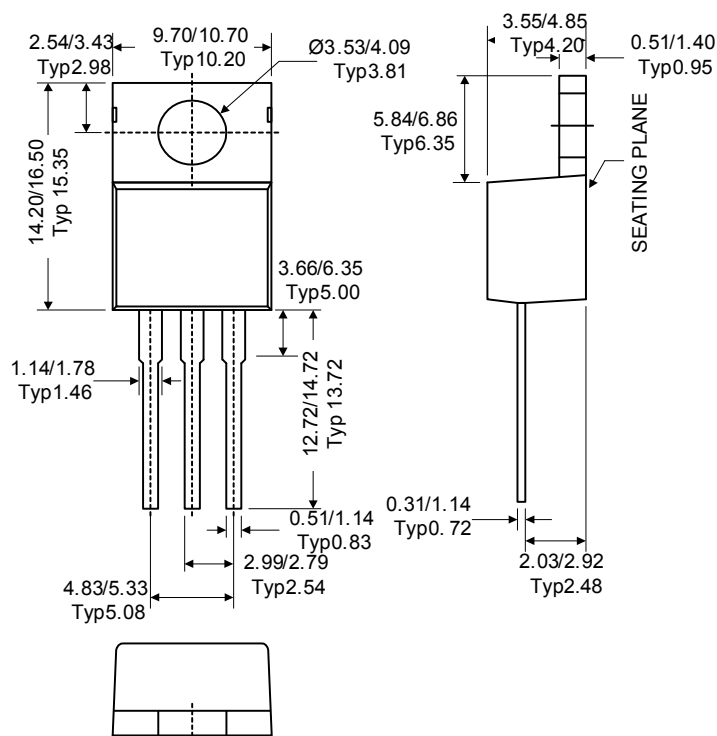

IMPORTANT NOTICE

DIODES INCORPORATED MAKES NO WARRANTY OF ANY KIND, EXPRESS OR IMPLIED, WITH REGARDS TO THIS DOCUMENT, INCLUDING, BUT NOT LIMITED TO, THE IMPLIED WARRANTIES OF MERCHANTABILITY AND FITNESS FOR A PARTICULAR PURPOSE (AND THEIR EQUIVALENTS UNDER THE LAWS OF ANY JURISDICTION).

Diodes Incorporated and its subsidiaries reserve the right to make modifications, enhancements, improvements, corrections or other changes without further notice to this document and any product described herein. Diodes Incorporated does not assume any liability arising out of the application or use of this document or any product described herein; neither does Diodes Incorporated convey any license under its patent or trademark rights, nor the rights of others. Any Customer or user of this document or products described herein in such applications shall assume all risks of such use and will agree to hold Diodes Incorporated and all the companies whose products are represented on Diodes Incorporated website, harmless against all damages.

Diodes Incorporated does not warrant or accept any liability whatsoever in respect of any products purchased through unauthorized sales channel.

Should Customers purchase or use Diodes Incorporated products for any unintended or unauthorized application, Customers shall indemnify and hold Diodes Incorporated and its representatives harmless against all claims, damages, expenses, and attorney fees arising out of, directly or indirectly, any claim of personal injury or death associated with such unintended or unauthorized application.

Products described herein may be covered by one or more United States, international or foreign patents pending. Product names and markings noted herein may also be covered by one or more United States, international or foreign trademarks.

LIFE SUPPORT

Diodes Incorporated products are specifically not authorized for use as critical components in life support devices or systems without the express written approval of the Chief Executive Officer of Diodes Incorporated. As used herein:

A. Life support devices or systems are devices or systems which:

1. are intended to implant into the body, or
2. support or sustain life and whose failure to perform when properly used in accordance with instructions for use provided in the labeling can be reasonably expected to result in significant injury to the user.

B. A critical component is any component in a life support device or system whose failure to perform can be reasonably expected to cause the failure of the life support device or to affect its safety or effectiveness.

Customers represent that they have all necessary expertise in the safety and regulatory ramifications of their life support devices or systems, and acknowledge and agree that they are solely responsible for all legal, regulatory and safety-related requirements concerning their products and any use of Diodes Incorporated products in such safety-critical, life support devices or systems, notwithstanding any devices- or systems-related information or support that may be provided by Diodes Incorporated. Further, Customers must fully indemnify Diodes Incorporated and its representatives against any damages arising out of the use of Diodes Incorporated products in such safety-critical, life support devices or systems.

Copyright © 2011, Diodes Incorporated

www.diodes.com