



General Description

The AP3609 is an eight-channel constant current sink with current match used for LED driver. It uses an external resistor to set the current for eight LED strings with an accuracy of $\pm 1.5\%$. The full scale LED current can be adjusted from 10mA to 100mA for each channel. The LED light can be adjusted by PWM dimming function.

The device can keep working when LED opens without damage. It features under voltage lockout protection and over temperature protection.

The AP3609 has two interface terminals (FB and FBX). They enable the device to be connected in parallel.

The AP3609 is available in SOIC-16 package.

Features

- Input Voltage Range: 4.2V to 5.5V
- Typical Output Current: 480mA (60mA/1V per Channel)
- Maximum Output Current: 800mA (100mA/1.5V per Channel)
- Current Match Accuracy: $\pm 1.5\%$
- PWM Dimming Control
- Open LED Self-check and Protection
- Under Voltage Lockout Protection
- Over Temperature Protection
- Enable Parallel Application

Applications

- Notebook
- LCD Display Modules
- LCD Monitor
- LCD TV

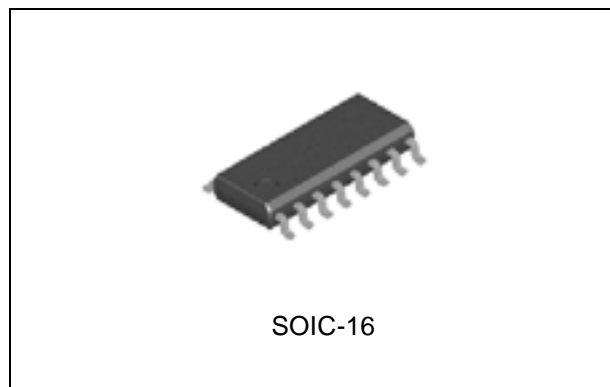

Figure 1. Package Type of AP3609

Pin Configuration

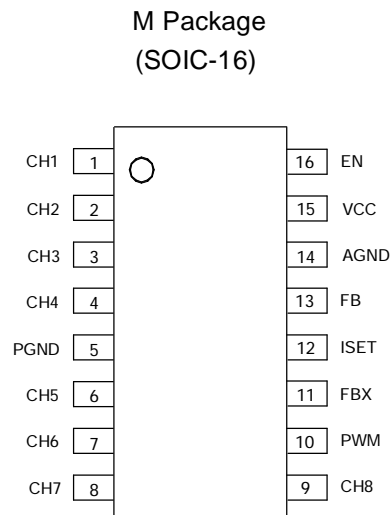
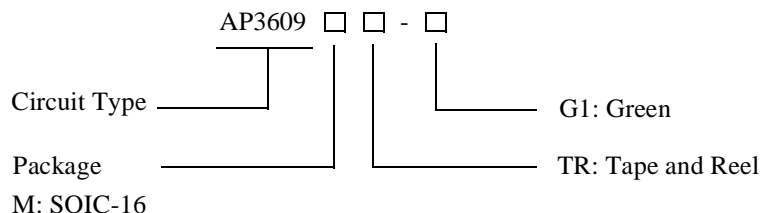

Figure 2. Pin Configuration of AP3609 (Top View)

Pin Description

Pin Number	Pin Name	Function
1, 2, 3, 4, 6, 7, 8, 9	CH1 to CH8	White LED cathode connection pin. These pins should be connected to GND if not used
5	PGND	Ground pin. It would be useful when connected with PGND and exposed pad
10	PWM	PWM dimming control pin. Adding a PWM signal to this pin to control LED dimming (see Figure 10 for detail dimming control mode). If not used, connect it to the high level
11	FBX	This pin is an interface terminal. Connecting it with FB pin can achieve parallel application. If not used, leave it unconnected
12	ISET	LED current set pin. An external resistor is connected to this pin to set the current of each channel according to $I_{\text{CHANNEL}} = 1.194 * 400 / R_{\text{ISET}}$
13	FB	Feedback pin. This pin is an interface terminal, which samples the voltage of each channel, and outputs the lowest voltage of the string to DC/DC converter
14	AGND	Ground pin. It would be useful when connected with PGND and exposed pad
15	VCC	Input voltage pin
16	EN	Enable pin. Logic high enables the IC and logic low disables the IC

**EIGHT-CHANNEL CONSTANT CURRENT SINK WITH CURRENT MATCH AP3609****Ordering Information**

Package	Temperature Range	Part Number	Marking ID	Packing Type
SOIC-16	-40 to 85°C	AP3609MTR-G1	AP3609M-G1	Tape & Reel

BCD Semiconductor's Pb-free products, as designated with "G1" suffix in the part number, are RoHS compliant and green.

Absolute Maximum Ratings (Note 1)

Parameter	Symbol	Value	Unit
Input Voltage	V_{CC}	-0.3 to 6	V
ISET Pin Voltage	V_{ISET}	-0.3 to 6	V
EN Pin Voltage	V_{EN}	-0.3 to 6	V
Feedback Pin Voltage	V_{FB}	-0.3 to 6	V
PWM Pin Voltage	V_{PWM}	-0.3 to 6	V
Voltage per Channel (Note 2)	V_{CHX}	-0.3 to 40	V
Thermal Resistance (Junction to Ambient, no Heat Sink)	θ_{JA}	80	°C/W
Operating Junction Temperature	T_J	150	°C
Storage Temperature Range	T_{STG}	-65 to 150	°C
Lead Temperature (Soldering, 10sec)	T_{LEAD}	260	°C
ESD (Machine Model)		200	V
ESD (Human Body Model)		6000	V

Note 1: Stresses greater than those listed under "Absolute Maximum Ratings" may cause permanent damage to the device. These are stress ratings only, and functional operation of the device at these or any other conditions beyond those indicated under "Recommended Operating Conditions" is not implied. Exposure to "Absolute Maximum Ratings" for extended periods may affect device reliability.

Note 2: Breakdown voltage.



EIGHT-CHANNEL CONSTANT CURRENT SINK WITH CURRENT MATCH AP3609

Recommended Operating Conditions

Parameter	Symbol	Min	Max	Unit	
Input Voltage	V_{CC}	4.2	5.5	V	
Recommended PWM Dimming Frequency	f_{PWM}	0.1	25	kHz	
Full Scale Setting Current per Channel	$V_{CHX} \geq 0.5V$	I_{CHX}	10	25	mA
	$V_{CHX} \geq 1V$		10	65	
	$V_{CHX} \geq 1.5V$		10	110	
Operating Temperature Range	T_A	-40	85	$^{\circ}C$	

Electrical Characteristics

Limits in standard typeface are guaranteed for $V_{IN}=V_{EN}=5V$, $R_{ISET}=8k\Omega$, $T_A=25^{\circ}C$, unless otherwise specified.

Parameter	Symbol	Conditions	Min	Typ	Max	Unit
Input Section						
Input Voltage	V_{IN}		4.2		5.5	V
Quiescent Current	I_Q	No load		0.5	1	mA
Shutdown Quiescent Current	I_{SDB}	$V_{EN}=0V$		0.1	1	μA
Under Voltage Lockout Threshold	V_{UVLO}	Falling Edge	3.6	3.8	4.0	V
Under Voltage Lockout Hysteresis	V_{HUVLO}			200		mV
Current Sink Section						
ISET Reference Voltage	V_{ISET}		1.170	1.194	1.218	V
Current Multiplication Ratio	K	I_{CHX}/I_{SET}	370	400	430	
Maximum Output Current per Channel	I_{CHX_MAX}	$V_{CHX}=0.5V$	23	45		mA
		$V_{CHX}=1V$	65	70		
		$V_{CHX}=1.5V$	110	120		
Current Matching between Any Two Channels	I_{CH_MATCH}	$I_{CHX}=60mA$ $V_{CHX}=1V$	-1.5		1.5	%
Current Sink Saturation Voltage per Channel	V_{CHX_SAT}	$I_{CHX}=20mA$			0.45	V
		$I_{CHX}=60mA$			0.8	
		$I_{CHX}=100mA$			1.2	
Output Current Line Regulation		$V_{CC}=4.2V$ to $5.5V$			2	%/V
Output Current Load Regulation		$V_{CHX}=0.5V$ to $2.8V$			4	%



EIGHT-CHANNEL CONSTANT CURRENT SINK WITH CURRENT MATCH AP3609

Electrical Characteristics (Continued)

Limits in standard typeface are guaranteed for $V_{IN}=V_{EN}=5V$, $R_{ISET}=8k\Omega$, $T_A=25^\circ C$, unless otherwise specified.

Parameter	Symbol	Conditions	Min	Typ	Max	Unit
Enable Section						
EN Pin High Level Threshold Voltage	V_{IH_EN}		1.8			V
EN Pin Low Level Threshold Voltage	V_{IL_EN}				0.8	V
PWM Dimming Section						
PWM High Level Threshold Voltage	V_{IH_PWM}		1.8			V
PWM Low Level Threshold Voltage	V_{IL_PWM}				0.8	V
Interface Section						
Feedback Output Current	I_{FB}		5	15		μA
Total Device						
Self-check Voltage @ Open LED	V_{CHECK}			3.0		V
Thermal Shutdown Temperature	T_{OTSD}			160		$^\circ C$
Thermal Shutdown Hysteresis	T_{HYS}			20		$^\circ C$

Typical Performance Characteristics

$V_{IN}=V_{EN}=5V$, $R_{ISET}=8k\Omega$, $T_A=25^\circ C$, unless otherwise specified.

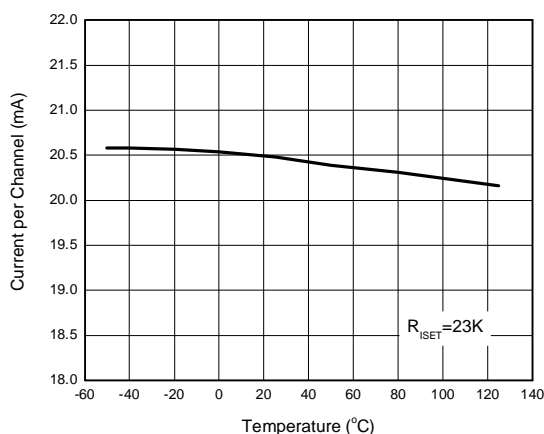

Figure 4. Current per Channel vs. Temperature

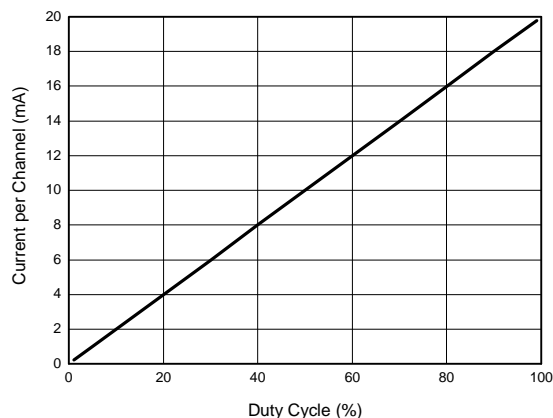

Figure 5. Current per Channel vs. Duty Cycle



EIGHT-CHANNEL CONSTANT CURRENT SINK WITH CURRENT MATCH AP3609

Typical Performance Characteristics (Continued)

$V_{IN}=V_{EN}=5V$, $R_{ISET}=8k\Omega$, $T_A=25^\circ C$, unless otherwise specified.

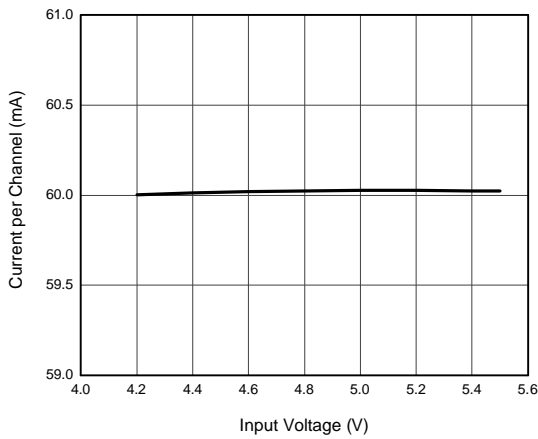

Figure 6. Current per Channel vs. Input Voltage

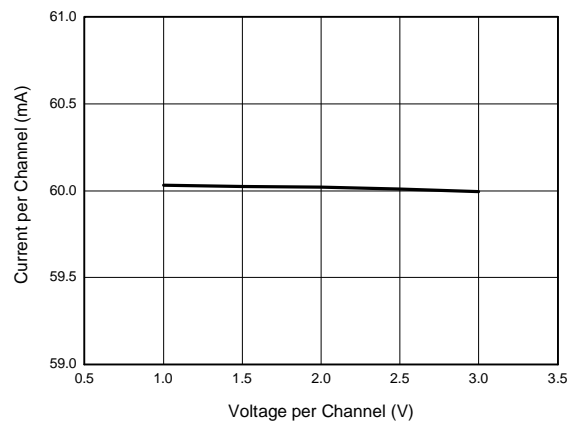

Figure 7. Current per Channel vs. Voltage per Channel

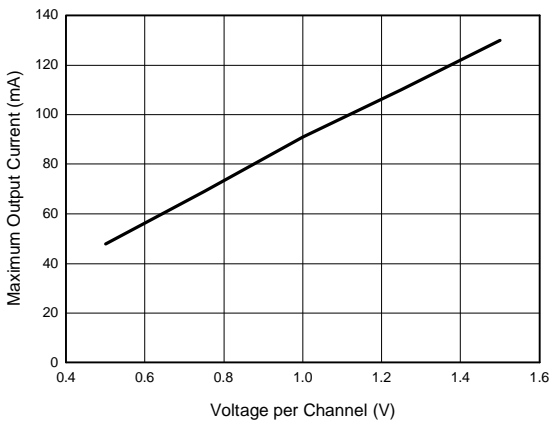

Figure 8. Maximum Output Current vs. Voltage per Channel

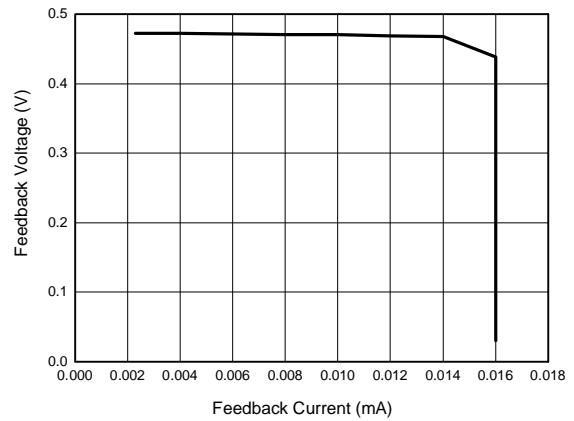

Figure 9. Feedback Voltage vs. Feedback Current

Function Description

The AP3609 is designed for LED display application which contains eight well-matched current sinks to provide constant current through LED. The full scale LED current can be adjusted from 10mA to 100mA per channel with an external resistor. If there is some channel unused, the channel pin should be connected to ground. The LED bright dimming can be achieved through PWM dimming.

The AP3609 can work with a DC/DC converter to drive LED arrays for good performance. The device can keep working when LED opens without damage, and it features under voltage lockout protection and over temperature protection. The detailed information will be discussed in open LED self-check and protection section.

1. LED Current Setting

The maximum LED current can be set up to 100mA per channel by ISET pin. When the LED current is greater than 100mA, two or more channels can be paralleled to achieve larger drive current. To set the reference current I_{SET} , connect a resistor R_{ISET} between this pin and ground. The value of R_{ISET} can be calculated by the following formula:

$$I_{SET} = 1.194V / R_{ISET}$$

This reference current is multiplied internally with a gain (K) of 400, and then mirrored on all enabled channels. This sets the maximum LED current, referred to as 100% current (I_{CHX_MAX}). The value can be calculated by the following formula:

$$I_{CHX_MAX} = K \cdot I_{SET}$$

The LED current can be reduced from 100% by PWM dimming control.

2. PWM Dimming Mode

The LED current can be adjusted by applying the PWM signal to PWM pin. On this mode, all enabled channels are adjusted at the same time and the brightness can be adjusted from 1%* I_{CHX_MAX} to 100%* I_{CHX_MAX} (@ $f_{Dimming}=2kHz$). During the "high level" time of the PWM signal, the LED turns on and the 100% current flows through LED. During the "low level" time of the PWM signal, the LED turns off and almost no current flows through LED. So the average current through LED is changed and the brightness is adjusted. The external PWM signal frequency applied to PWM pin can be allowed to 100Hz or higher.

An example for PWM dimming is shown in Figure 10. All 8 channels are set to the maximum current I_{CHX_MAX} at the beginning. When a 50% duty cycle PWM signal is applied to PWM pin, average current valued 50%* I_{CHX_MAX} flows through the 8 channels. When an 80% duty cycle PWM signal is applied to PWM pin, average current valued 80%* I_{CHX_MAX} flows through the 8 channels.

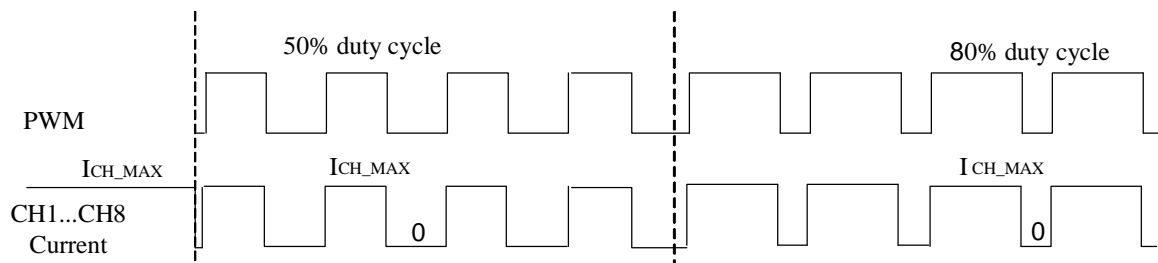

Figure 10. PWM Dimming Example of AP3609



Function Description (Continued)

3. Open LED Self-Check and Protection

The AP3609 can work with a DC/DC converter to achieve good performance, such as self-check and protection against open LED. The FB pin samples voltage of each channel, and outputs the lowest voltage to DC/DC converter. When AP3609 gets shutdown signal from EN pin or PWM voltage is low, AP3609 outputs a high Z signal (floating). The FB voltage should be decided by external pull-up resistor connected to it. Then the DC/DC converter can be controlled by AP3609.

If any enabled LED string opens, voltage on the corresponding CHX pin goes to zero and the FB pin outputs the zero voltage to boost converter. So the boost converter operates in open loop and the voltage on remaining CHX pin goes higher. Once the voltage

on remaining CHX pin reaches the self-check voltage 3V, the AP3609 begins looking up the open string. After finding the open channel, AP3609 removes the corresponding CHX pin from boost control loop, then the boost circuit is controlled in the normal manner. Once the circuit returns normal operation, the voltage on the CHX pin is regulated to the normal level. It is necessary to pay attention that the open strings are removed from boost regulation, but not disabled. If the open LED string is reconnected, it will sink current up to the programmed current level.

4. Parallel Operation Mode

The AP3609 can be paralleled to drive more strings of LED. Connecting an AP3609 FB pin with another AP3609 FBX pin can achieve parallel application. More details please refer to Figure 11.

EIGHT-CHANNEL CONSTANT CURRENT SINK WITH CURRENT MATCH AP3609

Typical Application

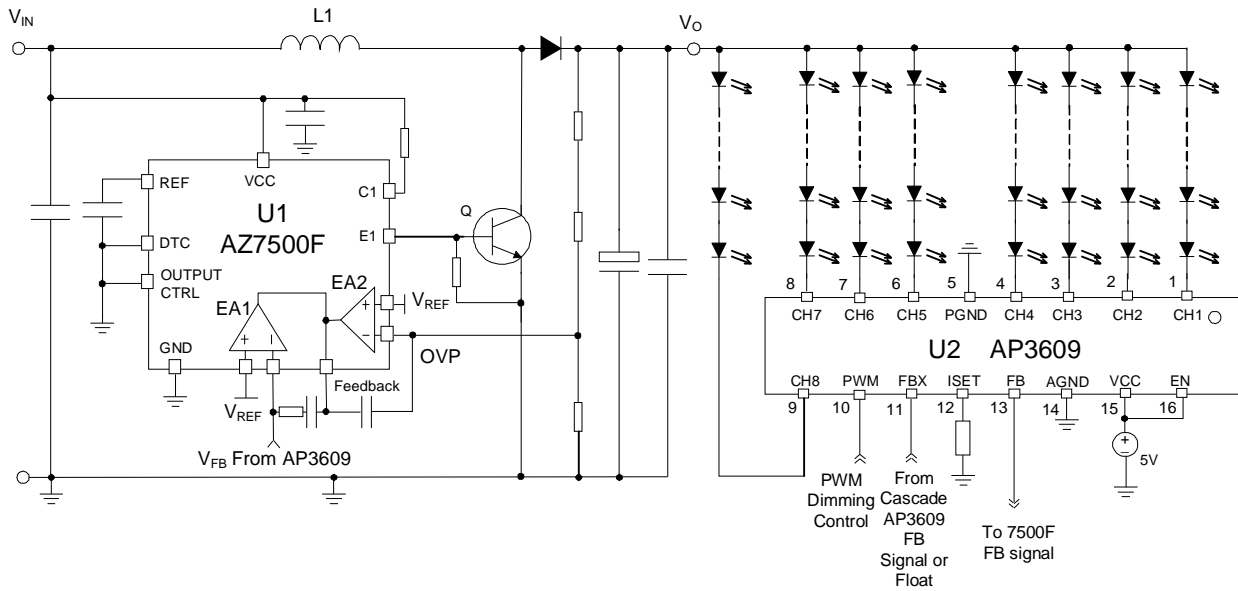

Single Channel

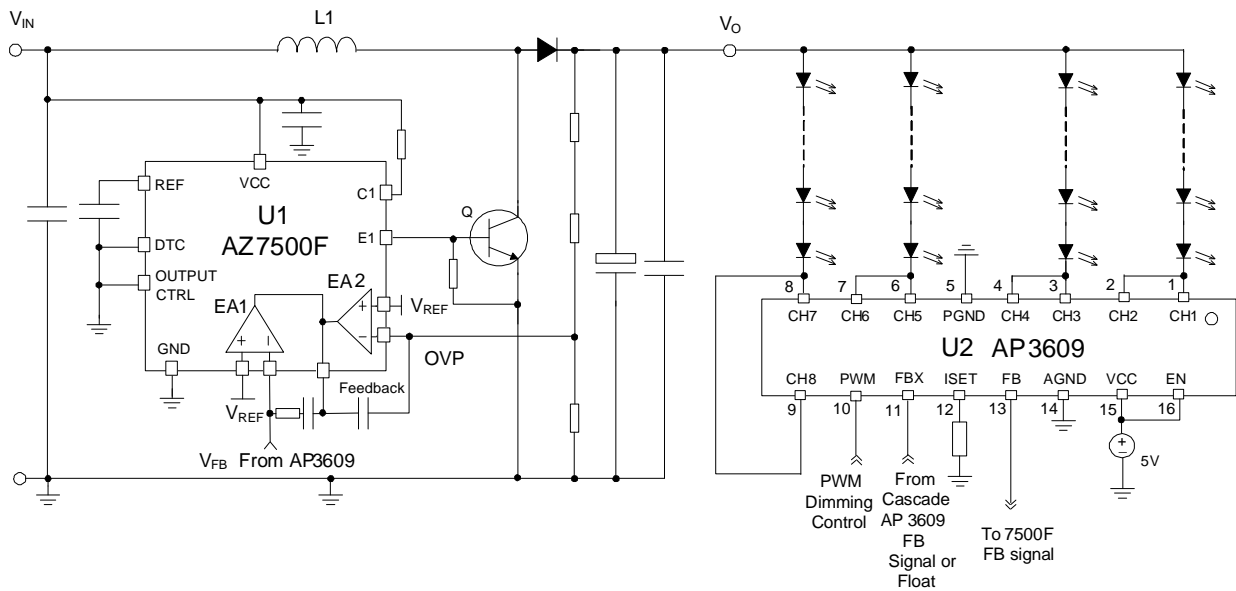

Paralleled Channels

Figure 11. Typical Applications of AP3609



EIGHT-CHANNEL CONSTANT CURRENT SINK WITH CURRENT MATCH AP3609

Mechanical Dimensions

SOIC-16

Unit: mm(inch)

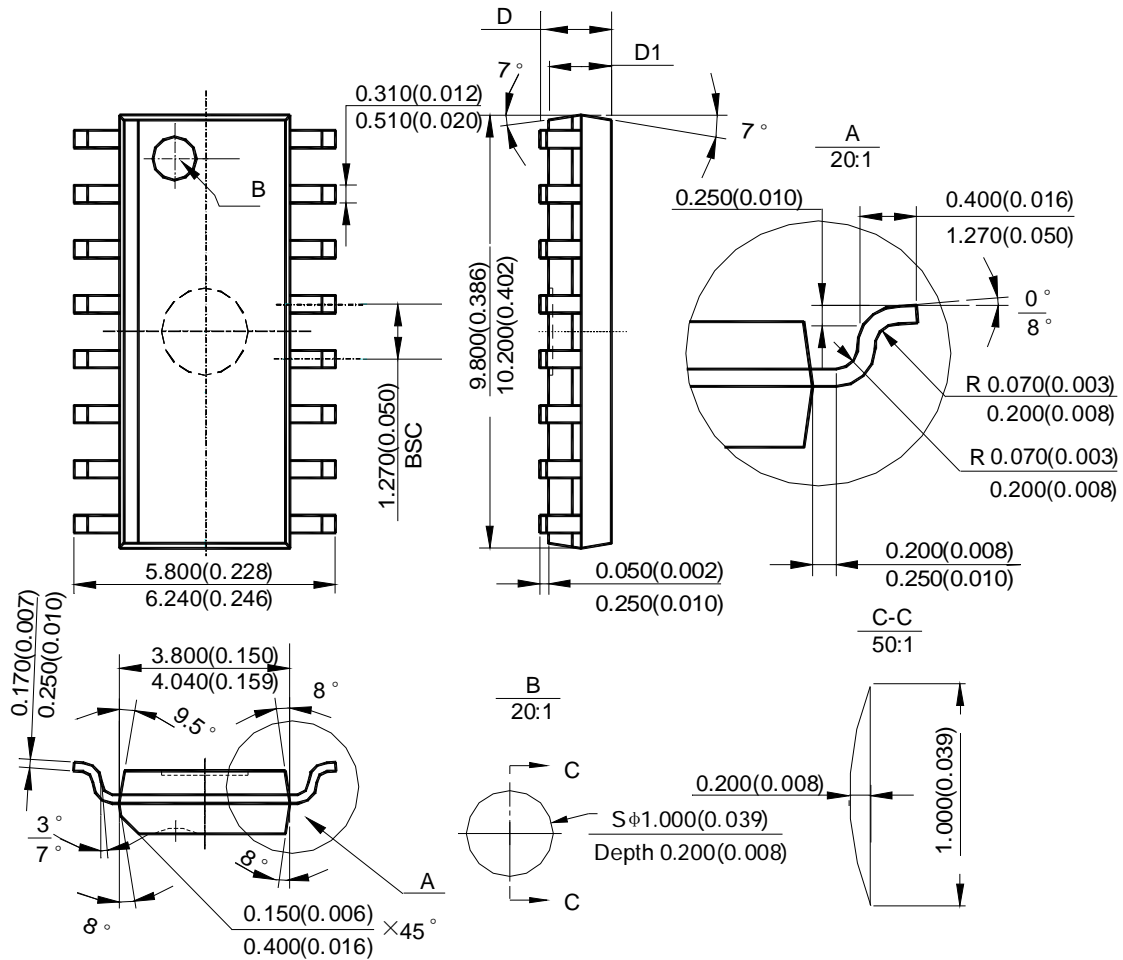

Note: Eject hole, oriented hole and mold mark is optional.

Symbol	D				D1			
	min(mm)	max(mm)	min(inch)	max(inch)	min(mm)	max(mm)	min(inch)	max(inch)
Option1	1.350	1.750	0.053	0.069	1.250	1.650	0.049	0.065
Option2	-	1.260	-	0.050	1.020	-	0.040	-



EIGHT-CHANNEL CONSTANT CURRENT SINK WITH CURRENT MATCH AP3609

Mounting Pad Layout

SOIC-16

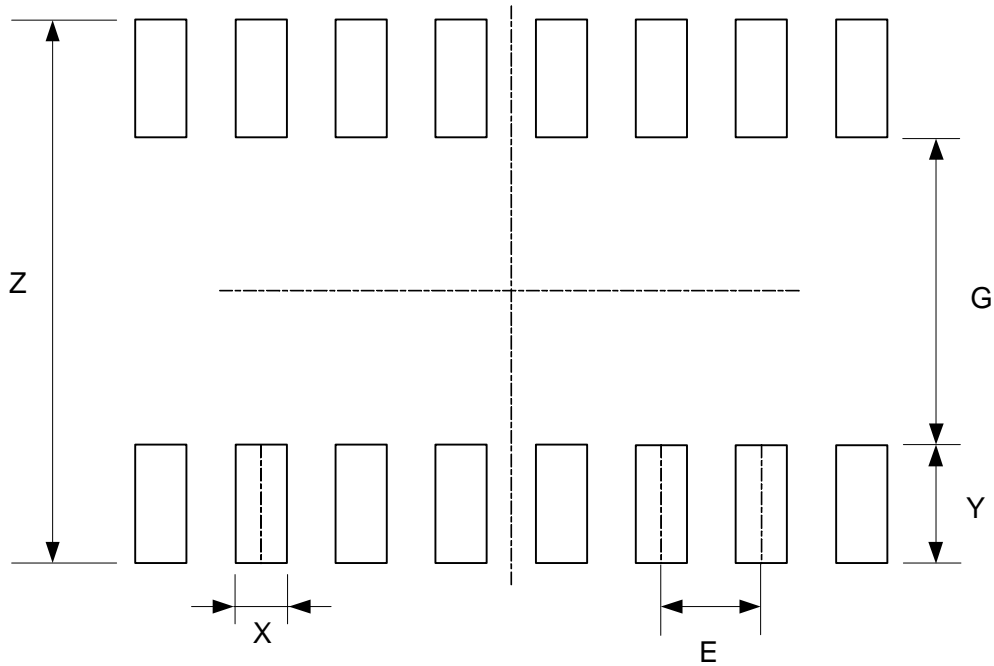

Dimensions	Z (mm)/(inch)	G (mm)/(inch)	X (mm)/(inch)	Y (mm)/(inch)	E (mm)/(inch)
Value	6.900/0.272	3.900/0.154	0.650/0.026	1.500/0.059	1.270/0.050



BCD Semiconductor Manufacturing Limited

<http://www.bcdsemi.com>

IMPORTANT NOTICE

BCD Semiconductor Manufacturing Limited reserves the right to make changes without further notice to any products or specifications herein. BCD Semiconductor Manufacturing Limited does not assume any responsibility for use of any its products for any particular purpose, nor does BCD Semiconductor Manufacturing Limited assume any liability arising out of the application or use of any its products or circuits. BCD Semiconductor Manufacturing Limited does not convey any license under its patent rights or other rights nor the rights of others.

MAIN SITE

- Headquarters

BCD (Shanghai) Micro-electronics Limited

No. 1600, Zi Xing Road, Shanghai ZiZhu Science-based Industrial Park, 200241, P. R. C.
Tel: +86-021-2416-2266, Fax: +86-021-2416-2277

- Wafer Fab

Shanghai SIM-BCD Semiconductor Manufacturing Co., Ltd.

800 Yishan Road, Shanghai 200233, China
Tel: +021-6485-1491, Fax: +86-021-5450-0008

REGIONAL SALES OFFICE

Shenzhen Office

Shanghai SIM-BCD Semiconductor Manufacturing Co., Ltd., Shenzhen Office

Unit A Room 1203, Skyworth Bldg., Gaoxin Ave.1.S., Nanshan District
Shenzhen 518057, China

Tel: +86-0755-8660-4900, Fax: +86-0755-8660-4958

Taiwan Office (Taipei)

BCD Semiconductor (Taiwan) Company Limited

3F, No.17, Lane 171, Sec. 2, Jiu-Zong Rd., Nei-Hu Dist., Taipei(114), Taiwan, R.O.C
Tel: +886-2-2656-2808

Fax: +886-2-2656-2806/26562950

Taiwan Office (Hsinchu)

BCD Semiconductor (Taiwan) Company Limited

8F, No.176, Sec. 2, Gong-Dao 5th Road, East District
HsinChu City 300, Taiwan, R.O.C

Tel: +886-3-5160181, Fax: +886-3-5160181

USA Office

BCD Semiconductor Corp.

48460 Kato Road, Fremont, CA 94538, USA
Tel: +1-510-668-1950

Fax: +1-510-668-1990

Korea Office

BCD Semiconductor Limited Korea office.

Room 101-1112, Digital-Empire II, 486 Sin-dong,
Yeongtong-Gu, Suwon-city, Gyeonggi-do, Korea

Tel: +82-31-695-8430