

**LOW-POWER OFF-LINE PRIMARY SIDE REGULATION CONTROLLER AP3768****General Description**

The AP3768 is a high performance AC/DC power supply controller for battery charger and adapter applications. The device uses Pulse Frequency Modulation (PFM) method to build discontinuous conduction mode (DCM) flyback power supplies.

The AP3768 provides accurate constant voltage, constant current (CV/CC) regulation without requiring an opto-coupler and secondary control circuitry. It also eliminates the need of loop compensation circuitry while maintaining stability. The AP3768 achieves excellent regulation and high average efficiency, yet meets the requirement for no-load consumption less than 30mW.

The AP3768 has the built-in programmable cable voltage drop compensation function, which make it flexible to accommodate various cables with different gauges and lengths.

The AP3768 is available in SOIC-8 package.

Features

- Primary Side Control for Eliminating Opto-coupler and Secondary CV/CC Control Circuitry
- 30mW No-load Input Power
- Programmable Output Cable Voltage Drop Compensation
- Proprietary CC Tightening Technique to Achieve Vertical CC Profile
- Compensation for External Component Temperature Variations
- Flyback Topology in DCM Operation
- Random Frequency Adjustment to Reduce System EMI
- Built-in Soft Start
- Over Voltage Protection
- Short Circuit Protection
- SOIC-8 Package

Applications

- Adapter/Chargers for Cell/Cordless Phones, PDAs, MP3 and Other Portable Apparatus
- LED Driver
- Standby and Auxiliary Power Supplies



Figure 1. Package Type of AP3768

LOW-POWER OFF-LINE PRIMARY SIDE REGULATION CONTROLLER AP3768
Pin Configuration

Figure 2. Pin Configuration of AP3768 (Top View)

Pin Description

Pin Number	Pin Name	Function
1	CS	The primary current sense
2	VCC	Supply voltage
3	OUT	This pin drives the base of external power NPN switch
4	GND	Ground
5	CPC	This pin connects a capacitor for output cable compensation
6	FB	The voltage feedback from the auxiliary winding
7	CPR	Connects a resistor to FB pin for adjustable output cable compensation
8	BIAS	This pin sets the bias current inside AP3768 with an external resistor to GND

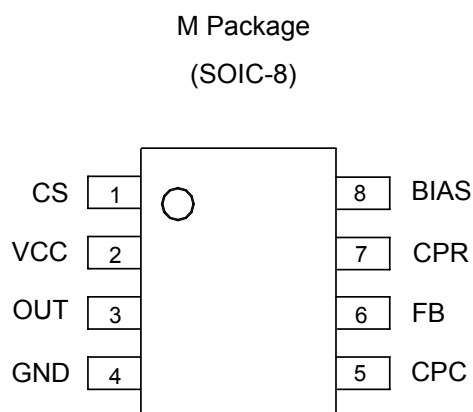

LOW-POWER OFF-LINE PRIMARY SIDE REGULATION CONTROLLER AP3768

Functional Block Diagram

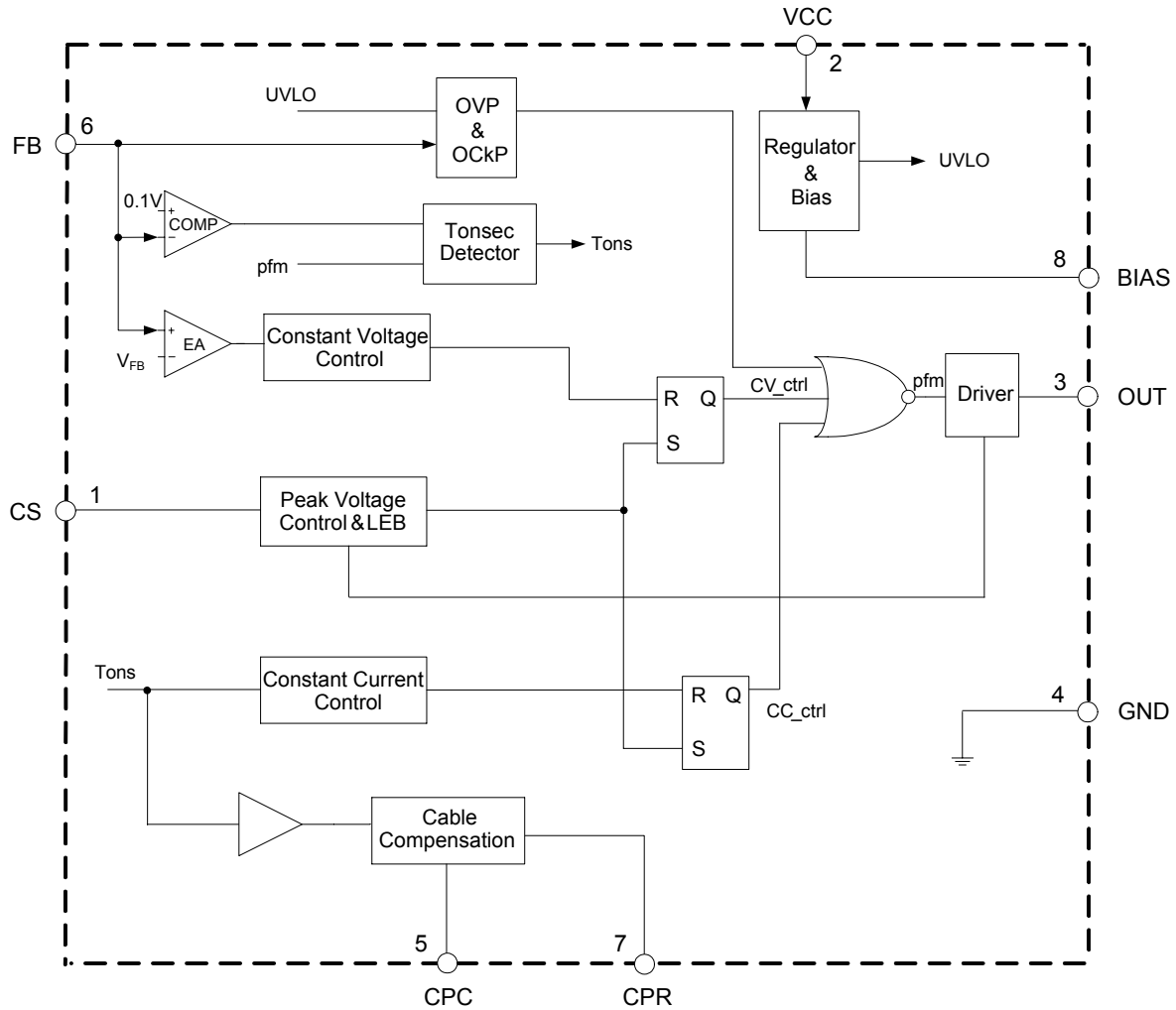
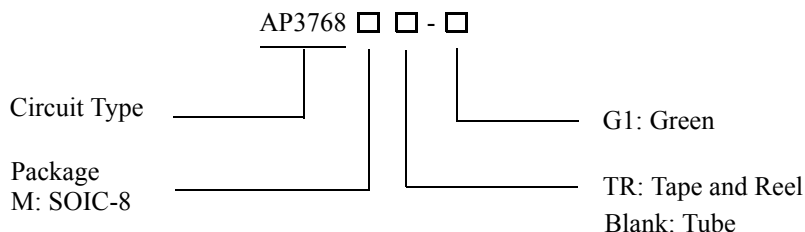

Figure 3. Functional Block Diagram of AP3768

**LOW-POWER OFF-LINE PRIMARY SIDE REGULATION CONTROLLER AP3768****Ordering Information**

Package	Temperature Range	Part Number	Marking ID	Packing Type
SOIC-8	-40 to 85°C	AP3768M-G1	3768M-G1	Tube
		AP3768MTR-G1	3768M-G1	Tape & Reel

BCD Semiconductor's products, as designated with "G1" suffix in the part number, are RoHS compliant and Green.

Absolute Maximum Ratings (Note 1)

Parameter	Value	Unit
Voltage at VCC Pin to GND	-0.3 to 36	V
Voltage at CS, OUT to GND	-0.3 to 7	V
FB input	-40 to 10	V
Output Current at OUT	Internally limited	A
Operating Junction Temperature	150	°C
Storage Temperature	-65 to 150	°C
Lead Temperature (Soldering, 10s)	300	°C
Thermal Resistance Junction-to-Ambient	190	°C/W
ESD (Machine Model)	200	V
ESD (Human Body Model)	2000	V

Note 1: Stresses greater than those listed under "Absolute Maximum Ratings" may cause permanent damage to the device. These are stress ratings only, and functional operation of the device at these or any other conditions beyond those indicated under "Recommended Operating Conditions" is not implied. Exposure to "Absolute Maximum Ratings" for extended periods may affect device reliability.



LOW-POWER OFF-LINE PRIMARY SIDE REGULATION CONTROLLER AP3768

Electrical Characteristics

($V_{CC}=15V$, $T_A=25^{\circ}C$, unless otherwise specified.)

Parameter	Symbol	Conditions	Min	Typ	Max	Unit	
UVLO SECTION							
Start-up Threshold	$V_{TH(ST)}$		17	18.5	21	V	
Minimal Operating Voltage	$V_{OPR(min)}$		8.2	9.2	10.2	V	
Reference Voltage							
BIAS Pin Voltage	V_{BIAS}	$R_{BIAS}=200k\Omega$ After Turn On	1.0	1.1	1.2	V	
STANDBY CURRENT SECTION							
Start-up Current	I_{ST}	$V_{CC}=V_{TH(ST)}-0.5V$, $R_{BIAS}=200k\Omega$ Before start-up			0.6	μA	
Operating Current	$I_{CC(OPR)}$	$R_{BIAS}=200k\Omega$		390	480	μA	
DRIVE OUTPUT SECTION							
OUT Maximum Current	Source	I_{OUT}	$R_{BIAS}=200k\Omega$	28	36	44	mA
CURRENT SENSE SECTION							
Current Sense Threshold	V_{CS}		490	513	535	mV	
Pre-Current Sense	$V_{CS(PRE)}$		390	413	435	mV	
Leading Edge Blanking				500		ns	
FEEDBACK INPUT SECTION							
Feedback Pin Input Leakage Current	I_{FB}	$V_{FB}=4V$	1.8	2.4	3.0	μA	
Feedback Threshold	V_{FB}		3.97	4.03	4.09	V	
Enable Turn-on Voltage	$V_{FB(EN)}$		-2.0	-1.7	-1.4	V	
OUTPUT VOLTAGE COMPENSATION SECTION							
CPR Voltage	V_{CPR}	Dons (Tons/T): from 55% to 0.02%	1.5		3.5	V	
CPR Sink Current	I_{CPR}				200	μA	
PROTECTION SECTION							
Over Voltage Protection	$V_{FB(OVP)}$		7	8	9	V	



LOW-POWER OFF-LINE PRIMARY SIDE REGULATION CONTROLLER AP3768

Typical Performance Characteristics

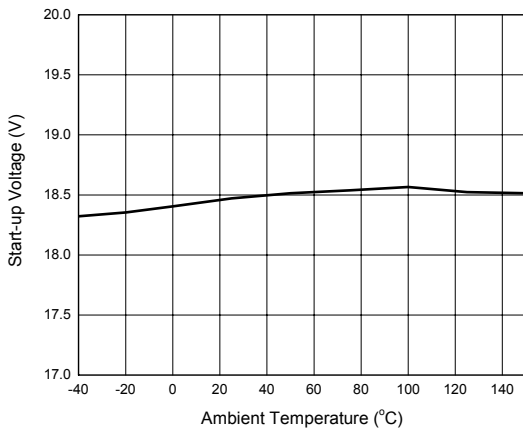

Figure 4. Start-up Voltage vs. Ambient Temperature

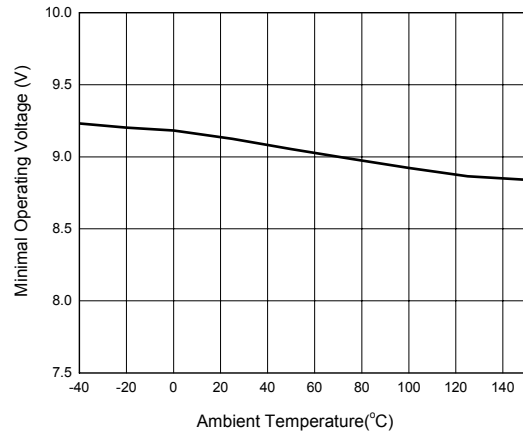

Figure 5. Minimal Operating Voltage vs. Ambient Temperature

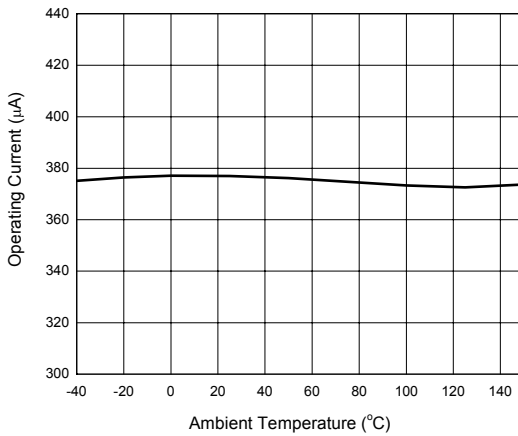

Figure 6. Operating Current vs. Ambient Temperature

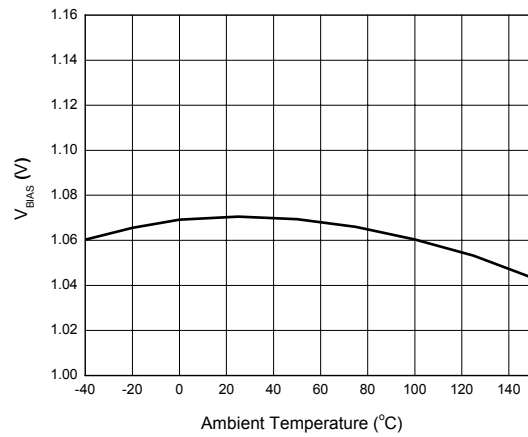

Figure 7. V_{BIAS} vs. Ambient Temperature



LOW-POWER OFF-LINE PRIMARY SIDE REGULATION CONTROLLER AP3768

Typical Performance Characteristics (Continued)

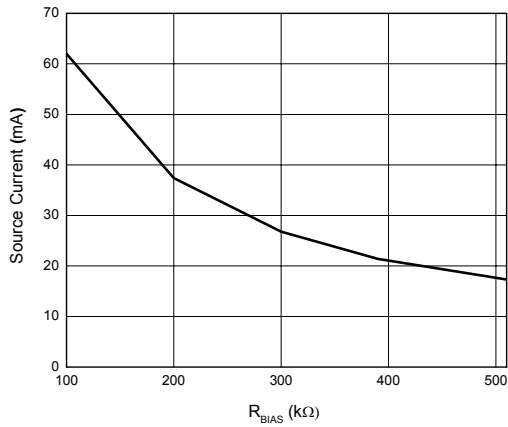

Figure 8. Source Current vs. R_{BIAS}

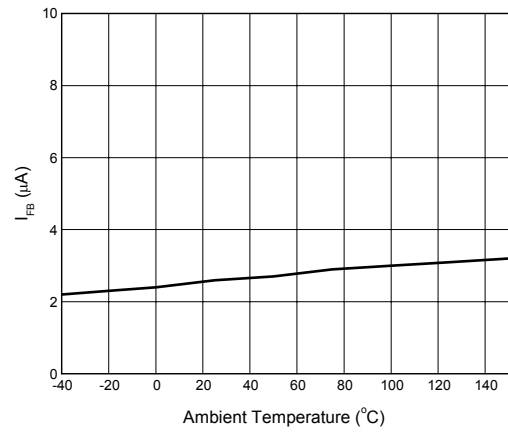

Figure 9. I_{FB} vs. Ambient Temperature

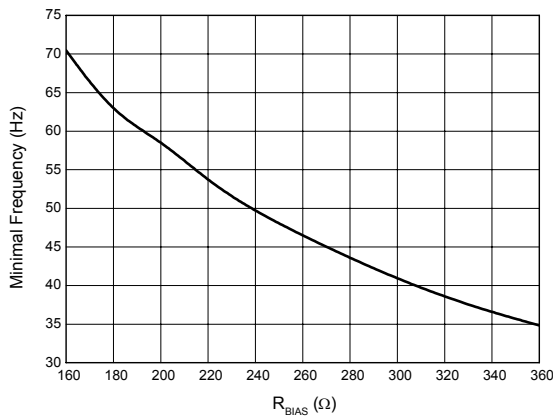

Figure 10. Minimal Frequency vs. R_{BIAS}



LOW-POWER OFF-LINE PRIMARY SIDE REGULATION CONTROLLER AP3768

Mechanical Dimensions

SOIC-8

Unit: mm(inch)

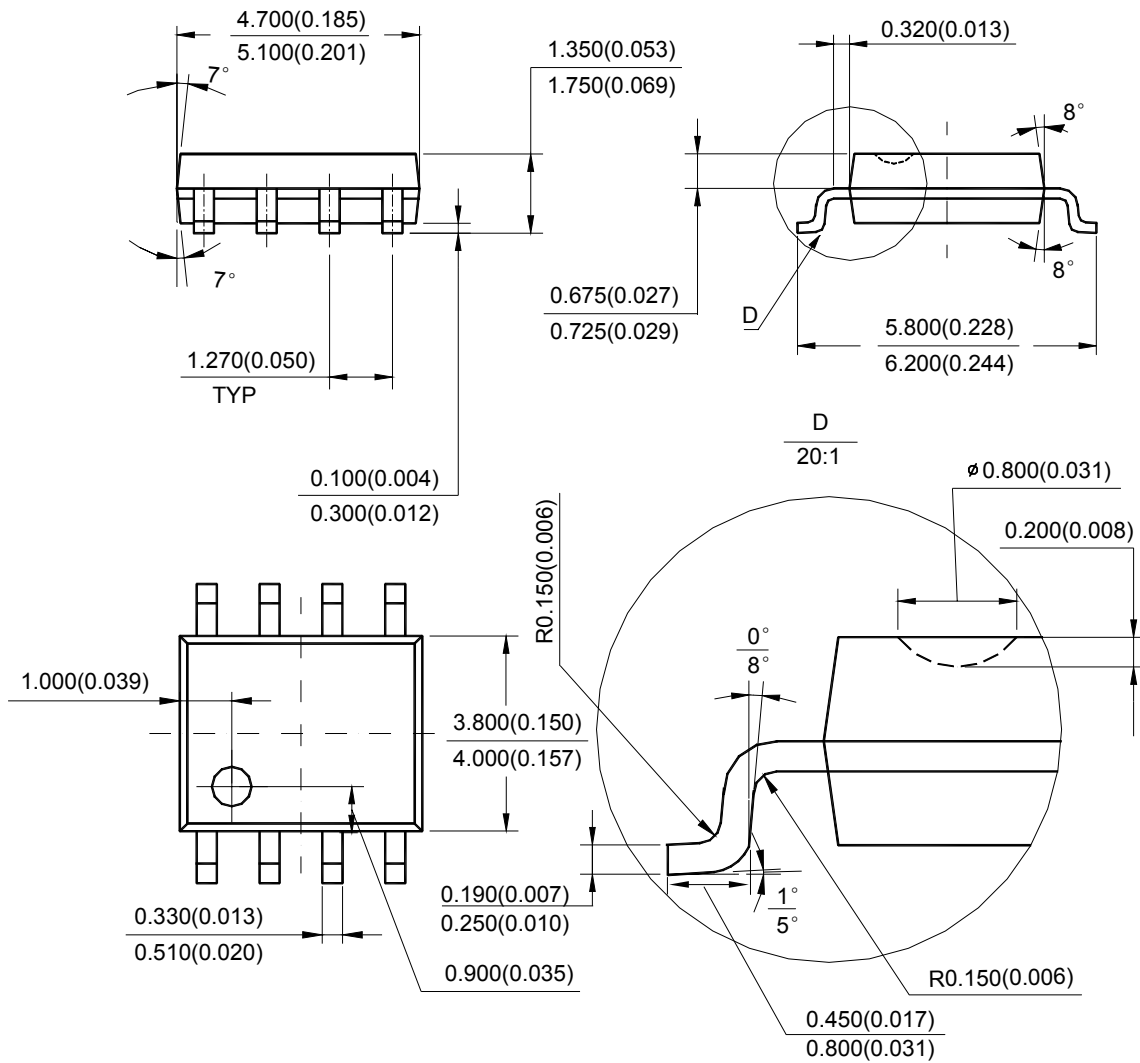

Note: Eject hole, oriented hole and mold mark is optional.



BCD Semiconductor Manufacturing Limited

<http://www.bcdsemi.com>

IMPORTANT NOTICE

BCD Semiconductor Manufacturing Limited reserves the right to make changes without further notice to any products or specifications herein. BCD Semiconductor Manufacturing Limited does not assume any responsibility for use of any its products for any particular purpose, nor does BCD Semiconductor Manufacturing Limited assume any liability arising out of the application or use of any its products or circuits. BCD Semiconductor Manufacturing Limited does not convey any license under its patent rights or other rights nor the rights of others.

MAIN SITE

- Headquarters

BCD Semiconductor Manufacturing Limited

No. 1600, Zi Xing Road, Shanghai ZiZhu Science-based Industrial Park, 200241, China
Tel: +86-21-24162266, Fax: +86-21-24162277

- Wafer Fab

Shanghai SIM-BCD Semiconductor Manufacturing Co., Ltd.

800 Yi Shan Road, Shanghai 200233, China
Tel: +86-21-6485 1491, Fax: +86-21-5450 0008

REGIONAL SALES OFFICE

Shenzhen Office

Shanghai SIM-BCD Semiconductor Manufacturing Co., Ltd., Shenzhen Office

Unit A Room 1203, Skyworth Bldg., Gaoxin Ave. 1.S., Nanshan District, Shenzhen, China
Tel: +86-755-8826 7951
Fax: +86-755-8826 7865

Taiwan Office

BCD Semiconductor (Taiwan) Company Limited

4F, 298-1, Rui Guang Road, Nei-Hu District, Taipei, Taiwan
Tel: +886-2-2656 2808
Fax: +886-2-2656 2806

USA Office

BCD Semiconductor Corp.

30920 Huntwood Ave. Hayward, CA 94544, USA
Tel : +1-510-324-2988
Fax: +1-510-324-2788