

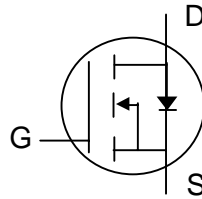

N-channel Enhancement-mode Power MOSFET

- Fast Switching Characteristics**
- Low Gate Charge**
- Simple Drive Requirement**
- RoHS-compliant, halogen-free**



BV_{DSS}	600V
$R_{DS(ON)}$	5Ω
I_D	400mA

Description

Advanced Power MOSFETs from APEC provide the designer with the best combination of fast switching, low on-resistance and cost-effectiveness.

The AP4002T-3 is in the popular TO-92 small through-hole package which is widely used in commercial and industrial applications where a small board footprint is required.

This device is well suited for use in low current applications such as small switching power supplies and load switches.

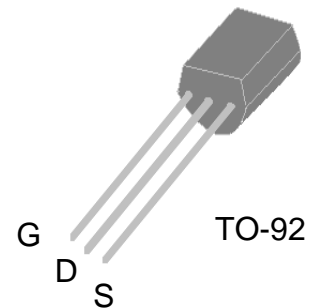

Absolute Maximum Ratings

Symbol	Parameter	Rating	Units
V_{DS}	Drain-Source Voltage	600	V
V_{GS}	Gate-Source Voltage	±30	V
I_D at $T_L=25^{\circ}C$	Continuous Drain Current	400	mA
I_{DM}	Pulsed Drain Current ¹	3	A
P_D at $T_L=25^{\circ}C$	Total Power Dissipation	2	W
	Linear Derating Factor	0.017	W/°C
E_{AS}	Single Pulse Avalanche Energy ²	20	mJ
I_{AR}	Avalanche Current	2	A
T_{STG}	Storage Temperature Range	-55 to 150	°C
T_J	Operating Junction Temperature Range	-55 to 150	°C

Thermal Data

Symbol	Parameter	Value	Unit
Rthj-a	Maximum Thermal Resistance, Junction-ambient	150	°C/W
Rthj-l	Maximum Thermal Resistance, Junction-lead	60	°C/W

Ordering Information

AP4002T-HF-3AP : in RoHS-compliant halogen-free TO-92, shipped on Ammopak, 2000pcs/reel



Electrical Specifications at $T_j=25^\circ\text{C}$ (unless otherwise specified)

Symbol	Parameter	Test Conditions	Min.	Typ.	Max.	Units
BV_{DSS}	Drain-Source Breakdown Voltage	$V_{GS}=0V, I_D=1mA$	600	-	-	V
$R_{DS(ON)}$	Static Drain-Source On-Resistance	$V_{GS}=10V, I_D=400mA$	-	-	5	Ω
$V_{GS(th)}$	Gate Threshold Voltage	$V_{DS}=V_{GS}, I_D=250\mu A$	2	-	4	V
g_{fs}	Forward Transconductance	$V_{DS}=10V, I_D=400mA$	-	570	-	mS
I_{DSS}	Drain-Source Leakage Current	$V_{DS}=600V, V_{GS}=0V$	-	-	100	μA
I_{GSS}	Gate-Source Leakage	$V_{GS}=\pm 30V$	-	-	± 1	μA
Q_g	Total Gate Charge ³	$I_D=2A$	-	12	19	nC
Q_{gs}	Gate-Source Charge	$V_{DS}=480V$	-	2	-	nC
Q_{gd}	Gate-Drain ("Miller") Charge	$V_{GS}=10V$	-	5.5	-	nC
$t_{d(on)}$	Turn-on Delay Time ³	$V_{DD}=200V$	-	10	-	ns
t_r	Rise Time	$I_D=1A$	-	12	-	ns
$t_{d(off)}$	Turn-off Delay Time	$R_G=50\Omega, V_{GS}=10V$	-	52	-	ns
t_f	Fall Time	$R_D=200\Omega$	-	19	-	ns
C_{iss}	Input Capacitance	$V_{GS}=0V$	-	375	600	pF
C_{oss}	Output Capacitance	$V_{DS}=10V$	-	170	-	pF
C_{rss}	Reverse Transfer Capacitance	$f=1.0MHz$	-	45	-	pF

Source-Drain Diode

Symbol	Parameter	Test Conditions	Min.	Typ.	Max.	Units
V_{SD}	Forward On Voltage ³	$T_j=25^\circ\text{C}, I_S=2A, V_{GS}=0V$	-	-	1.5	V
t_{rr}	Reverse Recovery Time ³	$I_S=2A, V_{GS}=0V$	-	340	-	ns
Q_{rr}	Reverse Recovery Charge	$di/dt=100A/\mu s$	-	2.2	-	μC

Notes:

1. Pulse width limited by maximum junction temperature.
2. Starting $T_j=25^\circ\text{C}$, $V_{DD}=50V$, $L=10mH$, $R_G=25\Omega$
3. Pulse test

THIS PRODUCT IS SENSITIVE TO ELECTROSTATIC DISCHARGE, PLEASE HANDLE WITH CAUTION.

USE OF THIS PRODUCT AS A CRITICAL COMPONENT IN LIFE SUPPORT OR OTHER SIMILAR SYSTEMS IS NOT AUTHORIZED.

APEC DOES NOT ASSUME ANY LIABILITY ARISING OUT OF THE APPLICATION OR USE OF ANY PRODUCT OR CIRCUIT DESCRIBED HEREIN; NEITHER DOES IT CONVEY ANY LICENSE UNDER ITS PATENT RIGHTS, NOR THE RIGHTS OF OTHERS.

APEC RESERVES THE RIGHT TO MAKE CHANGES WITHOUT FURTHER NOTICE TO ANY PRODUCTS HEREIN TO IMPROVE



Typical Electrical Characteristics

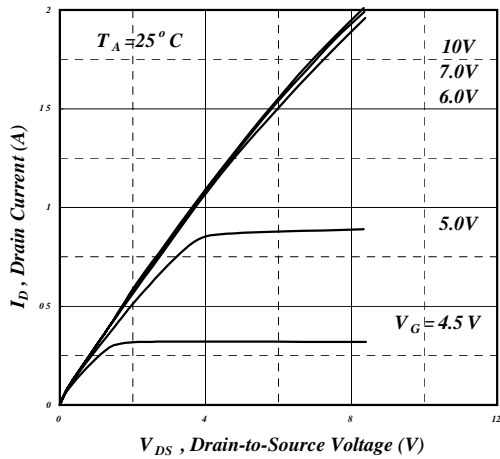

Fig 1. Typical Output Characteristics

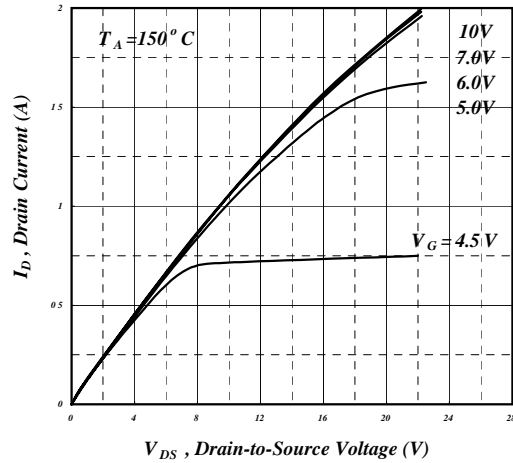

Fig 2. Typical Output Characteristics

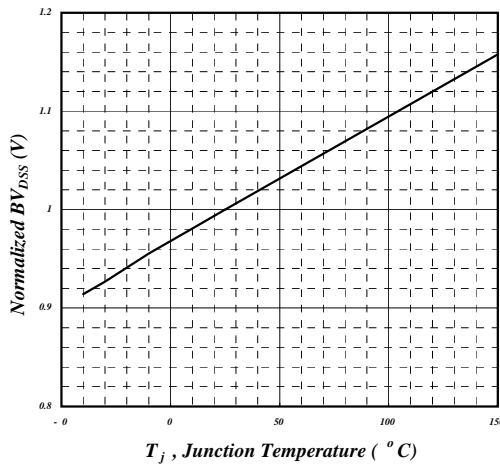

Fig 3. Normalised BVDSS vs. Junction Temperature

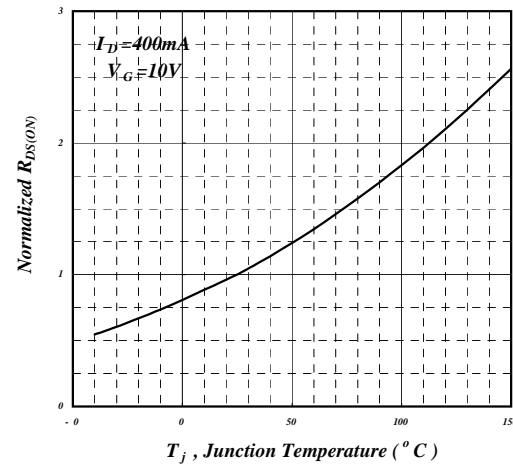

Fig 4. Normalized On-Resistance vs. Junction Temperature

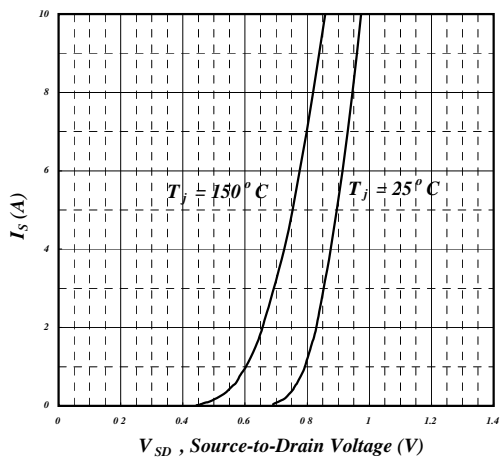

Fig 5. Forward Characteristic of Reverse Diode

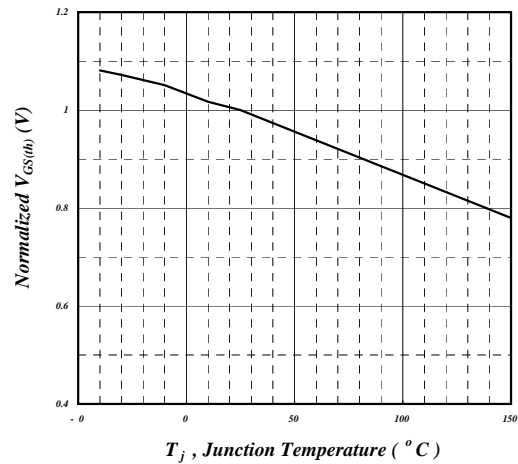

Fig 6. Gate Threshold Voltage vs. Junction Temperature



Typical Electrical Characteristics (cont.)

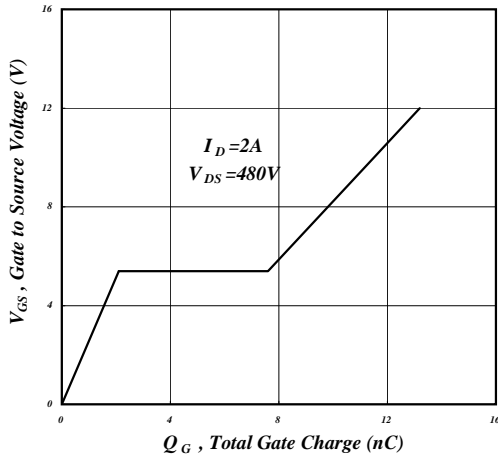

Fig 7. Gate Charge Characteristics

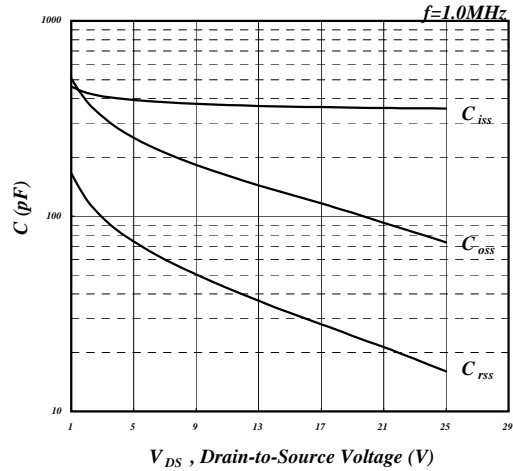

Fig 8. Typical Capacitance Characteristics

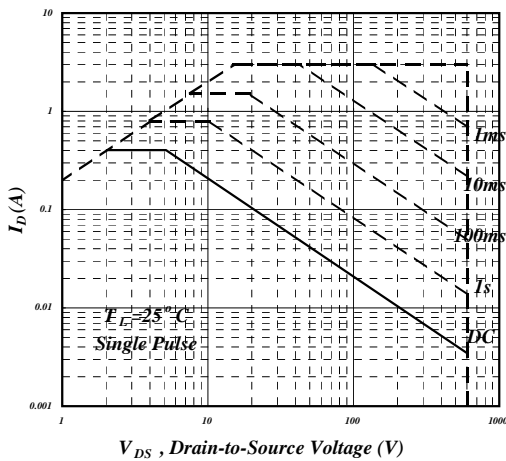

Fig 9. Maximum Safe Operating Area

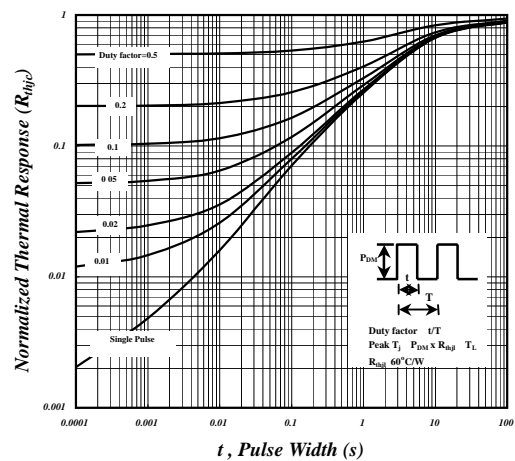

Fig 10. Effective Transient Thermal Impedance

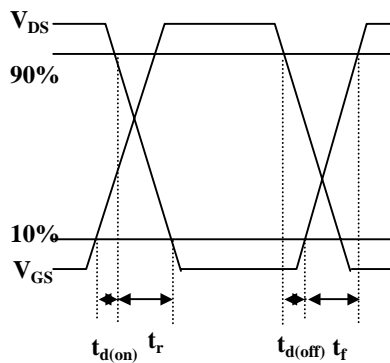

Fig 11. Switching Time Waveform

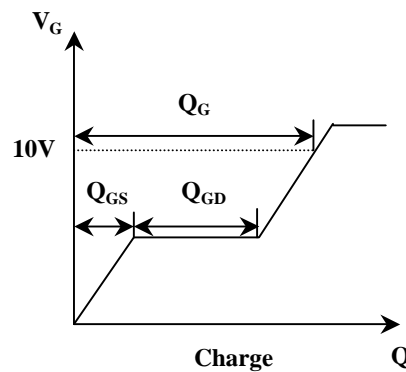
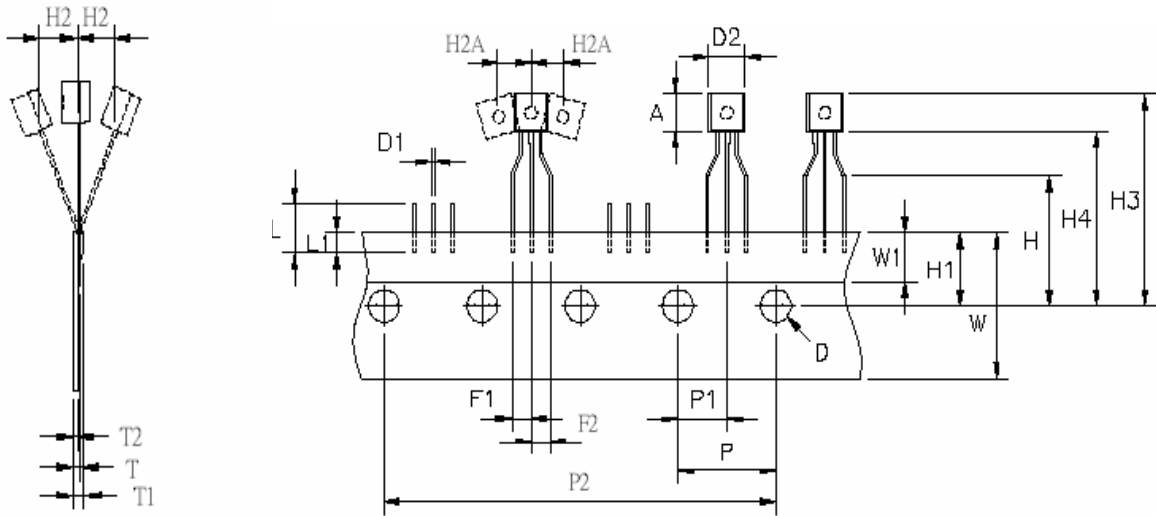

Fig 12. Gate Charge Waveform



Package Dimensions: TO-92



SYMBOL	A	D	D1	D2	F1,F2	F1-F2	H	H1
mm	3.18~12	4.0±0.2	0.36~0.53	9.0 max.	2.5 ^{+0.2} _{-0.1}	±0.30	16±0.5	9±0.5
SYMBOL	H2	H2A	H3	H4	L	L1	P	P1
mm	1 max.	1 max.	27 max.	21 max.	11 max.	2.5 min.	12.7±0.2	5.95~6.75
SYMBOL	P2	T	T1	T2	W	W1		
mm	50.3~51.30	0.55 max.	1.42 max.	0.38~0.68	17.5~19.0	5.0~7.0		

1. All dimensions are in millimeters.
2. Dimensions do not include mold protrusions.

Marking Information:

