

### Description

The AP5100 is a current mode step-down converter with a built-in power MOSFET to enable smallest solution size power conversion.

With the low series resistance power switch it enables a constant output current of up to 1.2A over a wide input supply range. The load and line regulation has excellent response time over the operating input voltage and temperature range.

The AP5100 is self protected, through a cycle-by-cycle current limiting algorithm and an on chip thermal protection.

The AP5100 will provide the voltage conversion with a low count of widely available standard external components.

The AP5100 is available in SOT26 package.

### Features

- $V_{IN}$  4.75V to 24V
- Load current of up to 1.2A
- Internal Power MOSFET
- Stable with Low ESR Ceramic Output Capacitors
- Up to 90% Efficiency
- 0.1 $\mu$ A Shutdown Mode
- Fixed 1.4MHz Frequency
- Thermal Shutdown
- Cycle-by-Cycle Over Current Protection
- Resistor divider adjustable Output: 0.81V to 15V
- SOT26: Available in "Green" Molding Compound (No Br, Sb)
- Lead Free Finish/RoHS Compliant (Note 1)

Notes: 1. EU Directive 2002/95/EC (RoHS). All applicable RoHS exemptions applied. Please visit our website at [http://www.diodes.com/products/lead\\_free.html](http://www.diodes.com/products/lead_free.html).

### Pin Assignments

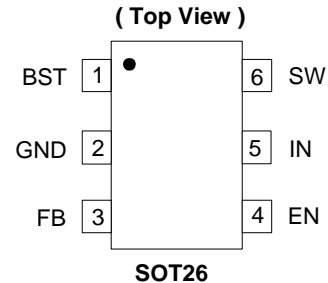

### Applications

- Distributed Power Systems
- Battery Charger
- Pre-Regulator for Linear Regulators
- WLED Drivers

### Typical Application Circuit

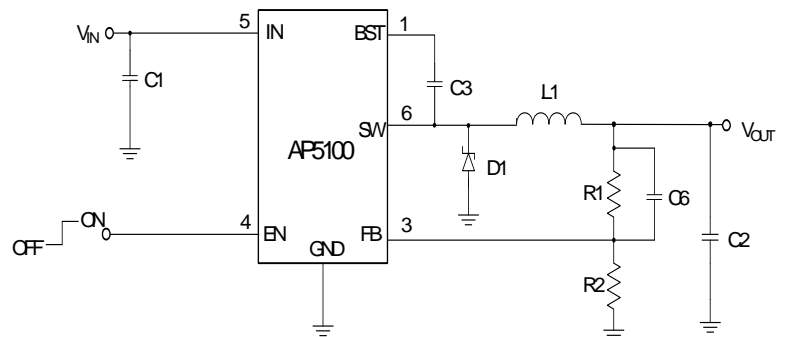
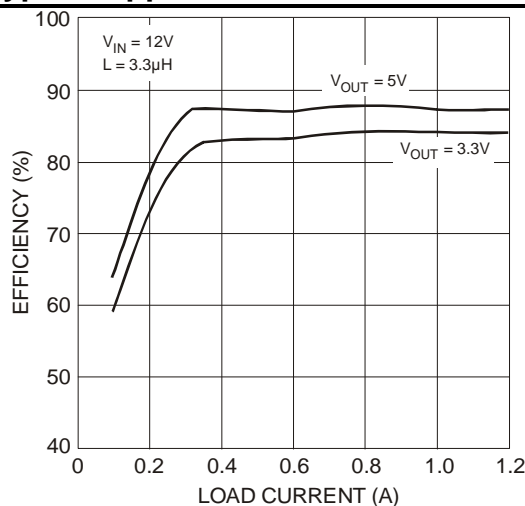
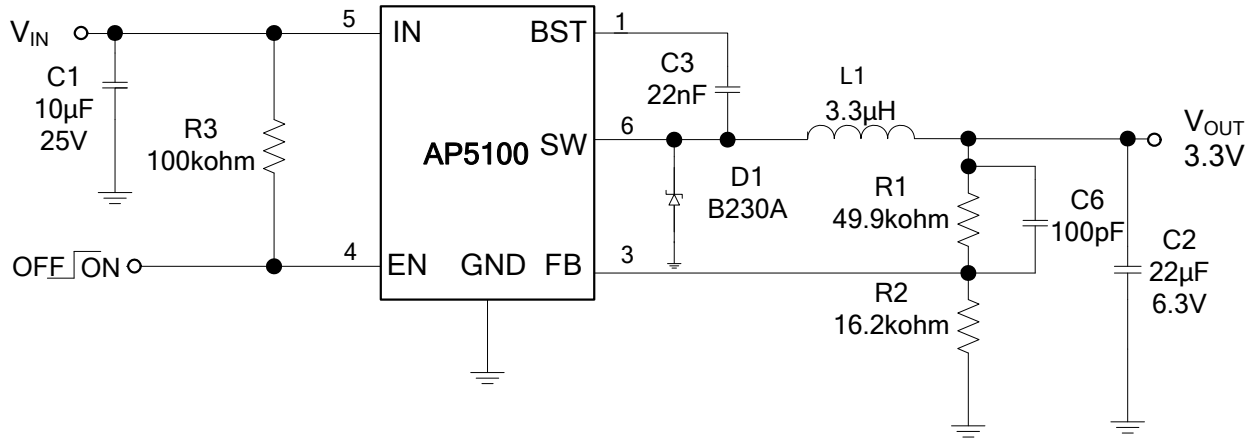
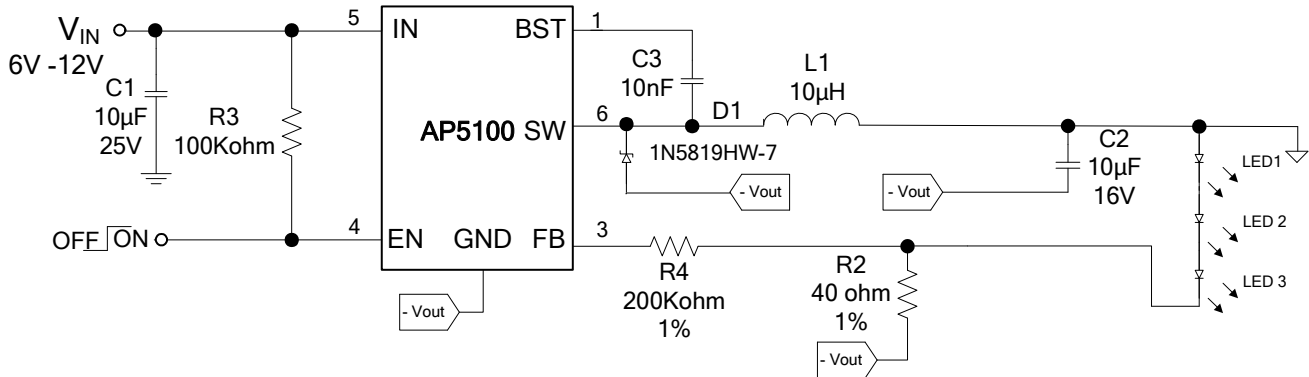

Figure 2. Typical Application Circuit

**Typical Application Circuit (cont.)**



**Figure 3. 1.4MHz, 3.3V Output at 1A Step-Down Converter**

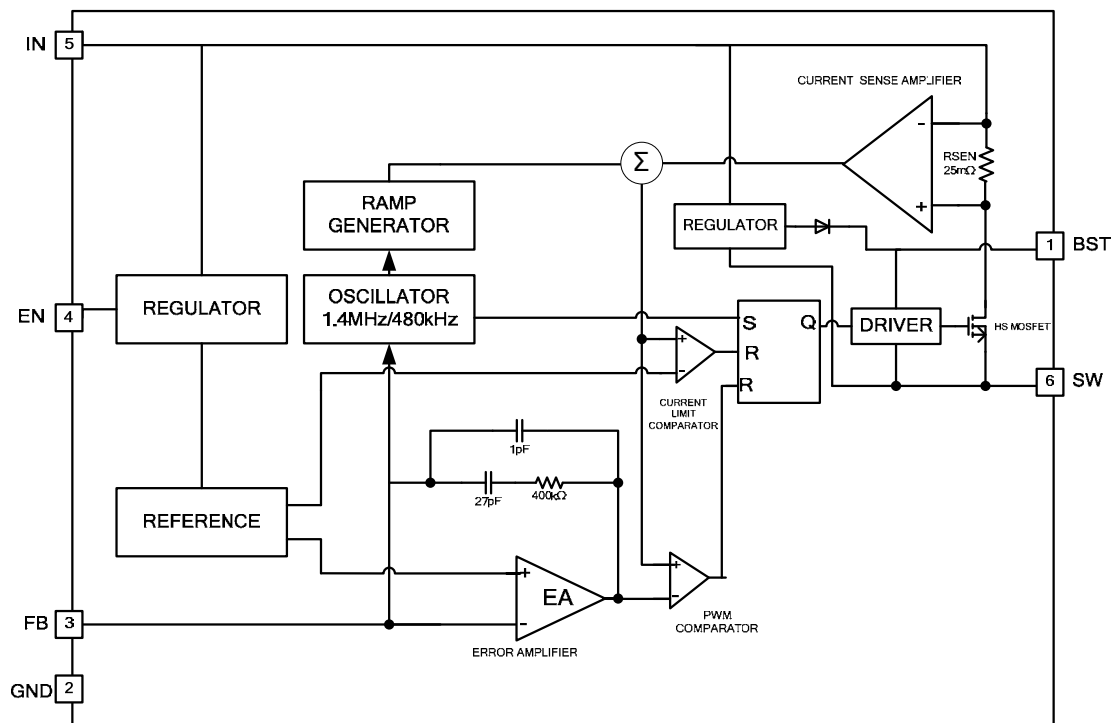

**Figure 4. White LED Driver Application**

**Pin Descriptions**

Pin Name	Pin #	Description
BST	1	Bootstrap. To form a boost circuit, a capacitor is connected between SW and BST pins to form a floating supply across the power switch driver. This capacitor is needed to drive the power switch's gate above the supply voltage. Typical values for $C_{BST}$ range from 0.1 $\mu$ F to 1 $\mu$ F.
GND	2	Ground. This pin is the voltage reference for the regulated output voltage. All control circuits are referenced to this pin. For this reason care must be taken in its layout.
FB	3	Feedback. To set the output voltage, connect this pin to the output resistor divider or directly to $V_{OUT}$ . To prevent current limit run away during a current limit condition, the frequency foldback comparator lowers the oscillator frequency when the FB voltage is below 400mV.
EN	4	On/Off Control Input. Do not leave this pin floating. To turn the device ON, pull EN above 1.2V and to turn it off pull below 0.4V. If enable/disable is not used, connect a 100k $\Omega$ resistor between EN to $V_{IN}$ .
IN	5	Supply Voltage. The AP5100 operates from a +4.75V to +24V unregulated input. A decoupling capacitor C1 is required to prevent large voltage spikes from appearing at the input. Place this capacitor near the IC.
SW	6	Switch Output. This is the reference for the floating top gate driver.

**Functional Block Diagram**



**Figure 5. Functional Block Diagram**

### Absolute Maximum Ratings (Note 2)

Symbol	Description	Rating	Unit
ESD HBM	Human Body Model ESD Protection	3	KV
ESD MM	Machine Model ESD Protection	300	V
$V_{IN}$	Supply Voltage	26	V
$V_{SW}$	Switch Voltage	-0.3 to $V_{IN} + 0.3$	V
$V_{BST}$	Boost Voltage	$V_{SW} + 6$	V
	All Other Pins	-0.3 to +6	V
$T_{ST}$	Storage Temperature	-65 to +150	°C
$T_J$	Junction Temperature	+150	°C
$T_L$	Lead Temperature	+260	°C
$\theta_{JA}$	Junction to Ambient Thermal Resistance (Note 3)	140	°C/W
$\theta_{JC}$	Junction to Case Thermal Resistance (Note 3)	35	°C/W

Notes: 2. Exceeding these ratings may damage the device.  
 3. Test condition for SOT26: Measured on approximately 1" square of 1 oz copper.

### Recommended Operating Conditions (Note 4)

Symbol	Description	Rating	Unit
$V_{IN}$	Supply Voltage	4.75 to 24	°C
$T_A$	Operating Ambient Temperature Range	-25 to +85	°C
$V_{OUT}$	Output Voltage	0.81 to 15	V

Note: 4. The device function is not guaranteed outside of the recommended operating conditions.

**Electrical Characteristics ( $V_{IN} = 12V$ ,  $T_A = +25^\circ C$ , unless otherwise noted)**

Symbol	Parameter	Test Conditions	Min	Typ.	Max	Unit
$V_{FB}$	Feedback Voltage	$4.75V \leq V_{IN} \leq 24V$	0.790	0.810	0.830	V
$I_{FB}$	Feedback Current	$V_{FB} = 0.8V$		0.1		$\mu A$
$R_{DS(ON)}$	Switch-On Resistance (Note 5)			0.35		$\Omega$
	Switch Leakage	$V_{EN} = 0V, V_{SW} = 0V$			10	$\mu A$
	Current Limit (Note 5)			2.4		A
$f_{SW}$	Oscillator Frequency	$V_{FB} = 0.6V$	1.1	1.4	1.7	MHz
	Fold-back Frequency	$V_{FB} = 0V$		480		kHz
	Maximum Duty Cycle	$V_{FB} = 0.6V$		87		%
$t_{ON}$	Minimum On-Time (Note 5)			100		ns
	Under Voltage Lockout Threshold Rising		3.8	4.0	4.2	V
	Under Voltage Lockout Threshold Hysteresis			150		mV
	EN Input Low Voltage				0.4	V
	EN Input High Voltage		1.2			V
	EN Input Current	$V_{EN} = 2V$		0.3		$\mu A$
		$V_{EN} = 0V$		0.1		
$I_S$	Supply Current (Shutdown)	$V_{EN} = 0V$		0.1	1.0	$\mu A$
$I_Q$	Supply Current (Quiescent)	$V_{EN} = 2V, V_{FB} = 1V$		0.4	1.0	mA
	Thermal Shutdown (Note 5)			140		$^\circ C$

Note: 5. Guaranteed by design.

**Typical Performance Characteristics**

$V_{IN} = 12V$ ,  $V_{OUT} = 3.3V$ ,  $L = 3.3\mu H$ ,  $C1 = 10\mu F$ ,  $C2 = 22\mu F$ ,  $T_A = +25^\circ C$ , unless otherwise noted.

**Steady State Test**  
**( $I_{OUT} = 0.5A$ )**

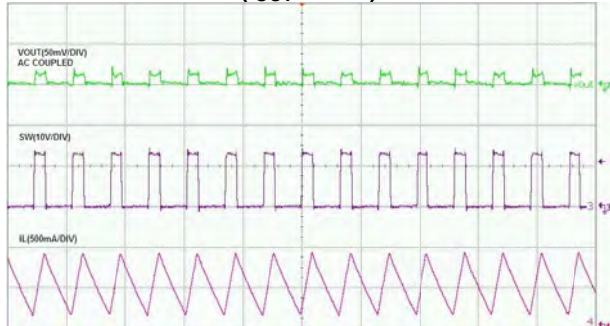

Time- 1 $\mu s$ /div

**Load Transient Test**  
**( $I_{OUT} = 0.2A$  to  $0.8A$ . Step at  $0.8A/\mu s$ )**

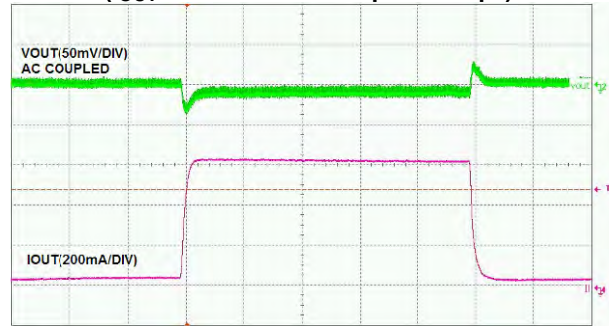

Time- 100 $\mu s$ /div

**Start-up Through Enable**  
**(No Load)**

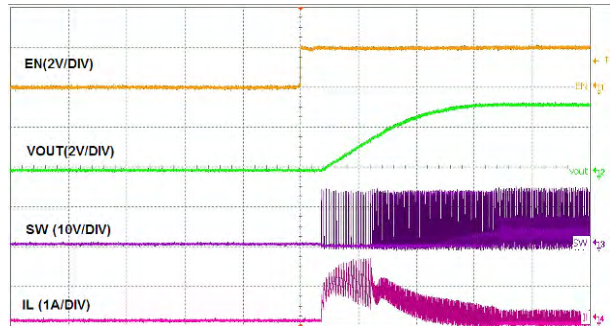

Time- 50 $\mu s$ /div

**Start-up through Enable**  
**( $I_{OUT} = 1A$ , resistive load)**

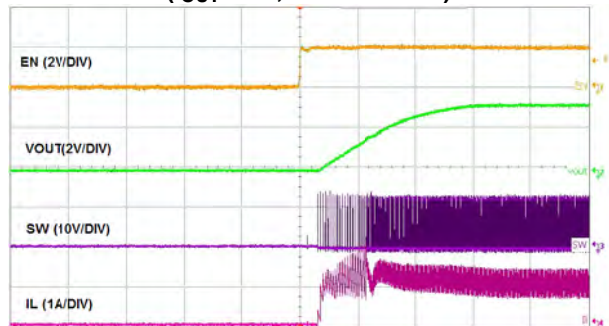

Time- 50 $\mu s$ /div

**Shutdown Through Enable**  
**(No Load)**

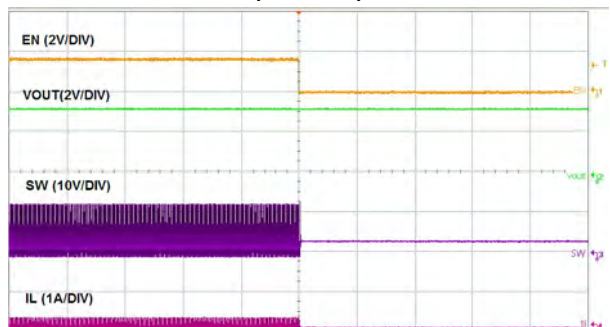

Time- 50 $\mu s$ /div

**Shutdown Through Enable**  
**( $I_{OUT} = 1A$ , resistive load)**

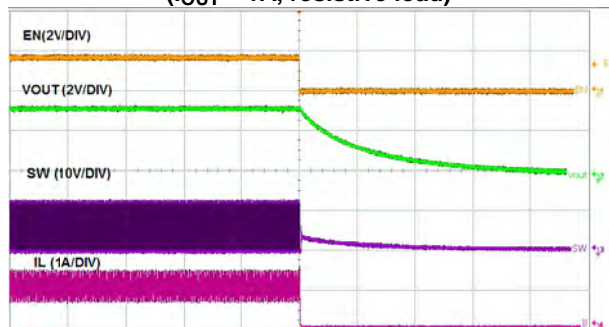

Time- 50 $\mu s$ /div

**Typical Performance Characteristics (cont.)**

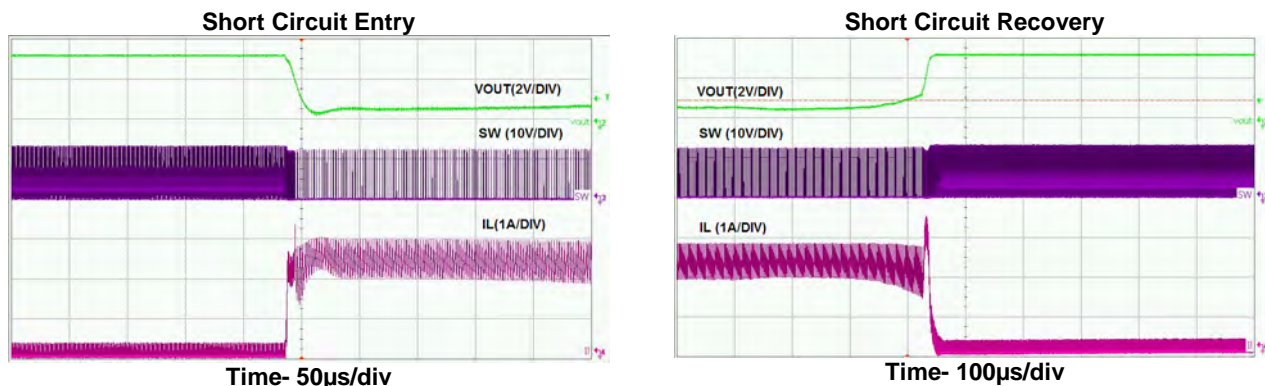

**Applications Information**

**OPERATION**

The AP5100 is a current mode control, asynchronous buck regulator. Current mode control assures excellent line and load regulation and a wide loop bandwidth for fast response to load transients. Figure. 4 depicts the functional block diagram of AP5100.

The operation of one switching cycle can be explained as follows. At the beginning of each cycle, HS (high-side) MOSFET is off. The EA output voltage is higher than the current sense amplifier output, and the current comparator's output is low. The rising edge of the 1.4MHz oscillator clock signal sets the RS Flip-Flop. Its output turns on HS MOSFET.

When the HS MOSFET is on, inductor current starts to increase. The Current Sense Amplifier senses and amplifies the inductor current. Since the current mode control is subject to sub-harmonic oscillations that peak at half the switching frequency, Ramp slope compensation is utilized. This will help to stabilize the power supply. This Ramp compensation is summed to the Current Sense Amplifier output and compared to the Error Amplifier output by the PWM Comparator. When the sum of the Current Sense Amplifier output and the Slope Compensation signal exceeds the EA output voltage, the RS Flip-Flop is reset and HS MOSFET is turned off. The external Schottky rectifier diode (D1) conducts the inductor current.

For one whole cycle, if the sum of the Current Sense Amplifier output and the Slope Compensation signal does not exceed the EA output, then the falling edge of the oscillator clock resets the Flip-Flop. The output of the Error Amplifier increases when feedback voltage (VFB) is lower than the reference voltage of 0.81V. This also increases the inductor current as it is proportional to the EA voltage.

**Setting the Output Voltage**

The output voltage can be adjusted from 0.81V to 15V using an external resistor divider. Table 1 shows a list of resistor selection for common output voltages. Resistor R1 is selected based on a design tradeoff between efficiency and output voltage accuracy. For high values of R1 there is less current consumption in the feedback network. However the trade off is output voltage accuracy due to the bias current in the error amplifier. R2 can be determined by the following equation:

$$R_1 = R_2 \times \left( \frac{V_{OUT}}{0.81} - 1 \right)$$

**Equation 1**

V <sub>OUT</sub> (V)	R <sub>1</sub> (kΩ)	R <sub>2</sub> (kΩ)
1.8	80.6 (1%)	64.9 (1%)
2.5	49.9 (1%)	23.7 (1%)
3.3	49.9 (1%)	16.2 (1%)
5	49.9 (1%)	9.53 (1%)

**Table 1. Resistor Selection for Common Output Voltages**

$$L = \frac{V_{OUT} \times (V_{IN} - V_{OUT})}{V_{IN} \times \Delta I_L \times f_{SW}}$$

**Equation 2**

Where ΔI<sub>L</sub> is the inductor ripple current.  
And f<sub>SW</sub> is the buck converter switching frequency.

**Applications Information (cont.)**

**Setting the Output Voltage (cont.)**

Choose the inductor ripple current to be 30% of the maximum load current. The maximum inductor peak current is calculated from:

$$I_{L(MAX)} = I_{LOAD} + \frac{\Delta I_L}{2}$$

**Equation 3**

Peak current determines the required saturation current rating, which influences the size of the inductor. Saturating the inductor decreases the converter efficiency while increasing the temperatures of the inductor, the MOSFET and the diode. Hence choosing an inductor with appropriate saturation current rating is important.

A 1µH to 10µH inductor with a DC current rating of at least 25% percent higher than the maximum load current is recommended for most applications.

For highest efficiency, the inductor's DC resistance should be less than 200mΩ. Use a larger inductance for improved efficiency under light load conditions.

**Input Capacitor**

The input capacitor reduces the surge current drawn from the input supply and the switching noise from the device. The input capacitor has to sustain the ripple current produced during the on time on the upper MOSFET. It must hence have a low ESR to minimize the losses.

Due to large di/dt through the input capacitors, electrolytic or ceramics should be used. If a tantalum must be used, it must be surge protected. Otherwise, capacitor failure could occur. For most applications, a 4.7µF ceramic capacitor is sufficient.

**Output Capacitor**

The output capacitor keeps the output voltage ripple small, ensures feedback loop stability and reduces the overshoot of the output voltage. The output capacitor is a basic component for the fast response of the power supply. In fact, during load transient, for the first few microseconds it supplies the current to the load. The converter recognizes the load transient and sets the duty cycle to maximum, but the current slope is limited by the inductor value.

Maximum capacitance required can be calculated from the following equation:

$$C_o = \frac{L(I_{OUT} + \frac{\Delta I_{inductor}}{2})^2}{(\Delta V + V_{OUT})^2 - V_{OUT}^2}$$

**Equation 4**

Where ΔV is the maximum output voltage overshoot.  
Where ΔI<sub>inductor</sub> is the inductor ripple current.

ESR of the output capacitor dominates the output voltage ripple. The amount of ripple can be calculated from the equation below:

$$V_{out\_capacitor} = \Delta I_{inductor} \times ESR$$

An output capacitor with ample capacitance and low ESR is the best option. For most applications, a 22µF ceramic capacitor will be sufficient.

**External Diode**

The external diode's forward current must not exceed the maximum output current. Since power dissipation is a critical factor when choosing a diode, it can be calculated from the equation below:

$$P_{diode} = (1 - \frac{V_{OUT}}{V_{IN}}) \times I_{out} \times 0.3V$$

**Equation 5**

Note: 0.3V is the voltage drop across the schottky diode. A diode that can withstand this power dissipation must be chosen.

**External Bootstrap Diode**

It is recommended that an external bootstrap diode be added when the input voltage is no greater than 5V or the 5V rail is available in the system. This helps improve the efficiency of the regulator. The bootstrap diode can be a low cost one such as IN4148 or BAT54.

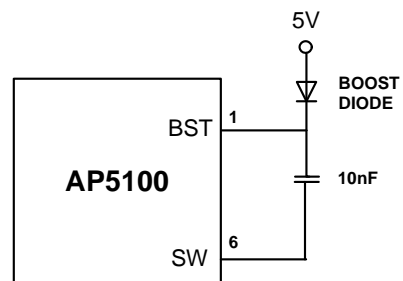

**Figure 6. External Bootstrap Diode**

**Under Voltage Lockout (UVLO)**

Under Voltage Lockout is implemented to prevent the IC malfunction from insufficient input voltages. For power-up, the AP5100 must be enabled and the input voltage must be higher than the UVLO rising threshold (4.0 V typ). When the input voltage falls below the UVLO falling threshold (UVLO rising threshold – UVLO hysteresis), the AP5100 will latch an under voltage fault. In this event, the output will fall low. To resume normal operation, the AP5100 must be pulled above the UVLO rising threshold.



---

**Applications Information (cont.)**

---

**Internal Soft Start**

Soft start is traditionally implemented to prevent the excess inrush current. This in turn prevents the converter output voltage from overshooting when it reaches regulation. The AP5100 has an internal current source with a soft start capacitor to ramp the reference voltage from 0V to 0.810V. The soft start time is internally fixed at 200us (TYP). The soft start sequence is reset when there is a Thermal Shutdown, Under Voltage Lockout (UVLO) or when the part is disabled using the EN pin.

**Current Limit**

The AP5100 has cycle-by-cycle current limiting implementation. The voltage drop across the internal high-side mosfet is sensed and compared with the internally set current limit threshold. This voltage drop is sensed at about 30ns after the HS turns on. When the peak inductor current exceeds the set current limit threshold, current limit protection is activated. During this time the feedback voltage (VFB) drops down. When the voltage at the FB pin reaches 0.4V, the internal oscillator shifts the frequency from the normal operating frequency of 1.4MHz to a fold-back frequency of 480kHz. The current limit is reduced to 70% of nominal current limit when the part is operating at 480kHz. This low Fold-back frequency prevents runaway current.

**Thermal Shutdown**

The AP5100 has on-chip thermal protection that prevents damage to the IC when the die temperature exceeds safe margins. It implements a thermal sensing to monitor the operating junction temperature of the IC. Once the die temperature rises to approximately 140°C, the thermal protection feature gets activated. The internal thermal sense circuitry turns the IC off thus preventing the power switch from damage.

A hysteresis in the thermal sense circuit allows the device to cool down to approximately 120°C before the IC is enabled again. This thermal hysteresis feature prevents undesirable oscillations of the thermal protection circuit.

**PC Board Layout**

This is a high switching frequency converter. Hence attention must be paid to the switching currents interference in the layout. Switching current from one power device to another can generate voltage transients across the impedances of the interconnecting bond wires and circuit traces. These interconnecting impedances should be minimized by using wide, short printed circuit traces. The input capacitor needs to be as close as possible to the IN and GND pins. The external feedback resistors should be placed next to the FB pin.

**Ordering Information**

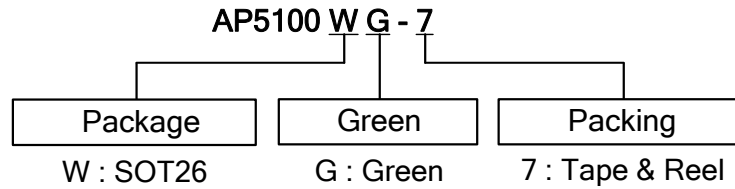

Device	Package Code	Packaging (Note 6)	13" Tape and Reel	
			Quantity	Part Number Suffix
AP5100WG-7	W	SOT26	3000/Tape & Reel	-7



Note: 6. Pad layout as shown on Diodes Inc. suggested pad layout document AP02001, which can be found on our website at <http://www.diodes.com/datasheets/ap02001.pdf>.

**Marking Information**

**SOT26**

( Top View )

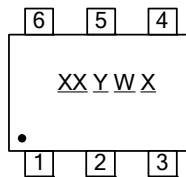

XX : Identification Code  
Y : Year 0~9  
W : Week : A~Z : 1~26 week;  
           a~z : 27~52 week; z represents  
           52 and 53 week  
X : A~Z : Green

Part Number	Package	Identification Code
AP5100W	SOT26	AJ

**Package Outline Dimensions (All Dimensions in mm)**

SOT26

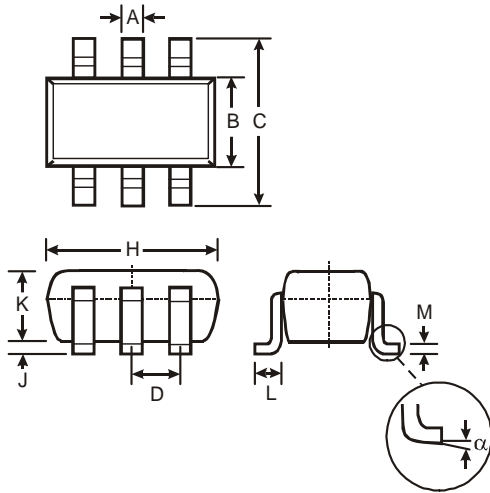

SOT26			
Dim	Min	Max	Typ
A	0.35	0.50	0.38
B	1.50	1.70	1.60
C	2.70	3.00	2.80
D	—	—	0.95
H	2.90	3.10	3.00
J	0.013	0.10	0.05
K	1.00	1.30	1.10
L	0.35	0.55	0.40
M	0.10	0.20	0.15
α	0°	8°	—
All Dimensions in mm			

**Suggested Pad Layout**

SOT26

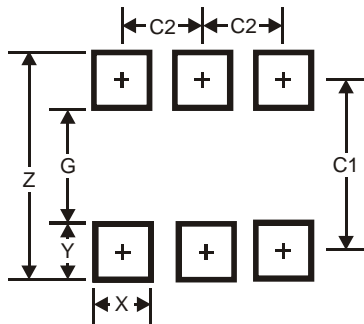

Dimensions	Value (in mm)
Z	3.20
G	1.60
X	0.55
Y	0.80
C1	2.40
C2	0.95

**IMPORTANT NOTICE**

DIODES INCORPORATED MAKES NO WARRANTY OF ANY KIND, EXPRESS OR IMPLIED, WITH REGARDS TO THIS DOCUMENT, INCLUDING, BUT NOT LIMITED TO, THE IMPLIED WARRANTIES OF MERCHANTABILITY AND FITNESS FOR A PARTICULAR PURPOSE (AND THEIR EQUIVALENTS UNDER THE LAWS OF ANY JURISDICTION).

Diodes Incorporated and its subsidiaries reserve the right to make modifications, enhancements, improvements, corrections or other changes without further notice to this document and any product described herein. Diodes Incorporated does not assume any liability arising out of the application or use of this document or any product described herein; neither does Diodes Incorporated convey any license under its patent or trademark rights, nor the rights of others. Any Customer or user of this document or products described herein in such applications shall assume all risks of such use and will agree to hold Diodes Incorporated and all the companies whose products are represented on Diodes Incorporated website, harmless against all damages.

Diodes Incorporated does not warrant or accept any liability whatsoever in respect of any products purchased through unauthorized sales channel.

Should Customers purchase or use Diodes Incorporated products for any unintended or unauthorized application, Customers shall indemnify and hold Diodes Incorporated and its representatives harmless against all claims, damages, expenses, and attorney fees arising out of, directly or indirectly, any claim of personal injury or death associated with such unintended or unauthorized application.

Products described herein may be covered by one or more United States, international or foreign patents pending. Product names and markings noted herein may also be covered by one or more United States, international or foreign trademarks.

**LIFE SUPPORT**

Diodes Incorporated products are specifically not authorized for use as critical components in life support devices or systems without the express written approval of the Chief Executive Officer of Diodes Incorporated. As used herein:

A. Life support devices or systems are devices or systems which:

1. are intended to implant into the body, or
2. support or sustain life and whose failure to perform when properly used in accordance with instructions for use provided in the labeling can be reasonably expected to result in significant injury to the user.

B. A critical component is any component in a life support device or system whose failure to perform can be reasonably expected to cause the failure of the life support device or to affect its safety or effectiveness.

Customers represent that they have all necessary expertise in the safety and regulatory ramifications of their life support devices or systems, and acknowledge and agree that they are solely responsible for all legal, regulatory and safety-related requirements concerning their products and any use of Diodes Incorporated products in such safety-critical, life support devices or systems, notwithstanding any devices- or systems-related information or support that may be provided by Diodes Incorporated. Further, Customers must fully indemnify Diodes Incorporated and its representatives against any damages arising out of the use of Diodes Incorporated products in such safety-critical, life support devices or systems.

Copyright © 2012, Diodes Incorporated

[www.diodes.com](http://www.diodes.com)