



DESCRIPTION

The AP8007 is a high performance AC-DC off-line controller for low power battery charger and adapter applications with Universal-input. It uses Pulse Frequency and Width Modulation (PFWM) method to build discontinuous conduction mode (DCM) flyback power supplies.

The AP8007 utilizes primary-side sensing and regulation technology to provide accurate constant voltage, constant current (CV/CC) regulation without requiring an opto-coupler and secondary control circuitry. It also eliminates the need of external loop compensation circuitry while maintaining stability. The AP8007 achieves excellent regulation and high average efficiency, yet meets the requirement for standby power less than 150mW.

The AP8007 ensures safe operation with complete protection against all fault conditions. Built-in protection circuitry is provided for output short circuit, output over-voltage, line under-voltage, V_{DD} over voltage, feedback open and short, and over temperature conditions.

Integrated line and primary inductance compensation circuitry, the AP8007 provides accurate constant current operation despite wide variations in line voltage and primary inductance. It has the built-in cable voltage drop compensation function.

The AP8007 is available in SOT-25 package.

ORDERING INFORMATION

Package Type	Part Number	
SOT-25	E5	AP8007E5R
		AP8007E5VR
Note	R: Tape & Reel V: Halogen free Package	
AiT provides all RoHS products Suffix "V" means Halogen free Package		

FEATURES

- Primary Side Regulation Technology for Eliminating Opto-coupler and Secondary CV/CC Control Circuitry
- Best-in-Class Constant Voltage, Constant Current Accuracy
- Built-in Soft-Start Circuit
- Integrated Line and Primary Inductance Compensation
- Integrated Output Cable Voltage Drop Compensation
- Line Under-Voltage, Output Over-Voltage, Output Short-Circuit and Over-Temperature Protection
- Minimum External Components
- Low EMI
- Available in SOT-25 Package

APPLICATION

- Chargers for Cell Phones, PDAs, MP3, Portable Media Players, DSCs, and Other Portable Devices and Appliances
- Rcc Adapter Replacements
- Linear Adapter Replacements
- Standby and Auxiliary Supplies

TYPICAL APPLICATION

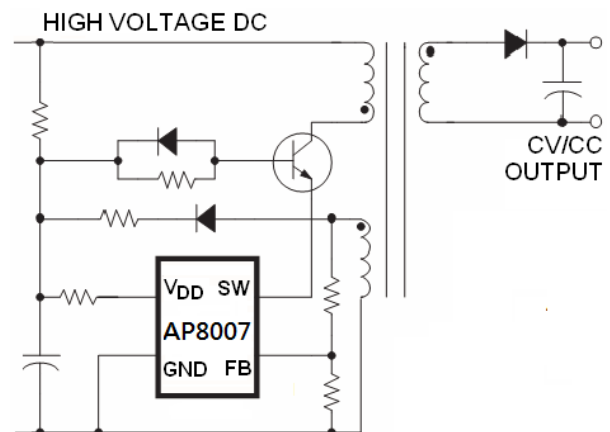

Simplified Application Circuit



PIN DESCRIPTION

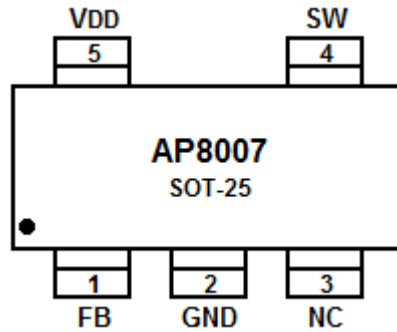

Top View

Pin #	Symbol	Function
1	FB	Feedback Pin. Connect to a resistor divider network from the auxiliary winding
2	GND	Ground
3	NC	No Connection
4	SW	Switch Driver. Connect this pin to the emitter of the power NPN transistor or source of the power MOSFET
5	V _{DD}	Power Supply



ABSOLUTE MAXIMUM RATINGS

V _{DD} to GND	-0.3V~ + 23.5V
Maximum Continuous V _{DD} Current	20mA
FB to GND	-0.3V~+6V
SW to GND	-0.3V ~ + 23.5 V
Continuous SW Current	Internally limited (A)
Maximum Power Dissipation	0.53W
θ_{JA} , Junction to Ambient Thermal Resistance	190°C/W
Operating Junction Temperature	-40°C~ + 150°C
Storage Temperature	-55°C~ + 150°C
Lead Temperature (Soldering, 10sec)	300°C

Stresses above may cause permanent damage to the device. These are stress ratings only and functional operation of the device at these or any other conditions beyond those indicated in the Electrical Characteristics are not implied. Exposure to absolute maximum rating conditions for extended periods may affect device reliability.



ELECTRICAL CHARACTERISTICS

$V_{DD}=15V$, $V_{OUT}=5V$, $LP=2mH$, $NP=130$, $NS=10$, $NA=32$, $T_A=25^{\circ}C$, unless otherwise specified.

Parameter	Symbol	Conditions	Min.	Typ.	Max.	Unit
Supply						
V _{DD} Turn-On Voltage	V _{DDON}	V _{DD} Rising	18.5	19.5	20.5	V
V _{DD} Turn-Off Voltage	V _{DDOFF}	V _{DD} Falling	6.5	7.5	8.5	V
Static Current	I _{DD}	After Turn-On, V _{DD} =15V	-	1	2	mA
Start Up Current	I _{DDST}	Before Turn-On, V _{DD} =18V	10	18	30	μA
Soft Start Time	T _{SS}		-	5	-	ms
Oscillator						
Maximum Frequency	f _{SWCLAMP}		40	50	60	kHz
Maximum Duty Cycle	D _{MAX}	I _{SW} =10mA	83	87.5	92	%
Feedback						
Effective FB Feedback Voltage	V _{FB}	FB in Regulation	3.4	3.45	3.5	V
FB Leakage Current	-		-	-	100	nA
Output Cable Drop Compensation	CABLE _{COMP}		4.5	6	-	%
Current Limit						
SW Current Limit	I _{LIM}		-	370	-	mA
Leading Edge Blanking Time	-		200	250	-	ns
SW Driver						
Switch On-Resistance	R _{ON}	I _{SW} =50mA	-	3	4	Ω
SW Off Leakage Current	-	Switch in off-state, V _{SW} =22V	-	1	10	μA
Protection						
V _{DD} OVP Trigger Voltage	V _{DDOVP}		21.5	22.5	23.5	V
FB OVP Trigger Voltage	FB _{OVP}		-	4.85	-	V
Thermal Shutdown Temperature	-		-	150	-	°C
Thermal Hysteresis	-		-	10	-	°C



BLOCK DIAGRAM

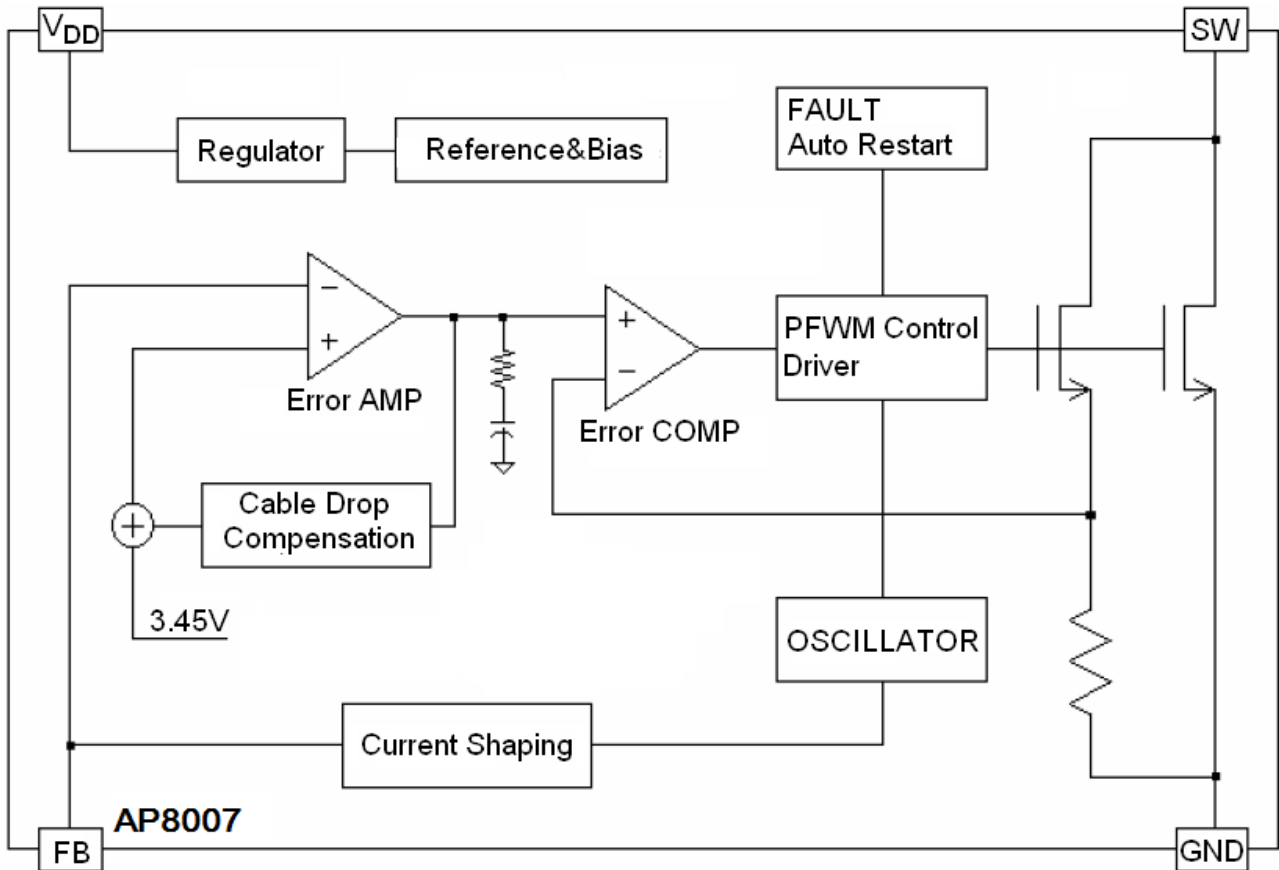



DETAILED INFORMATION

As shown in Block Diagram, to regulate the output voltage in CV (constant voltage) mode, the AP8007 compares the feedback voltage at FB pin to the internal reference and generates an error signal. The error signal, compensated with the internal compensation network, modulates the external NPN transistor peak current with current mode PFWM (Pulse Frequency and Width Modulation) control. To regulate the output current in CC (constant current) mode, the oscillator frequency is modulated by the output voltage. SW is a driver output that drives the emitter of an external high voltage NPN transistor. This base-emitter-drive method makes the drive circuit the most efficient.

Fast Startup

V_{DD} is the power supply terminal for the IC. During startup, the IC typically draws 20 μ A supply current. The bleed resistor from the rectified high voltage DC rail supplies current to V_{DD} until it exceeds the V_{DDON} threshold of 19.5V. At this point, the IC enters normal operation when switching begins and the output voltage begins to rise. The V_{DD} bypass capacitor must supply the IC and the NPN base drive until the output voltage builds up enough to provide power from the auxiliary winding to sustain the V_{DD} . The V_{DDOFF} threshold is 7.5V, and therefore, the voltage on the V_{DD} capacitor must not drop more than 7.5V while the output is charging up.

Constant Voltage (CV) Mode Operation

In constant voltage operation, the AP8007 captures the auxiliary flyback signal at FB pin through a resistor divider network. The signal at FB pin is amplified against the internal reference voltage, and the secondary side output voltage is extracted. When the secondary output voltage is above regulation, the error amplifier output voltage decreases to reduce the switch current. While the secondary output voltage is below regulation, the error amplifier output voltage increases to ramp up the switch current to bring the secondary output back to regulation. The output regulation voltage is determined by the following equation:

$$V_{OUTCV} = V_{FB} \times \left(1 + \frac{R2}{R1}\right) \times \frac{N_S}{N_A} - V_F$$

Where V_{FB} is the internal reference voltage, R1 and R2 are bottom and top feedback resistor, N_S and N_A are numbers of transformer secondary and auxiliary turns, and V_F is the rectifier diode forward drop voltage at approximately 0.1A bias.



Standby (No Load) Mode

In no load standby mode, the AP8007 oscillator frequency is further reduced to a minimum frequency while the current pulse is reduced to a minimum level to minimize standby power. The actual minimum switching frequency is programmable with an output preload resistor.

Loop Compensation

The AP8007 integrates loop compensation circuitry for simplified application design, optimized transient response, and minimal external components.

Output Cable Resistance Compensation

The AP8007 provides output cable voltage drop compensation during constant voltage regulation, monotonically adding an output voltage correction up to predetermined percentage at full load.

Constant Current (CC) Mode Operation

When the secondary output current reaches a level set by the internal current limiting circuit, the AP8007 enters current limit condition and causes the secondary output voltage to drop. As the output voltage decreases, so does the flyback voltage in a proportional manner. An internal current shaping circuitry adjusts the switching frequency based on the flyback voltage so that the transferred power remains proportional to the output voltage, resulting in a constant secondary side output current profile. The energy transferred to the output during each switching cycle is $\frac{1}{2}(L_P \times I_P^2) \times \eta$, where L_P is the transformer primary inductance, I_P is the primary peak current, and η is the conversion efficiency. From this formula, the constant output current can be derived:

$$I_{OUTCC} = \frac{1}{2} L_P \times I_P^2 \times \frac{F_{SW}}{V_{OUTCV}} \times \eta$$

Where F_{SW} is the switching frequency and V_{OUTCV} is the nominal secondary output voltage. The constant current operation typically extends down to lower than 40% of nominal output voltage regulation.

Primary Inductance Compensation

The AP8007 integrates a built-in primary inductance compensation circuit to maintain constant current regulation despite variations in transformer manufacturing. The compensated range is $\pm 7\%$.



Primary Inductor Current Limit Compensation

The AP8007 integrates a primary inductor peak current limit compensation circuit to achieve constant input power over line and load ranges.

Output Short Circuit Protection

When the secondary side output is short circuited, the AP8007 enters hiccup mode operation. In this condition, the V_{DD} voltage drops below the V_{DDOFF} threshold and the auxiliary supply voltage collapses. This turns off the AP8007 and causes it to restart. This hiccup behavior continues until the short circuit is removed.

Output Over-Voltage Protection

The AP8007 includes output over-voltage protection circuitry, which shuts down the IC when the output voltage is 40% above the normal regulation voltage for 4 consecutive switching cycles. The AP8007 enters hiccup mode when an output over voltage fault is detected.

Over Temperature Shutdown

The thermal shutdown circuitry detects the AP8007 die temperature. The typical over temperature threshold is 150°C with 10°C hysteresis. When the die temperature rises above this threshold the AP8007 is disabled until the die temperature falls by 10°C, at which point the AP8007 is re-enabled.



Application Information

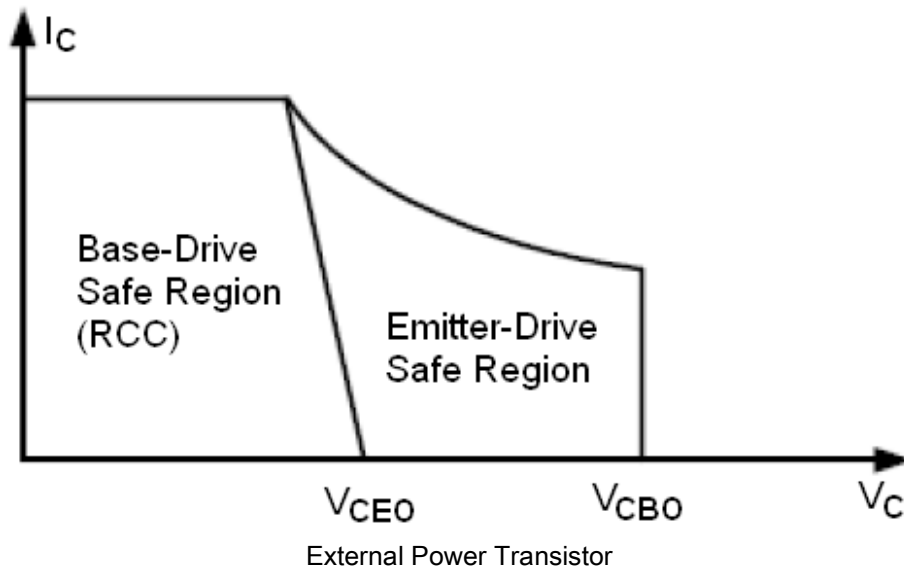

Fig. 1, NPN Reverse Bias Safe Operation Area, the AP8007 allows a low-cost high voltage power NPN transistor such as '13003 or '13002 to be used safely in flyback configuration. The required collector voltage rating for $V_{AC} = 265V$ with full output load is at least 600V to 700V. As seen from Fig 1, NPN Reverse Bias Safe Operation Area, the breakdown voltage of an NPN is significantly improved when it is driven at its emitter. Thus, the AP8007+'13002 or '13003 combination meets the necessary breakdown safety requirement. Table 1 lists the breakdown voltage of some transistors appropriate for use with the AP8007.

The power dissipated in the NPN transistor is equal to the collector current times the collector-emitter voltage. As a result, the transistor must always be in saturation when turned on to prevent excessive power dissipation. Select an NPN transistor with sufficiently high current gain ($h_{FEMIN} > 8$) and a base drive resistor low enough to ensure that the transistor easily saturates.

DEVICE	V_{CBO}	V_{CEO}	I_c	h_{FEMIN}	PACKAGE
MJE13002	600V	300V	1.5A	25	TO-126
MJE13003 KSE13003	700V	400V	1.5A	25	TO-126
STX13003	700V	400V	1A	25	TO-92



Typical Application Circuit

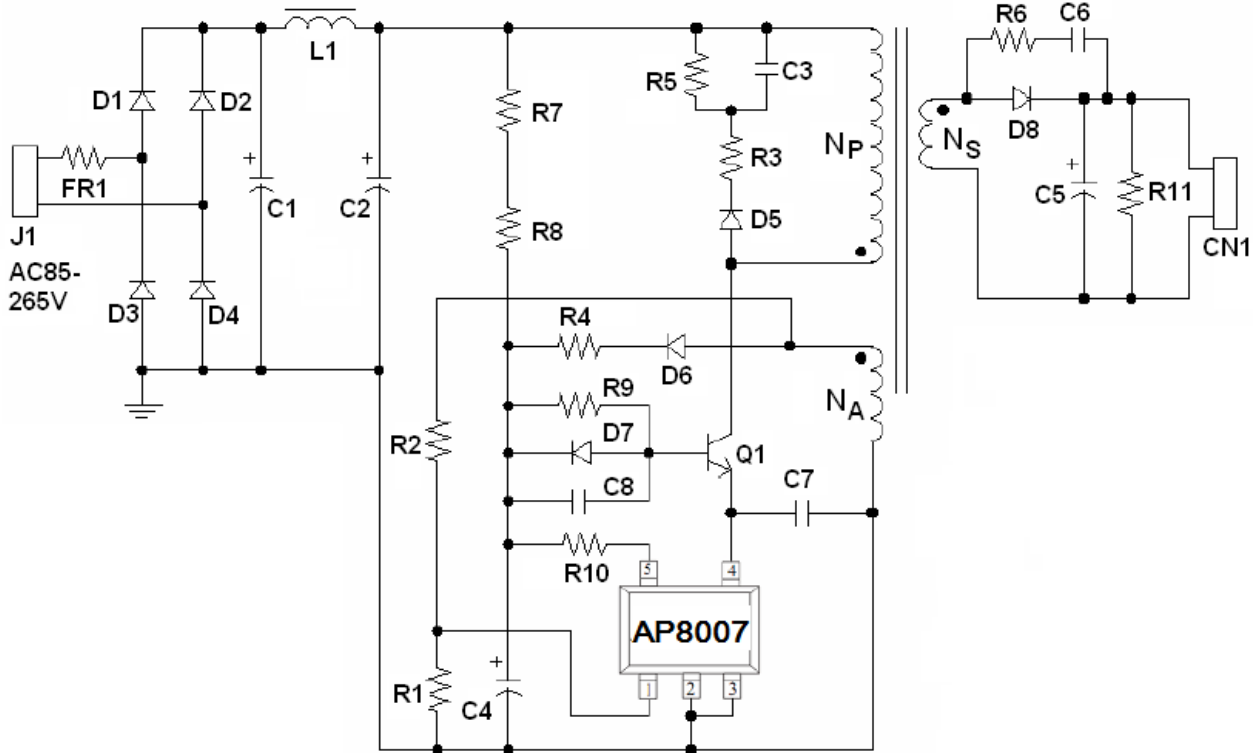

Fig. 1 5V/750mA Output for Cell Phone Charger

Table 1 Bill of Material

C1, C2	4.7 μ F/400V	Q1	13002S,TO-92
C3	4.7nF/1kV	L1	1.5mH
C4	4.7 μ F/25V	FR1	10
C5	680 μ F/10V	R1	See Table 2
C6	1nF/50V	R2	See Table 2
C7	470pF/50V	R3, R10	100
C8	680pF/50V	R4	33
D1-D4	1N4007	R5	750k
		R7, R8	1.5M
D5	FR107	R6	10
D6	HER103	R9	390
D7	1N4148	R11	1k
D8	SB240	T1	See Table 2



Design Procedure

Fig. 1, Typical Application Circuit, shows a complete, optimized constant voltage/constant current charger application. The application design procedure for using the AP8007 is simple. Based on the control IC selected, three components determine the output constant voltage and constant current settings: the transformer T1 and resistors R5 and R6. Refer to Table 2 for selection values for these three key components for different typical design cases. The Typical Application Circuit in Fig. 1 lists component values of other devices in a complete charger application.

Design Notes

1. Feedback resistors R1 and R2 must meet the $\pm 1\%$ maximum tolerance to have good V_{OUT} regulation.
2. The value of the feedback resistor can be chosen slightly different from the table according to the actual system efficiencies in different systems.
3. The value of V_{OUT} capacitor should be chosen differently to meet the V_{OUT} ripple for different systems.
4. C8 must be added to guarantee good CC accuracy.

Table 2 Component Selection

Part Number	OUTPUT		TRANSFORMER				RESISTOR NETWORK	
	$V_o(V)$	$I_o(mA)$	NP	NA	NS	LP $\pm 7\%$ (mH)	R1 $\pm 1\%$ (k Ω)	R2 $\pm 1\%$ (k Ω)
AP8007	5.0	750	130	10.	32	2.3	9.06	33

PCB Layout Consideration

Good PCB layout is critical to have optimal performance. Decoupling capacitor (C4) and feedback resistor (R1/R2) should be placed close to V_{DD} and FB pins respectively. There are two main power path loops. One is formed by C1/C2, primary winding, NPN transistor and the AP8007. The other is the secondary winding, rectifier D8 and output capacitors (C5). Keep these loop areas as small as possible. Connect high current ground returns, the input capacitor ground lead, and the AP8007 GND pin to a single point (star ground configuration).



PACKAGE INFORMATION

Dimension in SOT-25 (Unit: mm)

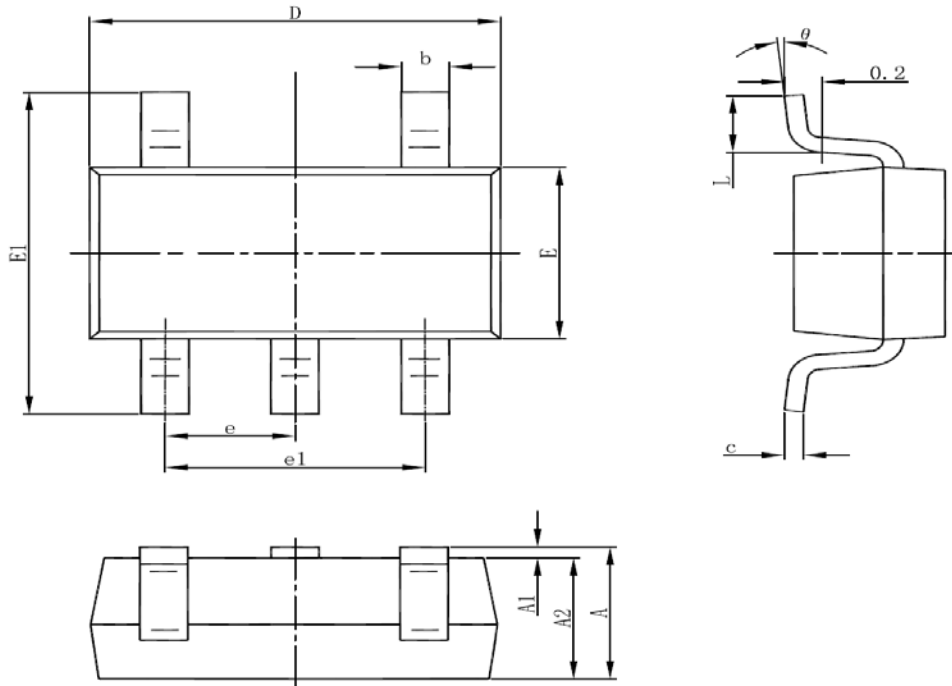

Symbol	Min	Max
A	1.050	1.250
A1	0.000	0.100
A2	1.050	1.150
b	0.300	0.500
c	0.100	0.200
D	2.820	3.020
E	1.500	1.700
E1	2.650	2.950
e	0.950(BSC)	
e1	1.800	2.000
L	0.300	0.600
θ	0°	8°



IMPORTANT NOTICE

AiT Semiconductor Inc. (AiT) reserves the right to make changes to any its product, specifications, to discontinue any integrated circuit product or service without notice, and advises its customers to obtain the latest version of relevant information to verify, before placing orders, that the information being relied on is current.

AiT Semiconductor Inc.'s integrated circuit products are not designed, intended, authorized, or warranted to be suitable for use in life support applications, devices or systems or other critical applications. Use of AiT products in such applications is understood to be fully at the risk of the customer. As used herein may involve potential risks of death, personal injury, or severe property, or environmental damage. In order to minimize risks associated with the customer's applications, the customer should provide adequate design and operating safeguards.

AiT Semiconductor Inc. assumes to no liability to customer product design or application support. AiT warrants the performance of its products of the specifications applicable at the time of sale.