



DESCRIPTION

AP8022A is a high performance offline PSR power switch for low power AC/DC charger and adapter applications. It operates in primary-side sensing and regulation. Consequently, opto-coupler and A431 could be eliminated. Proprietary Constant Voltage (CV) and Constant Current (CC) control is integrated as shown in the figure below.

Typical

ICC/CV Curve

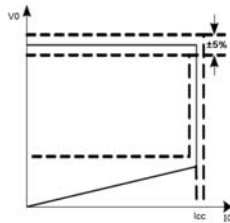

In CC control, the current and output power setting can be adjusted externally by the sense resistor R_s at CS pin. In CV control, multi-mode operations are utilized to achieve high performance and high efficiency.

In addition, good load regulation is achieved by the built-in cable drop compensation. Device operates in PFM in CC mode at large load condition and it operates in PWM with frequency reduction at light/medium load.

The AP8022A consumes very low operation current. It achieves less than 75mW standby power to meet strict s standby power standard.

AP8022A offers comprehensive protection coverage with auto-recovery feature including Cycle-by-Cycle current limiting, V_{DD} over voltage protection, feedback loop open protection, built-in leading-edge blanking, V_{DD} under voltage lockout (UVLO), OTP etc.

The AP8022A is available in DIP7 packages.

ORDERING INFORMATION

Package Type	Part Number	
DIP7 SPQ: 50pcs/Tube	P7	AP8022AP7U
		AP8022AP7VU
Note	V: Halogen free Package U: Tube Package	
AiT provides all RoHS products		

FEATURES

- Primary side Sensing and Regulation Without A431 and Opto-Coupler
- High Precision Constant Voltage and Current Regulation at Universal AC Input
- Multi-mode PWM/PFM Operation for Efficiency Improving
- Integrated 2A 1000V MOSFET
- Good Dynamic Response with Synchronous Rectifier Application
- Programmable CV and CC regulation
- Built-in primary winding inductance Compensation
- Programmable Cable Drop Compensation
- No need for Control Loop Compensation
- Audio Noise free Operation
- Built-in leading-edge blanking (LEB)
- Ultra-low start-up current and low Operating Current
- Comprehensive Protection Coverage with Auto-Recovery
 - . On-Chip OTP
 - . V_{DD} Over Voltage Protection
 - . V_{DD} under Voltage Lockout with Hysteresis (UVLO)
 - . Cycle-by-Cycle Current Limiting
 - . Feedback Loop Open Protection
 - . Output Short Circuit Protection

APPLICATION

Low Power AC/DC offline SMPS for

- Industrial instruments: single / three-phase meters
- Outdoor monitoring / protection equipment
- AC / DC with high input voltage

TYPICAL APPLICATION

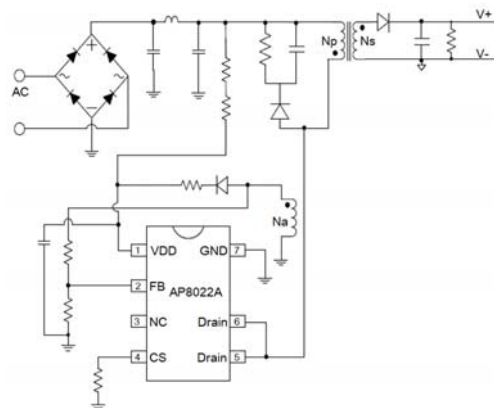



PIN DESCRIPTION

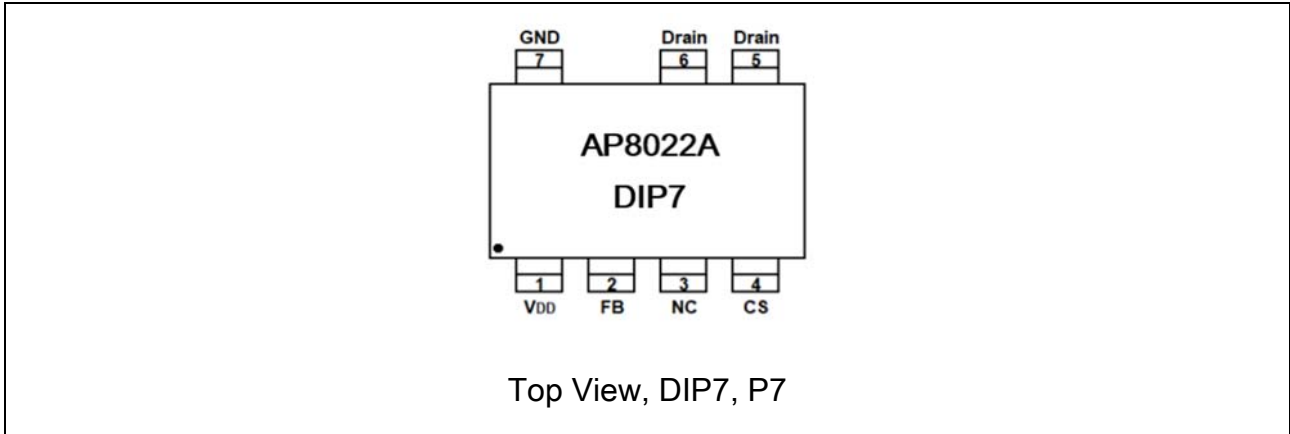

Pin #	Symbol	Function
DIP7		
1	V _{DD}	Power Supply
2	FB	The voltage feedback from auxiliary winding. Connected to resistor divider from auxiliary winding reflecting output voltage.
3	NC	NC
4	CS	Power MOSFET source
5	Drain	Drain of internal power MOSFET
6	Drain	Drain of internal power MOSFET
7	GND	Ground



ABSOLUTE MAXIMUM RATINGS

V _{DD} , Voltage	-0.3V ~ 28.5V
FB Input Voltage	-0.3V ~ 7.0V
CS Input Voltage	-0.3V ~ 7.0V
T _J , Min/Max Operating Junction Temperature	-40°C ~ 150°C
T _A , Operating Ambient Temperature	40°C ~ 125°C
Lead Temperature (Soldering, 10secs)	260°C, 10s

Stress beyond above listed "Absolute Maximum Ratings" may lead permanent damage to the device. These are stress ratings only and operations of the device at these or any other conditions beyond those indicated in the operational sections of the specifications are not implied. Exposure to absolute maximum rating conditions for extended periods may affect device reliability

RECOMMENDED OPERATING CONDITIONS

Parameter	min	Typ	Max	Unit
V _{DD} Voltage	-	-	27	V
Ambient Operating Temperature	-40	-	85	°C
Maximum Switching Frequency	-	110	-	kHz



ELECTRICAL CHARACTERISTICS

T_A = 25°C, V_{DD}=15V, if not otherwise noted

Parameter	Symbol	Conditions	Min	Typ	Max	Unit
Supply Voltage (V_{DD}) Section						
Start Up Current V _{DD} =UVLO_FF- 1V	I _{start}		0	0.5	1	uA
Static Current	I _{vdd}		0.568	-	0.852	mA
V _{DD} under voltage lockout exit	UVLO (off)		14.5	16.0	19.5	V
V _{DD} Under Voltage Lockout Enter	UVLO (on)		6.5	7	7.5	V
V _{DD} Over Voltage Protection	V _{DD-OVP}		27	28	29	V
	V _{DD}		-	-	27	V
Current Sense Input Section						
LEB time	TLEB		-	300	-	ns
Minimum Over Current Threshold	V _{th-ocp, min}		485	500	515	mV
Maximum Over Current Threshold	V _{th-ocp, max}		-	590	-	mV
CS minimum threshold	V _{cs min}		135	-	-	mV
FB Input Section						
Reference Voltage for Feedback threshold	V _{ref-FB}		2.475	2.5	2.525	V
Minimum Toff	T _{pause-min}		-	2.0	-	us
Minimum Frequency	F-min		270	305	340	Hz
Maximum Frequency	F-max		110	-	-	KHz
Maximum Cable Compensation Current	I _{comp-cable}		40	45	50	uA
CC Mode Shut Down Threshold	V _{th-cc shutdown}		-	1.55	-	V
CC Mode Shut Down Debounce	T _{D-cc shutdown}		1024	-	2048	Cycle
Output Over Voltage Protection						
Output Over voltage threshold	V-ovp		3.15	3.3	3.45	V
MOSFET Section						
MOSFET Drain-Source Breakdown Voltage	B _{vds}		1000	-	-	V
Static Drain to Source on Resistance	R _{DS(on)}		-	6	-	Ω



TYPICAL PERFORMANCE CHARACTERISTICS

Fig1. $I_{VDD_Startup}$

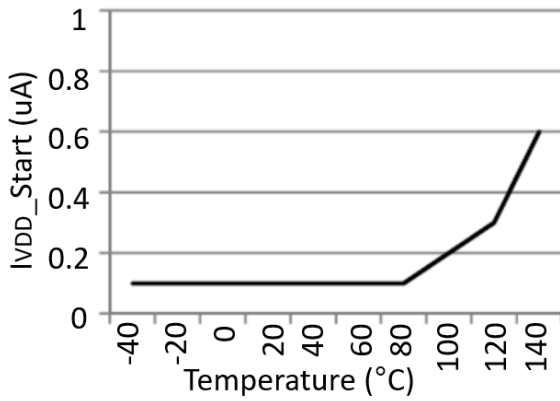

Fig2. UVLO_ON

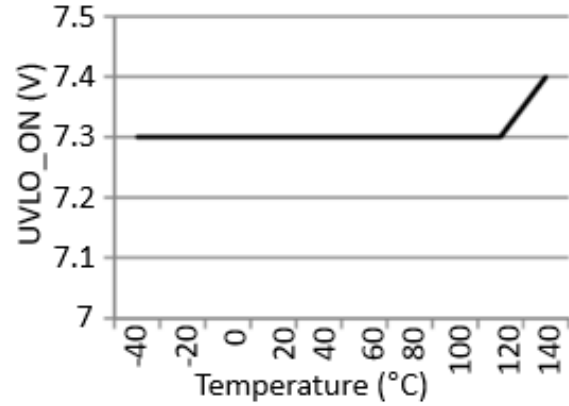

Fig3. V_{st} vs. Temperature

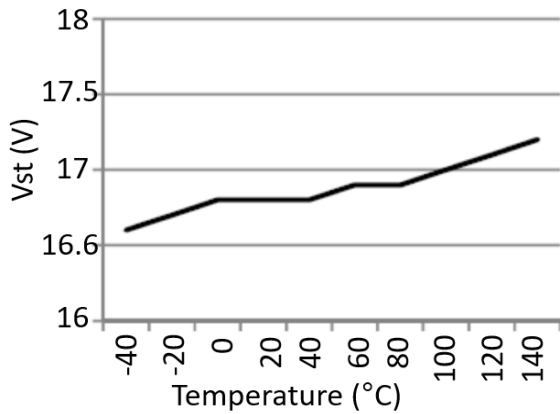

Fig4. V_{ocp} vs. Temperature

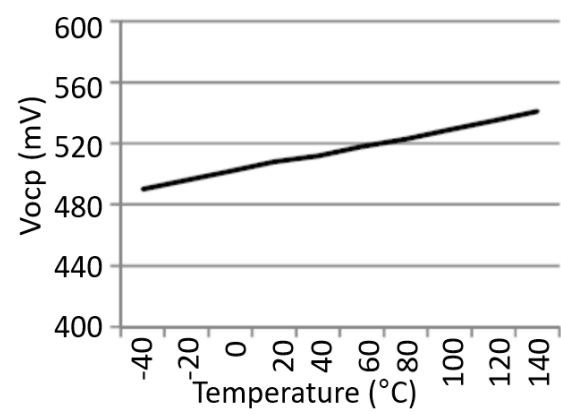

Fig5. I_{cable}

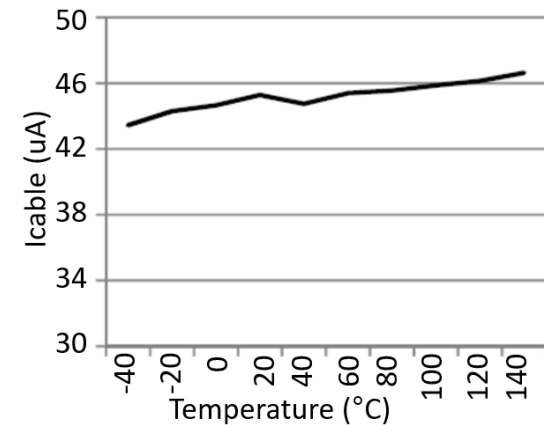
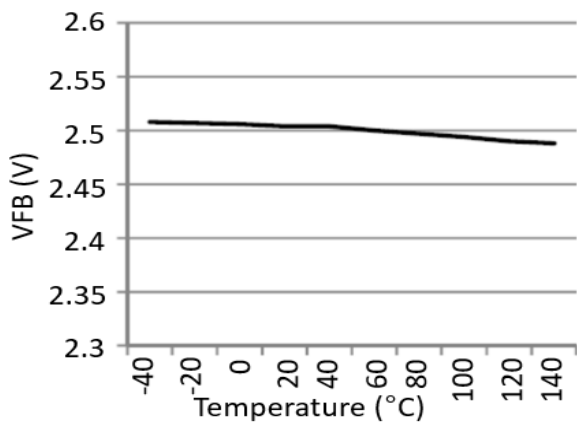
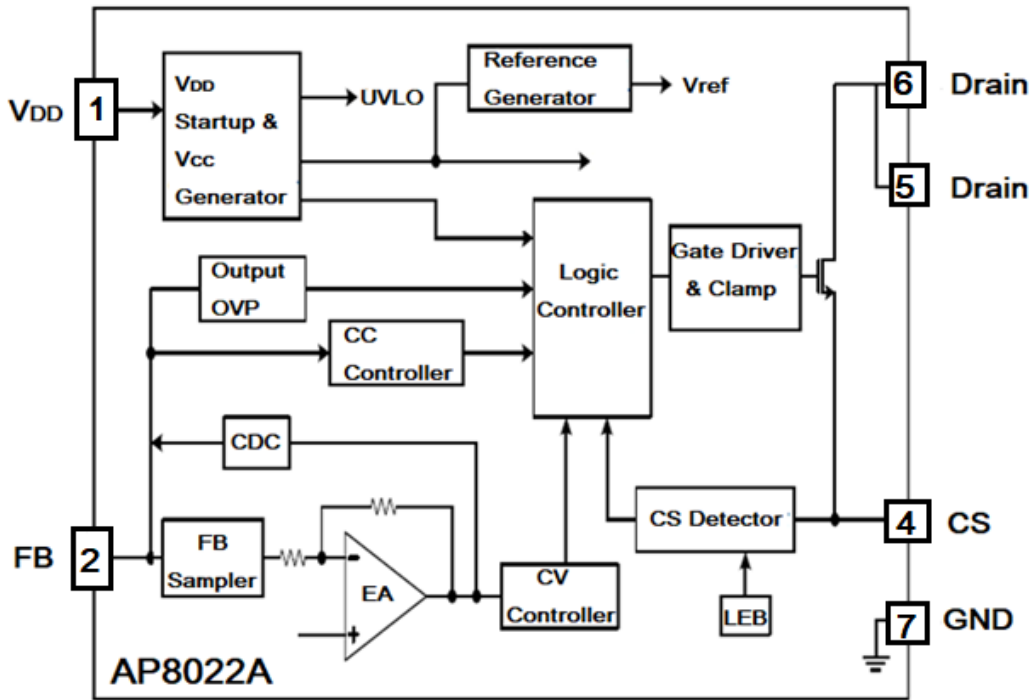

Fig6. V_{FB}





BLOCK DIAGRAM





DETAILED INFORMATION

AP8022A is a cost effective PSR power switch optimized for off-line low power AC/DC applications including battery chargers. It operates in primary side sensing and regulation, thus opto-coupler and A431 is not required. Proprietary built-in CV and CC control can achieve high precision CC/CV control meeting most charger application requirements.

Startup Current and Start up Control

Startup current of AP8022A is designed to be very low so that V_{DD} could be charged up above UVLO threshold level and device starts up quickly.

A large value startup resistor can therefore be used to minimize the power loss yet achieve a reliable startup in application.

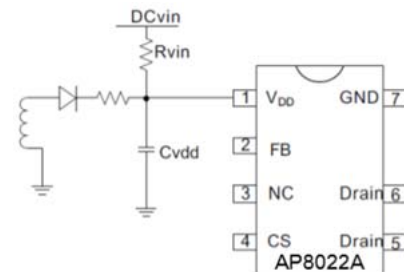

AP8022A Start Up

Operating Current

The operating current of AP8012A is as low as 650uA (typical). Good efficiency and less than 75mW standby power is achieved with the low operating current.

Adjustable CC Point and Output Power

In AP8022A, CC point and maximum value the output power can be adjusted externally, and the external current detection resistor R_{CS} (CS pin is described in the typical application diagram).

The larger R_{CS} , the smaller CC point, the smaller output power, and vice versa are shown as right

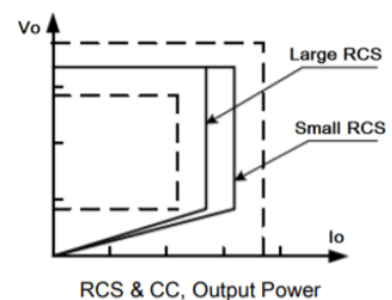



Switching Frequency

The switching frequency of AP8022A is adaptive to the output load.

For flyback operation in DCM, the maximum the output power is given by the following formula:

$$P_{O_{MAX}} = \frac{1}{2} \times L_p \times F_{sw} \times I_{peak}^2$$

among:

$P_{O_{MAX}}$ represents the maximum output power

L_p Indicates the primary side inductance of the inductance

F_{sw} Indicates the switching frequency of the system

I_{peak} Represents the peak current of the primary side

Through the above formula, it can be concluded that the maximum output power is caused by the primary inductance, and the switching frequency is caused by the internal locking of the system.

The specific formula is as follows:

$$F_{sw} = \frac{1}{2 \times T}$$

Therefore, the sum of the products is fixed, the maximum output power and the constant current of CC mode will not change, and the change of primary winding inductance is as high as $\pm 7\%$, and the change of primary winding inductance can be compensated.

Constant Current Function

AP8022A detects the peak current of the inductor one by one. The CS terminal is connected to the input terminal of the internal peak current comparator. Compared with the internal threshold voltage, when the external voltage of CS reaches the internal detection threshold, the power tube turns off.

The expression of peak current of inductance at full load is as follows:

$$I_p(\text{mA}) = \frac{500}{R_{cs}}$$

The output of CS comparator also includes edge blanking time, The calculation formula of output current is:

$$I_{cc}(\text{mA}) = \frac{5N}{4} \times \frac{500}{R_{cs}}$$

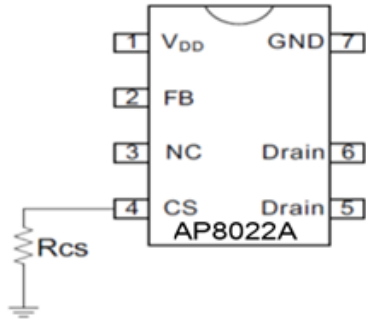

CS Sampling Diagram

among:

I_{CC} is the current at the system output.

N is the turn ration of the primary stag of the transformer

R_{CS} is the resistance between chip CS pin and GND.

Constant Voltage Control

The FB of AP8022A detects the feedback voltage of the auxiliary winding through the partial voltage of resistance R2 and R1, and the difference between the FB voltage and the reference voltage controls the frequency of the switch signal through the amplification of the error amplifier. In order to improve the accuracy of the output voltage, the leakage induction of the transformer is reduced as much as possible. The output voltage can be obtained by the following formula:

$$V_{OUT} = 2.5 \times (1 + R2 / R1) \times (N_s / N_a) - V_f$$

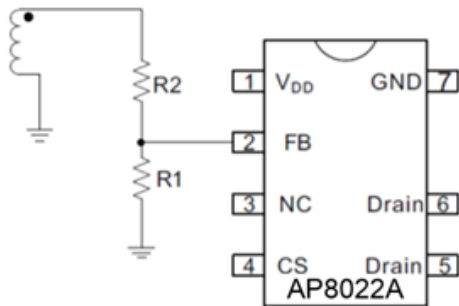

Feedback Adjustment Diagram

among :

$R1$ and $R2$ are pull-up and pull-down resistances of auxiliary winding

N_s and N_a is the number of turns of the secondary and auxiliary windings of the transformer.

V_f Table output rectifier diode voltage drop.

Current Detection and Leading Edge Blanking

AP8022A provides cycle by cycle current limitation, and the power tube current is detected by resistance sampling connected to CS pin. When the power switch is on, there will be an opening spike on the sampling resistance. In order to avoid the mis-operation caused by the opening spike, a 300ns leading edge blanking time is set on the CS pin, so there is no RC filter circuit outside the CS pin.



Output Line Voltage Compensation

In the constant voltage mode, the conventional chip adjusts the feedback voltage by changing the conduction Time of the power tube, which does not include the voltage drop on the wire. This leads to different output voltages due to the use of wires of different specifications and lengths.

The AP8022A has a built-in line voltage drop compensation circuit for better load regulation. AP8022A has the function of line loss compensation, which can compensate the voltage drop of output voltage on the wire.

Through the built-in current flowing into the resistance voltage divider, a compensation voltage is generated at the FB pin. As the converter load increase from no-load to the peak power point (the switching point between constant voltage and constant current), the voltage drop on the output wire will be compensated by increasing the reference voltage of the feedback pin. The controller determines the output load and the corresponding compensation degree according to the output of the state regulator.

The proportion of the maximum compensation can be obtained by the following formula:

$$\frac{\Delta V}{V_{out}} = \frac{I_{comp-cable} \times (R1/R2) \times 10^{-6}}{2.5} \times 100\%$$

among:

ΔV Is the compensation volage.

V_{out} is the output voltage.

R2 and R1 are the pull-up resistance of

FB I_{comp} is the compensation current.

CC Mode Shutdown Function

In AP8022A, when the chip is in CC mode, to prevent the chip feeds back to the FB pin of the chip of the auxiliary winding though the sampling output voltage. When the FB voltage is lower than 1.55V, and after 1024 and 2048 cycles, the chip is locked, and the system needs to be powered up again to resume work .

Optimize Dynamic Response

AP8022A optimizes the design of dynamic response performance to meet the needs of the adapter.

No Abnormal Sound Work

Under the constant voltage mode, the working frequency of AP8022A changes with the change of load, so that it has no abnormal sound during the whole working process form no-load to full load.

Protection Control

AP8022A integrates protection functions, including V_{DD} over-voltage and under voltage protections, including V_{DD} over-voltage and under voltage protection, FB over voltage and under voltage protection, FB over-voltage and under voltage protection, output short circuit protection, output short circuit protection, output short circuit protection, OTP protection, OTP protection and all pin suspension and all pin suspension protection.



PACKAGE INFORMATION

Dimension in DIP7 (Unit: mm)

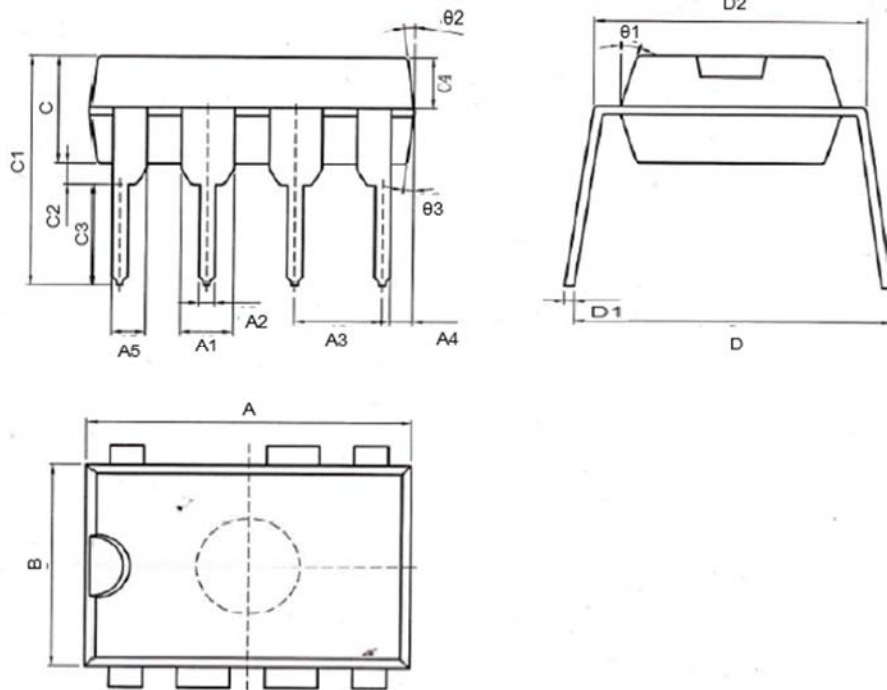

Symbol	Millimeters	
	Min	Max
A	9.00	9.20
A1	1.474	1.574
A2	0.41	0.51
A3	2.44	2.64
A4	0.51 TYP	
A5	0.99 TYP	
B	6.10	6.30
C	3.20	3.40
C1	7.10	7.30
C2	0.50 TYP	
C3	3.20	3.40
C4	1.47	1.57
D	8.20	8.80
D1	0.244	0.264
D2	7.62	7.87
θ1	17° TYP4	
θ2	10° TYP4	
θ3	8° TYP4	



IMPORTANT NOTICE

AiT Semiconductor Inc. (AiT) reserves the right to make changes to any its product, specifications, to discontinue any integrated circuit product or service without notice, and advises its customers to obtain the latest version of relevant information to verify, before placing orders, that the information being relied on is current.

AiT Semiconductor Inc.'s integrated circuit products are not designed, intended, authorized, or warranted to be suitable for use in life support applications, devices or systems or other critical applications. Use of AiT products in such applications is understood to be fully at the risk of the customer. As used herein may involve potential risks of death, personal injury, or severe property, or environmental damage. In order to minimize risks associated with the customer's applications, the customer should provide adequate design and operating safeguards.

AiT Semiconductor Inc. assumes to no liability to customer product design or application support. AiT warrants the performance of its products of the specifications applicable at the time of sale.