

AP8064 Datasheet

Audio Application Processor
(ARM Cortex-M3 based)

Rev 1.2

DISCLAIMER

All information and data contained in this document are without any commitment, are not to be considered as an offer for conclusion of a contract, nor shall they be construed as to create any liability. Any new issue of this document invalidates previous issues. Product availability and delivery are exclusively subject to our respective order confirmation form; the same applies to orders based on delivered development samples delivered. By this publication, Shanghai Mountain View Silicon Co., Ltd. (“MVSILICON”) does not assume responsibility for patent infringements or other rights of third parties that may result from its use.

No part of this publication may be reproduced, photocopied, stored in a retrieval system, or translated in any form or by any means, electronic, mechanical, manual, optical, or otherwise, without the prior written permission of Shanghai Mountain View Silicon Co., Ltd.

Shanghai Mountain View Silicon Co., Ltd. assumes no responsibility for any errors contained herein.

Revision History

Date	Revision	Description
2014-03-20	V0.9	Change power supply voltage value
2014-04-11	V1.0	Add the pin function table, LDO330 V-I chart and the store/reflow requirements
2016-01-18	V1.1	Revised the description of chip features
2016-03-20	V1.2	Add the Codec’s functional block

Contents

1. Overview.....	1
1.1 Features.....	1
1.2 CODEC Functional Block.....	2
2. Pin Description.....	3
2.1 Pin Description.....	3
3. Package.....	6
3.1 Package Diagram.....	6
3.2 Package Dimension Parameter.....	7
4. Electrical Specification.....	8
4.1 Absolute Maximum Ratings (Note 1).....	8
4.2 Recommended Operating Conditions.....	8
4.3 Electrical Characteristics.....	8
4.4 LDO330 driving capability.....	8
4.5 Audio Performance.....	9
5. Store and Reflow.....	12
Contact Information.....	13

Figures

Figure 1 CODEC Functional Block.....	2
Figure 2 Package Diagram (LQFP64-7x7mm / TOP View).....	6
Figure 3 LQFP64-7x7mm Package Dimension Parameter.....	7
Figure 4 LDO330 driving capability.....	8

Tables

Table 1 Pin Description.....	3
Table 2 GPIO Pin Function.....	4
Table 3 Absolute Maximum Ratings.....	8
Table 4 Recommended Operating Conditions.....	8
Table 5 Electrical Characteristics.....	8
Table 6 Audio DAC Performance	9
Table 7 DAC LINE-IN (high quality) Channel Characteristics.....	10
Table 8 LINE-IN (normal quality) Channel Characteristics.....	11

Table 9 MIC Channel Characteristics..... 11

1. Overview

As a highly integrated SoC for audio application processing, AP8064 integrates ARM Cortex-M3, OTG, SD/MMC card controller, SARADC, audio DAC, audio ADC, segment LCD display driver, RTC and IR decoder in a single chip. AP8064 supports Bluetooth stack, various audio decoders, encoders, and effects. In general AP8064 offers low power consumption, flexible and more powerful wireless audio player solution.

1.1 Features

- ARM Cortex-M3, running @ 96MHz, with 128K byte SRAM
- Embedded LDO, with 3.3V output
- OTG 2.0 full-speed controller
- SD/MMC card controller
- 12-bit SARADC
- Low power RTC with NVM to save external RTC & EEPROM
- Display driver for Segment LCD
- High speed UART with flow control
- Multiple PWM outputs
- IR (NEC) decoder
- Touch key driver
- Multiple GPIOs for various purposes
- Code encryption mechanism in SPI-flash
- Support FAT16/FAT32 file system
- Bluetooth stack including A2DP, AVRCP, HFP, SPP, OBEX etc

- Audio input and output
 - Stereo 20-bit high quality Audio DAC, SNR ≥ 95 dB
 - Stereo 16-bit high quality Sigma Delta ADC, SNR ≥ 90 dB
 - Programmable preamp gain for input from microphone and line-in
 - Programmable ALC / Noise Gate
 - Built-in headphone driver with “capless” option
 - ◆ >40 mW output power into $16\Omega / 3.3$ V
 - ◆ THD -80 dB at 20mW, SNR 90dB with 16Ω load
 - Tone generator
 - I2S digital audio input/output
 - 9 sample rates supported: 8kHz, 11.025 kHz, 12 kHz, 16 kHz, 22.05 kHz, 24 kHz, 32 kHz, 44.1 kHz, 48kHz

- Audio Algorithms
 - Decoders: MP2/MP3, WMA, FLAC(8/16/24bit), AAC/MP4/M4A, WAV(IMA-ADPCM and raw PCM), AIF, AIFC
 - Encoder: MP2/MP3, IMA-ADPCM
 - Effects:
 - ◆ Echo
 - ◆ Reverb
 - ◆ MV3D
 - ◆ MVBASS
 - ◆ Pitch shifter
 - ◆ Parametric EQ
 - ◆ Dynamic Range Compression (DRC)
 - ◆ Acoustic Echo Cancellation (AEC)
 - ◆ Programmable frequency shifter for howling prevention
 - ◆ Fast and accurate howling detection and suppression

- Serial wire debug (SWD) interface
- Firmware updatable through SD/USB drive

1.2 CODEC Functional Block

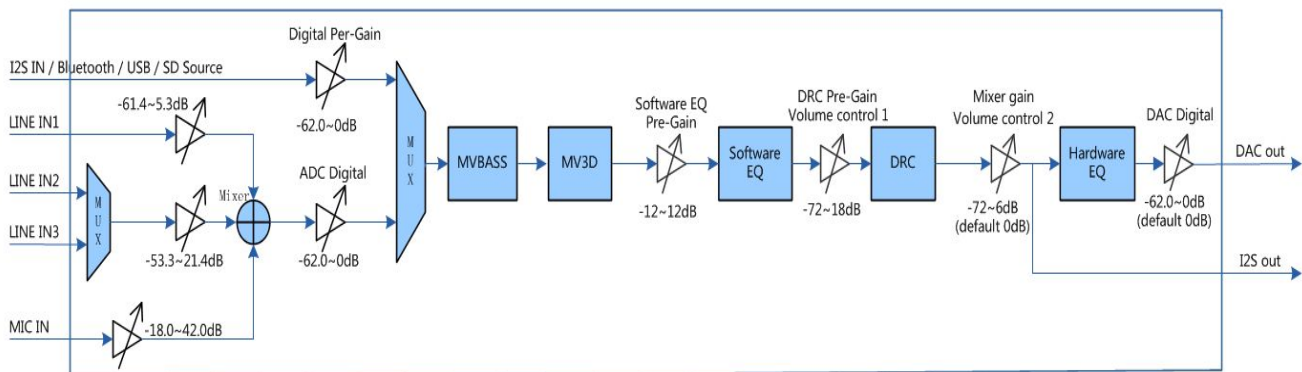

Figure 1 CODEC Functional Block

Notes.

1. Adjust the system volume either through DRC pre-gain (DRC on) or mixer gain (DRC off).
2. Direct control of DAC digital volume is NOT recommended.

2. Pin Description

AP8064 is a CMOS device. Floating level on input signals causes unstable device operation and abnormal current consumption. Pull-up or Pull-down resistors should be used appropriately for input or bidirectional pins.

Notation	Description
I	Input
O	Output
I/O	Bidirectional
PWR	Power
GND	Ground

2.1 Pin Description

Table 1 Pin Description

Pin Name	Pin #	Type	Description
Audio CODEC interface pins			
DAC_R	11	AO	audio right channel output
DAC_L	12	AO	audio left channel output
DACVMID	10	AI	Internal voltage reference
DAC_LINER	14	AI	Audio aux right in (high quality)
DAC_LINEL	15	AI	Audio aux left in (high quality)
MIC	16	AI	MIC input
MICBIAS	17	AI	MIC voltage reference
GPIO/MCU IO pins			
GPIO_A[0]	26	I/O	GPIO PORT, bank A
GPIO_A[10]	27	I/O	GPIO PORT, bank A
GPIO_A[16:12]	32:28	I/O	GPIO PORT, bank A
GPIO_A[25:17]	42:34	I/O	GPIO PORT, bank A
GPIO_B[7:2]	48:43	I/O	GPIO PORT, bank B
GPIO_B[31:20]	63:52	I/O	GPIO PORT, bank B
GPIO_C[0]	64	I/O	GPIO PORT, bank C
GPIO_C[4:1]	4:1	I/O	GPIO PORT, bank C
GPIO_C[14:11]	8:5	I/O	GPIO PORT, bank C
CLK pins			
XIN	19	I	32.768KHz Crystal oscillator input for PLL
XOUT	18	O	32.768KHz Crystal oscillator output for PLL
Power/Ground pins			
DVSS	49	GND	ground for digital
LDOIN	22	PWR	LDO power in
LDO330	21	PWR	LDO 3.3V out
LDO120	24	PWR	LDO 1.2V out
IOVDD	33,51	PWR	IO 3.3V
COREVDD	50	PWR	power for core
DCOVDD	25	PWR	PLL power

DACVDD	13	PWR	power for DAC
DACAVSS	9	GND	ground for DAC
RTCVDD	20	PWR	Power for RTC
MISC pins			
POWER_KEY	23	I	Power Key

Table 2 GPIO Pin Function

Pin Name	Other Function Assignment
GPIO_A[0]	PWM0 / UART_TX / CHARGE-LED
GPIO_A[10]	IR0 / PWC0 / PWM3 / WAKEUP
GPIO_A[12]	12M_16M_OUT0 / BUART_RTS
GPIO_A[13]	FSH_HOLD
GPIO_A[14]	FSH_SCK
GPIO_A[15]	FSH_SI
GPIO_A[16]	FSH_WP
GPIO_A[17]	FSH_SO
GPIO_A[18]	FSH_CS
GPIO_A[19]	SD1_DAT / SPIM1_MISO
GPIO_A[20]	SD1_CLK / SPIM1_CLK
GPIO_A[21]	SD1_CMD / SPIM1_MOSI
GPIO_A[22]	USB2_DP
GPIO_A[23]	USB2_DM
GPIO_A[24]	BUART_RX / USB1_DP
GPIO_A[25]	BUART_TX / USB1_DM
GPIO_B[2]	MCLK0_IN / MCLK0_OUT
GPIO_B[3]	I2S0_LRCK / PCM0_SYNC / SD2_DAT / SPIM2_MISO
GPIO_B[4]	I2S0_BCLK / PCM0_CLK / SD2_CLK / SPIM2_CLK
GPIO_B[5]	ADC0 / I2S0_DO / PCM0_DO / SD2_CMD / SPIM2_MOSI / WAKEUP
GPIO_B[6]	ADC1 / I2S0_DIN / PCM0_DIN / PWM4 / UART_RX / WAKEUP
GPIO_B[7]	ADC2 / IR1 / PWC1 / PWM5 / UART_TX / WAKEUP
GPIO_B[20]	LCD0 / PWM7 / SD3_CMD / SPIM3_MOSI / SPIS_MOSI
GPIO_B[21]	LCD1 / PWM6 / SD3_CLK / SPIM3_CLK / SPIS_CLK
GPIO_B[22]	ADC3 / LCD2 / PWM5 / SD3_DAT / SPIM3_MISO / SPIS_MISO / WAKEUP
GPIO_B[23]	ADC4 / LCD3 / PWM4 / SPIS_CS / WAKEUP
GPIO_B[24]	ADC5 / LCD4 / I2S1_LRCK / PCM1_SYNC / PWM3 / WAKEUP
GPIO_B[25]	ADC6 / LCD5 / I2S1_BCLK / PCM1_CLK / PWM2 / WAKEUP
GPIO_B[26]	LCD6 / I2S1_DO / PCM1_DO / PWM1 / TK0
GPIO_B[27]	LCD7 / I2S1_DIN / PCM1_DIN / PWM0 / TK1
GPIO_B[28]	BUART_TX / LCD8 / TK2
GPIO_B[29]	BUART_RX / LCD9 / TK3
GPIO_B[30]	32K_OUT1 / BUART_CTS / LCD10 / TK4
GPIO_B[31]	12M_16M_OUT1 / BUART_RTS / LCD11 / TK5
GPIO_C[0]	32K_OUT2 / BUART_CTS / LCD12 / TK_CMPOUT
GPIO_C[1]	12M_16M_OUT2 / BUART_RTS / LCD13 / TK6
GPIO_C[2]	IR2 / LCD14 / TK7 / WAKEUP
GPIO_C[3]	LCD15 / TK8 / UART_TX
GPIO_C[4]	LCD16 / TK9 / UART_RX
GPIO_C[11]	LINE2_L(normal quality)
GPIO_C[12]	LINE2_R(normal quality) / SWV

GPIO_C[13]	LINE1_L(normal quality) / SWCLK
GPIO_C[14]	LINE1_R(normal quality) / SWD

Notes.

3. 'TK' is drive pin for touch key function.
4. 'CHARGE-LED' is a function for indicating the charge status of battery even in power down mode.
5. All GPIOs can be used as external interrupt pins.
6. For each of the following modules, only one port group can be activated at any given time, e.g., either USB1 or USB2 can be activated, but not both at the same time.

Module	Port Groups
12M_16M clock	12M_16M_OUT0, 12M_16M_OUT1, 12M_16M_OUT2
32K clock	32K_OUT1, 32K_OUT2
IR	IR0, IR1, IR2
I2S	I2S0, I2S1
PCM	PCM0, PCM1
PWC	PWC0, PWC1
SD	SD1, SD2, SD3
SPIM	SPIM1, SPIM2, SPIM3
USB	USB1, USB2

7. For the following modules, there are two scenarios:

Scenario 1, the signal bus can be activated separately, e.g., use UART_TX or UART_RX only;

Scenario 2, only one port can be allocated to the signal bus at any given time, e.g., UART_RX can be allocated to GPIO_B[6] or GPIO_C[4].

Module	Signal Bus	Ports
UART	UART_TX	GPIO_A[0], GPIO_B[7], GPIO_C[3]
	UART_RX	GPIO_B[6], GPIO_C[4]
BUART	BUART_TX	GPIO_A[25], GPIO_B[28]
	BUART_RX	GPIO_A[24], GPIO_B[29]
	BUART_CTS	GPIO_B[30], GPIO_C[0]
	BUART_RTS	GPIO_A[12], GPIO_B[31], GPIO_C[1]

3. Package

3.1 Package Diagram

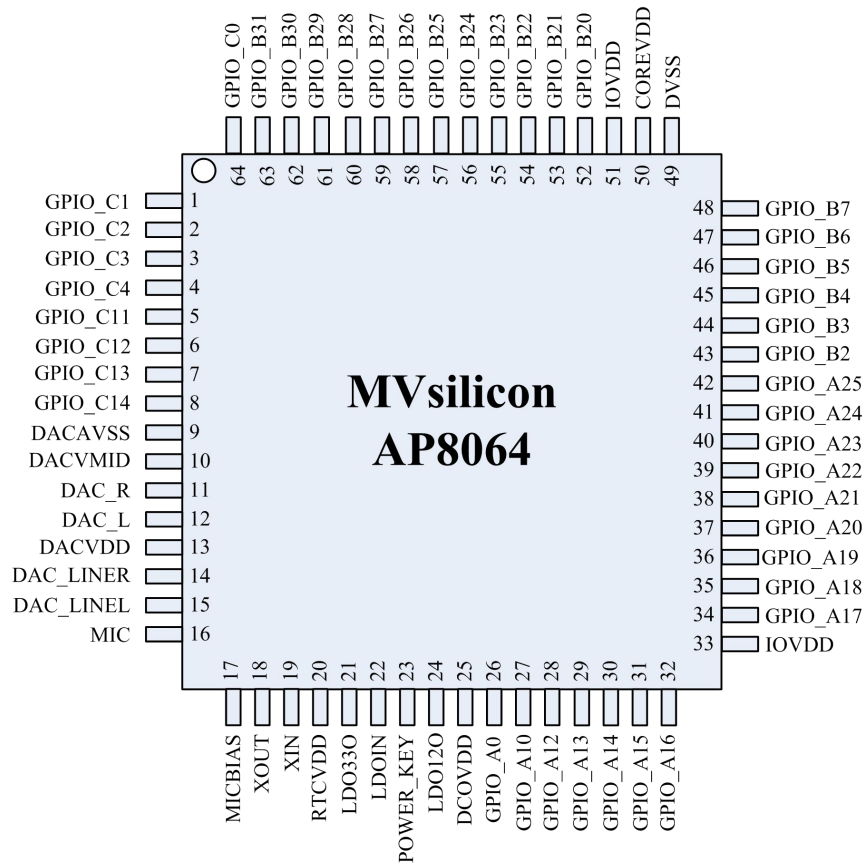

Figure 2 Package Diagram (LQFP64-7x7mm / TOP View)

3.2 Package Dimension Parameter

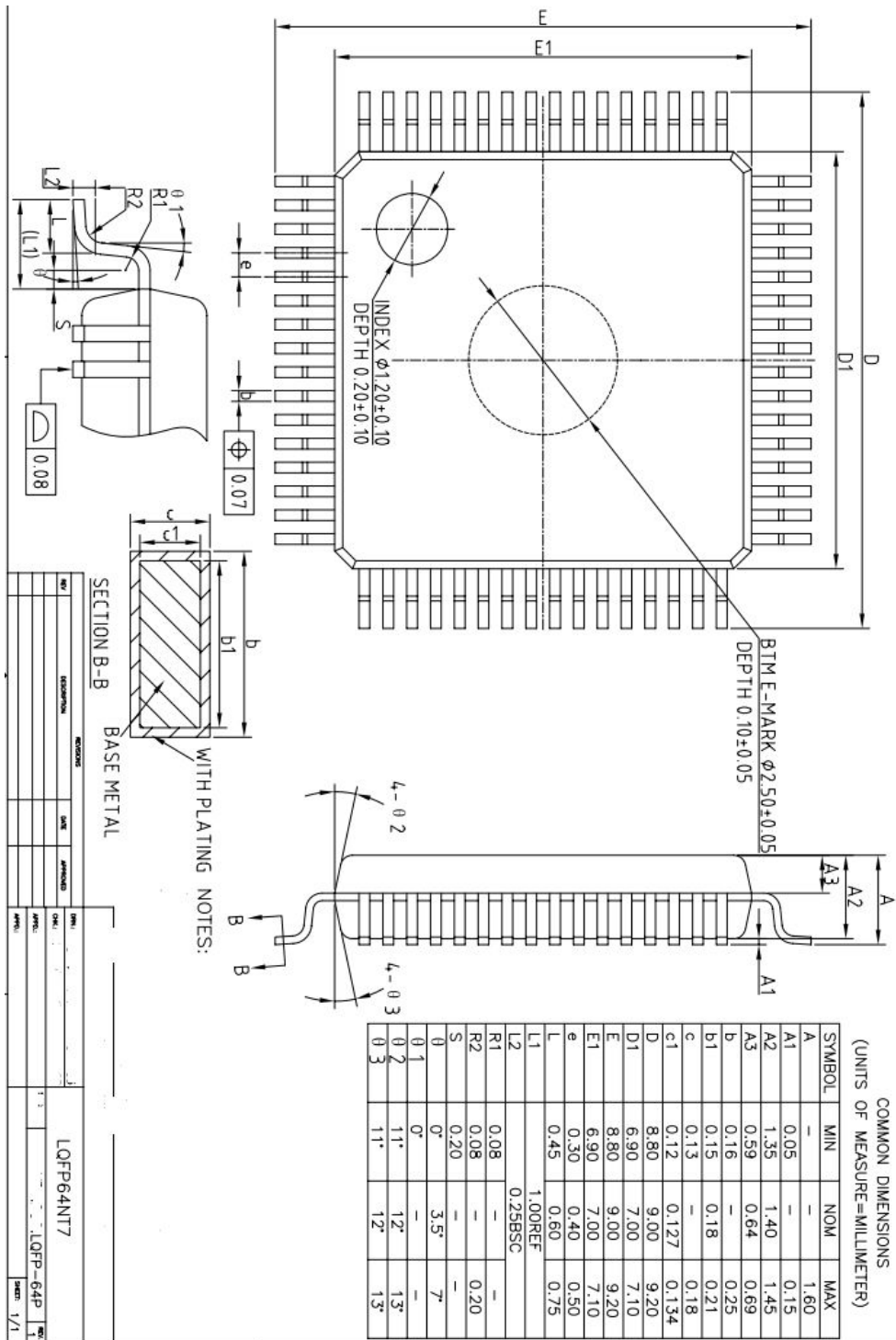

Figure 3 LQFP64-7x7mm Package Dimension Parameter

4. Electrical Specification

4.1 Absolute Maximum Ratings (Note 1)

Table 3 Absolute Maximum Ratings

Parameter	Symbol	Rating	Unit
Storage Temperature	TEMP_STG	-65 to 150	C

4.2 Recommended Operating Conditions

Table 4 Recommended Operating Conditions

Parameter	Symbol	Min	Typ	Max	Unit
Power Supply Voltage	LDOIN	3.35	5.0	5.5	V
IO Input Voltage	VIN	0		3.6	V
Operating Free Air Temperature	TEMP_OPR	-40		85	C

4.3 Electrical Characteristics

Table 5 Electrical Characteristics

Symbol	Parameter	Condition	Min	Typ	Max	Unit
VIH	Input High Voltage		1.6		3.6	V
VIL	Input Low Voltage		-0.3		1.4	V
VOH	Output high voltage	@IOH=2mA	3.0			V
VOL	Output low voltage	@IOL=2mA			0.3	V
IL	Input leakage current		-10		10	uA
P_PLAY current	Current consumption when playing	Playing mode		30		mA
RTC current	Current consumption for RTC & NVM			16		uA

4.4 LDO330 driving capability

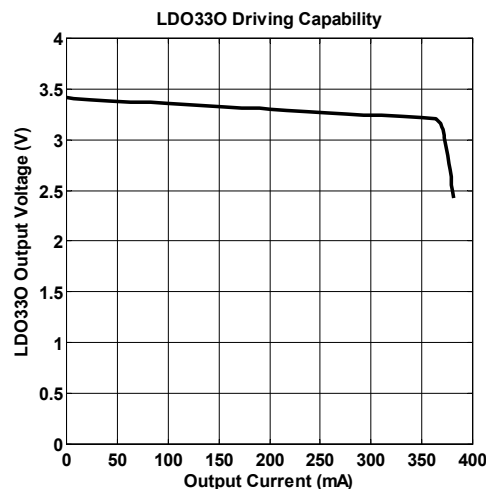

Figure 4 LDO330 driving capability

Note. Not fully tested, characterized only; 2, LDOIN=5V, T_A=25°C

4.5 Audio Performance

Table 6 Audio DAC Performance

PARAMETER	TEST CONDITIONS	MIN	TYP	MAX	UNIT
Dynamic Range	No Filter		93.6/93.6		dB
	With A-Weighted Filter		95/95		dB
Signal-to-Noise Ratio	No Filter		95.5/95.6		dB
	With A-Weighted Filter		98/98		dB
THD+N	Peak THD+N (@0dBFS)		-81/-81		dB
	0dBFS		-75/-75		dB
Frequency Response			0.06		dBV
Output Swing			0.993		Vrms
Inter-channel Gain Mismatch			0.003		dB
Volume Control Step			TBD		dB
Volume Control Range			TBD		dB
Group Delay			80		us
Inter-channel Phase Deviation			0.01		degree
Crosstalk			-99/-98		dB

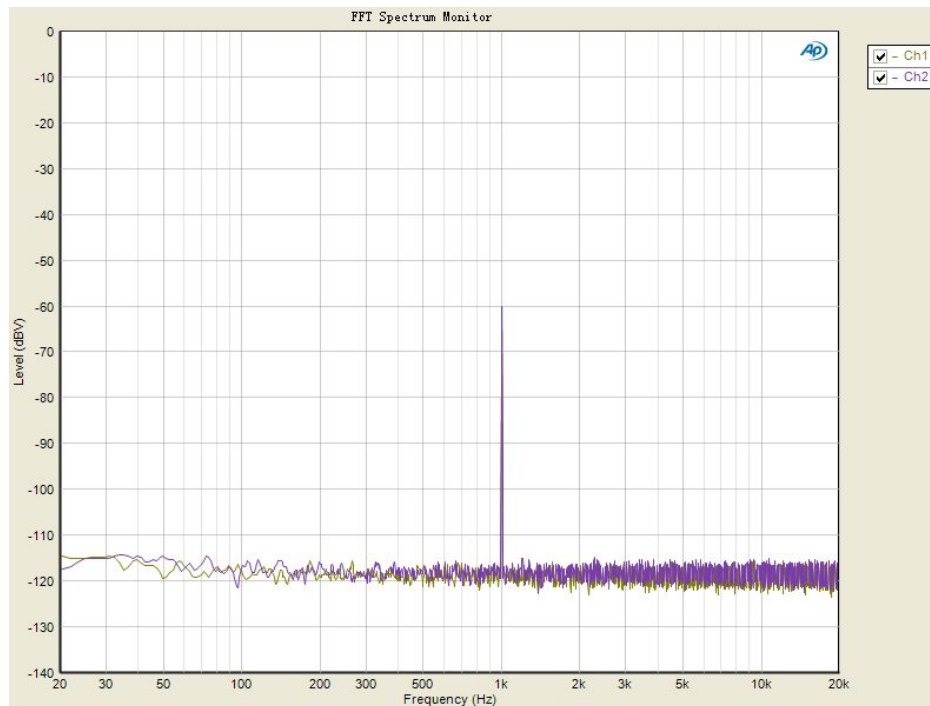

The measured output audio spectrum when the output is at -60 dBV

Table 7 DAC LINE-IN (high quality) Channel Characteristics

PARAMETER	TEST CONDITIONS	MIN	TYP	MAX	UNIT
Dynamic Range	No Filter		88/88		dB
	With A-Weighted Filter		90/90		dB
Signal-to-Noise Ratio	No Filter		88/88		dB
	With A-Weighted Filter		90/90		dB
THD+N	Peak THD+N (@-2.4dBFS)		-84/-84		dB
Volume Control Step			TBD		dB
Volume Control Range			TBD		dB
Group Delay			26		fs
Power Consumption			7.6		mW
Power Supply Rejection Ratio	1kHz, 300mVrms		55		dB

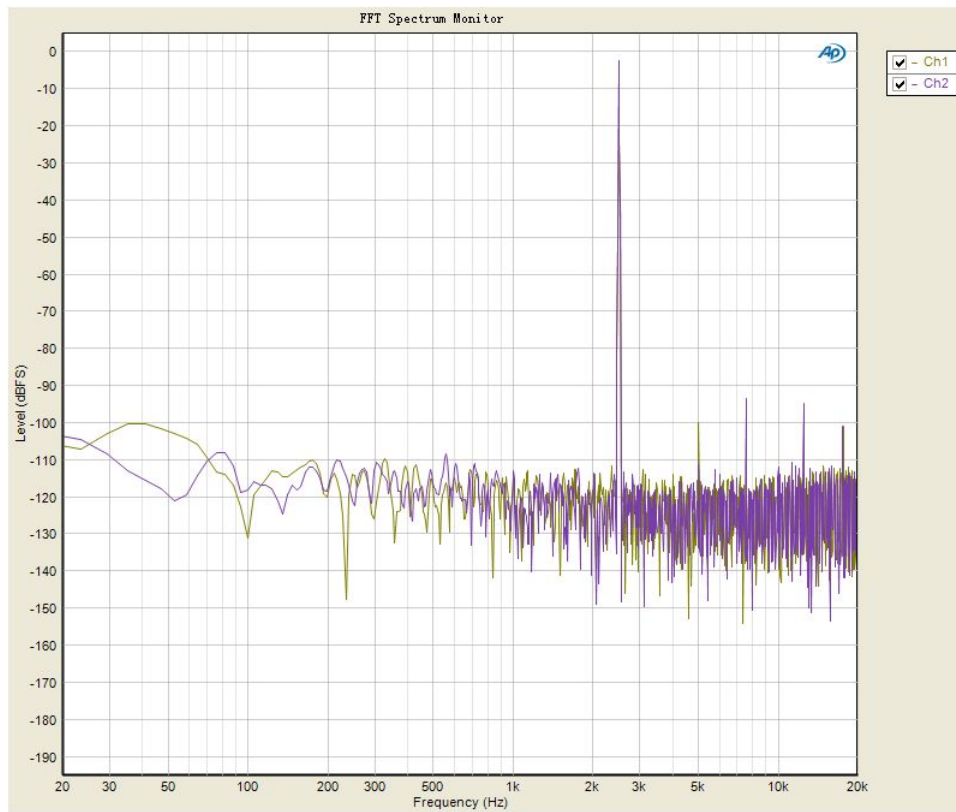

The measured audio spectrum when the analog input is at -2.6 dBV

Table 8 LINE-IN (normal quality) Channel Characteristics

PARAMETER	TEST CONDITIONS	MIN	TYP	MAX	UNIT
Dynamic Range	No Filter		86		dB
	With A-Weighted Filter				dB
Signal-to-Noise Ratio	No Filter		85		dB
	With A-Weighted Filter				dB
THD+N	Peak THD+N (@-12dBFS)		-75		dB
Group Delay			26		fs
Power Consumption			7.6		mW
Power Supply Rejection Ratio	1kHz, 300mVrms		55		dB

Table 9 MIC Channel Characteristics

PARAMETER	TEST CONDITIONS	MIN	TYP	MAX	UNIT
Dynamic Range	No Filter		87.5/87.5		dB
	With A-Weighted Filter		90/90		dB
Signal-to-Noise Ratio	No Filter		85.5/85.5		dB
	With A-Weighted Filter		88.5/88.5		dB
THD+N	Peak THD+N (@-2dBFS)		-82/-82		dB
Group Delay			26		fs
Crosstalk			TBD		dB
Power Consumption			7.6		mW
Power Supply Rejection Ratio	1kHz, 300mVrms		55		dB

Note:

1. “Absolute Maximum Ratings” are those values beyond which the safety of the device cannot be guaranteed. They are not meant to imply that the device should be operated at these limits.

5. Store and Reflow

AP8064 is a moisture sensitive component. The moisture sensitivity classification is **Class 3**.

It's important that the parts are handled under precaution and a proper manner.

The handling, baking and out-of-pack storage conditions of the moisture sensitive components are described in IPC/JEDC S-STD-033A.

The Technologies recommends utilizing the standard precautions listed below.

1. Calculated shelf life in Sealed Bag: 12 months at $<40^{\circ}\text{C}$ and $<90\%$ relative humidity(RH)
2. Peak Package Body Temperature: 250°C
3. After bag is opened, devices that will be subjected to reflow solder of other high temperature process must be:
 - a. Mounted within 168 hours of factory condition $\leq 30^{\circ}\text{C}$ / 60% RH
 - b. Stored at $<10\%$ RH if not used
4. Devices require baking, before mounting if:
 - a. Humidity indicator card is $>10\%$ when read at $23\pm 5^{\circ}\text{C}$ immediately after moisture barrier bag is opened
 - b. Items 3a or 3b is not met
5. If baking is required, please refer to J-STD-033 standard for low temperature (40°C) baking requirement in Tape/Reel form.

Contact Information

Shanghai Mountain View Silicon Co Ltd

Shanghai Headquarter:

Suite 4C, Hengyue International Building 3, 1238 Zhangjiang Road,
Shanghai, P.R. China

Zip code: 201203

Tel: 86-21-68549851/68549853/68549857/61630160

Fax: 86-21-61630162

Shenzhen Sales & Technical Support Office:

Suite 6A Olympic Plaza, Shangbao Road, Futian District,
Shenzhen, Guangdong, P.R. China

Zip code: 518034

Tel: 86-755-83522955

Fax: 86-755-83522957

Email: support@mvsilicon.com

Website: <http://www.mvsilicon.com>