

1A Adjustable & Fixed Voltage LDO Linear Regulator

Features

- I **Operating Voltage Range : +2.0V to +7.0V**
- I **Adjustable Output Voltage (AP8860-Px) or Fixed Output Voltage (AP8860-xxPx) Preset at 1.8V, 2.5V, 3.3V**
- I **Maximum Output Current : 1A**
- I **Dropout Voltage : 60mV @ 100mA**
- I **±2% Output Voltage Accuracy(special ±1% highly accurate)**
- I **Small Output Capacitor**
- I **High Ripple Rejection : 75 dB**
- I **Output Current Limit Protection (1.3A)**
- I **Short Circuit Protection (650mA)**
- I **Thermal Overload Shutdown Protection**
- I **SOT-223 and TO-252 Packages**
- I **RoHS Compliant and 100% Lead (Pb)-Free and Green (Halogen Free with Commercial Standard)**

General Description

The AP8860 is a low-dropout linear regulator that operates in the input voltage range from +2.5V to +7.0V and delivers 1.0A output current.

The AP8860 is available in two types, fixed output voltage type or adjustable output voltage type. The fixed output voltage type is preset at an internally trimmed voltage 1.8V, 2.5V, or 3.3V. Other options 1.5V, 2.85V, 3.0V and 3.6V are available by special order only. The output voltage range of the adjustable type is from 1.25V to 5V.

The AP8860 consists of a 1.25V bandgap reference, an error amplifier, and a P-channel pass-transistor. Other features include short-circuit protection and thermal shutdown protection. The AP8860 devices are available in SOT-223 and TO-252 packages.

Applications

- I Active SCSI Terminators
- I High Efficiency Linear Regulators
- I Monitor Microprocessors
- I Low Voltage Micro-Controllers
- I Post Regulator for Switching Power

Simplified Application Circuit

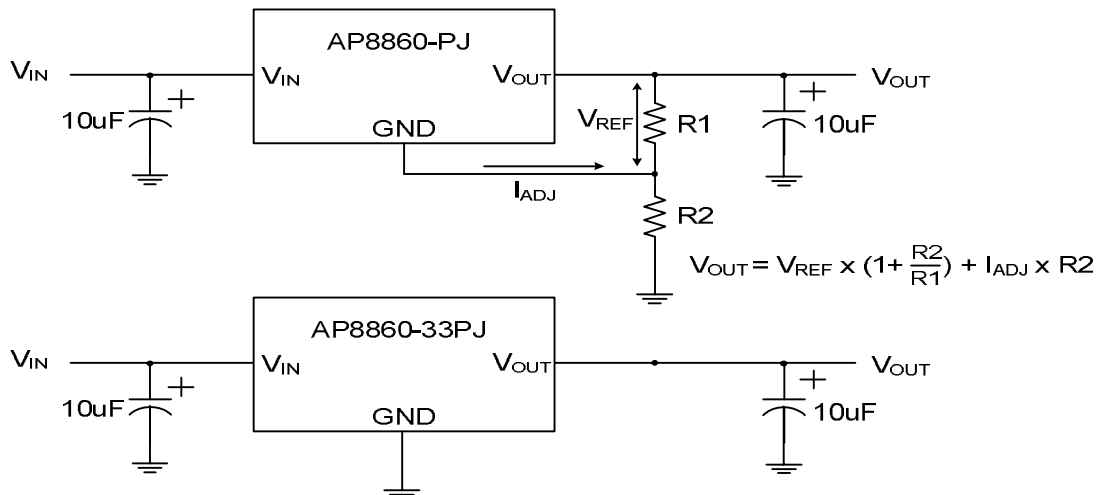

Ordering Information

<p>AP8860 – </p> <p style="margin-left: 40px;"> Output Voltage Accuracy Package Code Lead Free Code V_{OUT}Type </p>	<p>Vout Code : Exam. 18=1.8V · 25=2.5V · 33=3.3V Default : Adjustable Output</p> <p>Lead Free Code : P : Commercial Standard, Lead (Pb) Free And Phosphorous (P) Free Package G : Green (Halogen Free with Commercial Standard)</p> <p>Package Code : G : SOT-223* J : SOT-223* P : TO-252* R : TO-252*</p>
---	--

Note :

* The difference between “G” & “J” type, and “P”& “R” type please refer “Pin Description”.

Pin Description

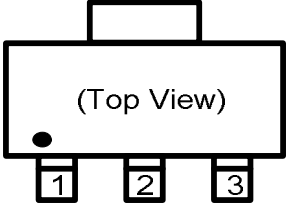
Part NO.	Pin		Symbol	Pin Description
	SOT-223 (G)	SOT-223 (J)		
 (Top View) SOT-223	1	3	V_{IN}	Regulator Input Pin.
	2	1	GND/ADJ	Ground Pin or ADJ Terminal Pin.
	3	2	V_{OUT}	Regulator Output Pin.

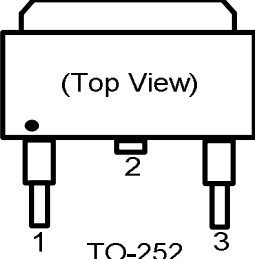
Part NO.	Pin		Symbol	Pin Description
	TO-252 (P)	TO-252 (R)		
 (Top View) TO-252	1	3	V_{IN}	Regulator Input Pin.
	2	1	GND/ADJ	Ground Pin or ADJ Terminal Pin.
	3	2	V_{OUT}	Regulator Output Pin.

Package Marking Information

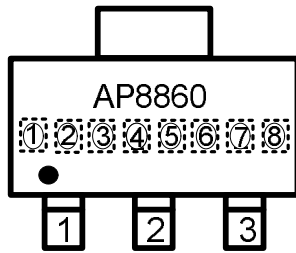

SOT-223
(Top View)

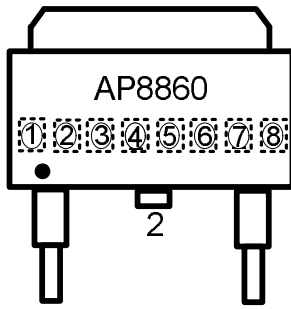

TO-252
(Top View)

Top Point Represents Products Series

Mark	Products Series
Top Point	Part No. : AP8860

①、②、③、④ Represents Products Series

Mark	Description	
①、②	Voltage	Voltage Code or Default (Adjustable)
③	P, G	Pb-Free or Green Code
④	G, J, P, R	Package Code

⑤、⑥、⑦、⑧ Represents Production Date Code

Absolute Maximum Ratings

Parameter	Symbol	Ratings	Units
Input Voltage V_{IN} to GND	V_{IN}	9.0	V
Output Current Limit, I_{LIMIT}	I_{OUT}	1.3	A
Junction Temperature	T_J	+155	°C
Thermal Resistance	θ_{JA}	SOT-223	155
		TO-252	90
Operating Ambient Temperature	T_{OPR}	-40 ~ +125	°C
Storage Temperature	T_{STG}	-55 ~ +150	°C
Lead Temperature (soldering, 10sec)		+260	°C

Note :

* The power dissipation values are based on the condition that junction temperature T_J and ambient temperature T_A difference is 100°C.

* Stresses beyond those listed under “absolute maximum ratings” may cause permanent damage to the device. These are stress ratings only, and function operation of the device at these or any other conditions beyond those indicated under “recommended operating conditions” is not implied. Exposure to absolute-maximum-rated conditions for extended periods may affect device reliability.

Electrical Characteristics

($V_{IN}=5V$, $T_A=25^{\circ}C$, unless otherwise noted.)

Symbol	Parameter	Test Conditions	Min	Typ	Max	Unit
V_{IN}	Input Voltage		2.5		7.0	V
V_{OUT}	Output Voltage	Fixed Voltage Type, $I_{OUT}=1\text{ mA}$, $V_{IN} = V_{OUT}+1.0V$, $V_{IN} \geq 2.5V$	-2%	V_{OUT}	+2%	V
		Adjustable Voltage Type, $I_{OUT}=1\text{ mA}$, $V_{IN} = V_{OUT}+ 1.2V$, $V_{IN} \leq 2.5V$	-50	V_{OUT}	+50	mV
I_{MAX}	Maximum Output Current	(see note *1)	1.0			A
I_{LIMIT}	Current Limit				1.3	A
I_{SC}	Short Circuit Current	$V_{OUT}=0V$		650	760	mA
		$V_{IN}>V_{OUT}+1.2V$ (Adjustable Voltage Type)				
I_Q	Ground Pin Current	$I_{LOAD}=0mA$ to 1A, $V_{IN}=V_{OUT}+1.0V$		100	120	μA
I_{ADJ}	ADJ Pin Current	$I_{LOAD}=0mA$ to 1A, $V_{IN}=V_{OUT}+1.2V$		100	120	μA
V_{DROP}	Dropout Voltage (Fixed Voltage Type)	$I_{OUT}=100mA$		60	100	mV
		$I_{OUT}=500mA$		300	500	mV
		$I_{OUT}=1.0A$		700	1000	mV
ΔV_{LINE}	Line Regulation	$V_{OUT}+1.0V \leq V_{IN} \leq 7.0V$, $I_{LOAD}=1mA$ (Fixed Voltage Type)		0.2	0.3	%/V
		$V_{OUT}+1.2V \leq V_{IN} \leq 7.0V$, $I_{LOAD}=1mA$ (Adjustable Voltage Type)		0.2	0.3	%/V
ΔV_{LOAD}	Load Regulation	$I_{OUT}=0mA$ to 1A (Fixed Voltage Type)		0.02	0.03	%/mA
		$I_{OUT}=0mA$ to 1A (Adjustable Voltage Type)		0.1	0.15	%/mA
e_N	Output Noise	$F=1Hz$ to 10KHz, $C_{OUT}=10\mu F$		80		$\mu V_{(rms)}$
PSRR	Ripple Rejection	$F=1KHz$, $C_{OUT}=10\mu F$		75		dB
T_{SD}	Thermal Shutdown Temperature			155		$^{\circ}C$
T_{HYS}	Thermal Shutdown Hysteresis			20		$^{\circ}C$

Note :

*1) Measured using a double sided board with 1" x 2" square inches of copper area connected to the GND pins for "heat spreading".

AP8860 Function Block Diagram

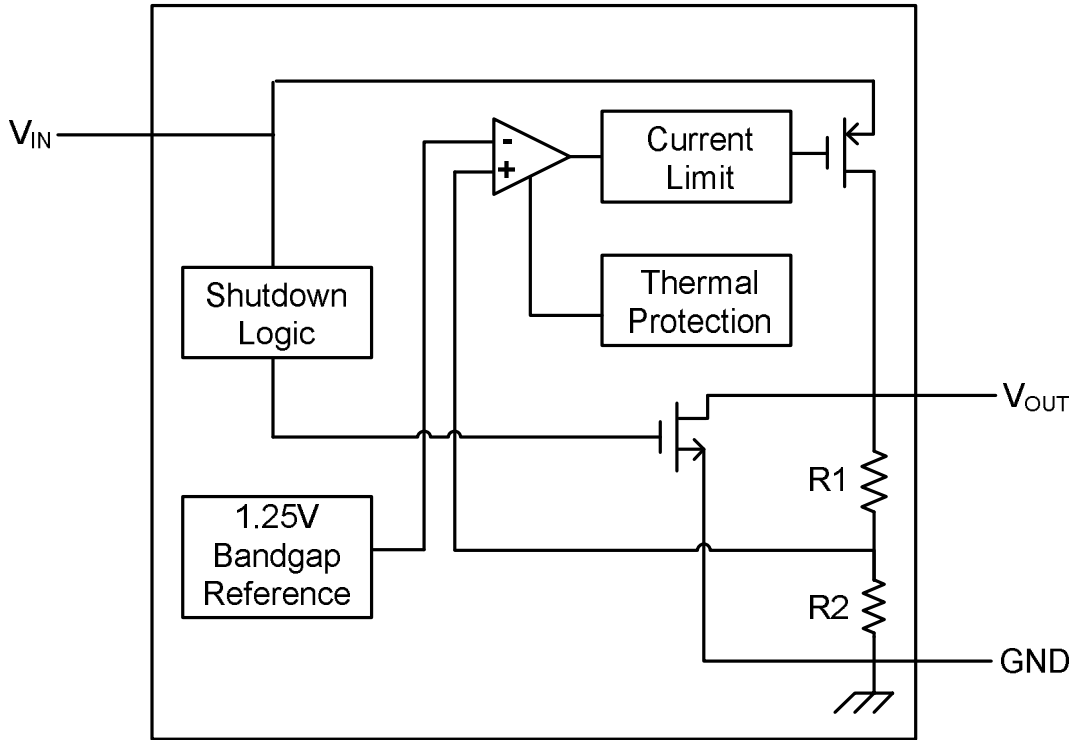

(Fixed Voltage Type)

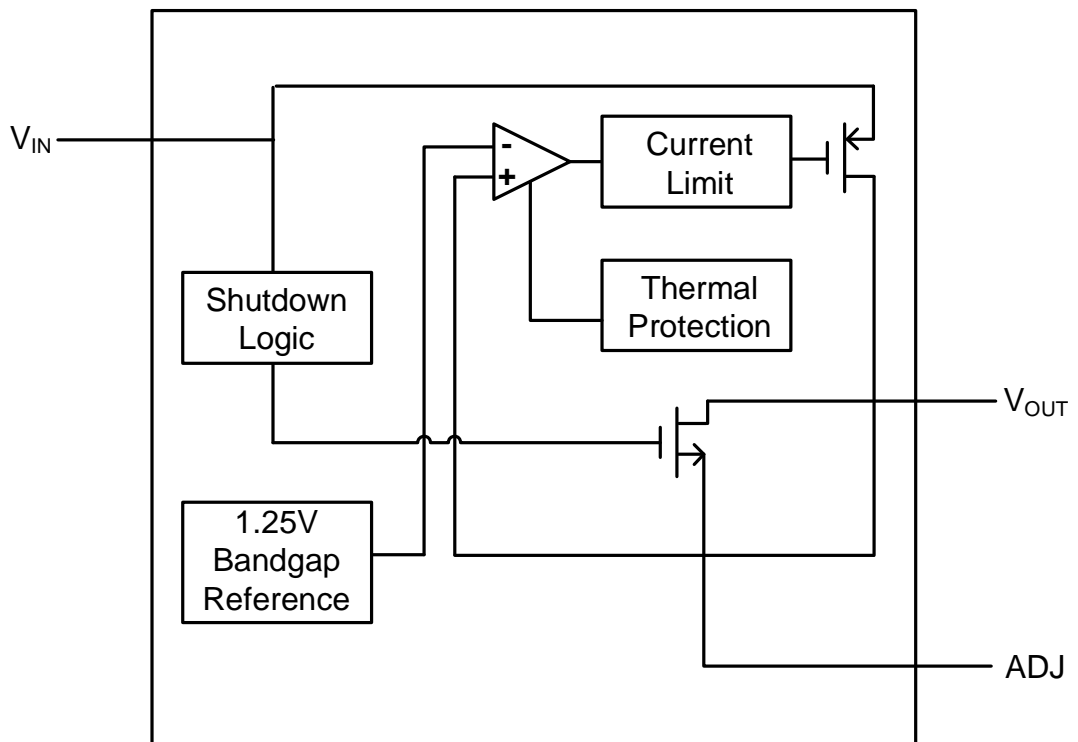

(Adjustable Voltage Type)

Detail Description

The AP8860 is a low-dropout linear regulator. The device provides preset 1.8V 2.5V and 3.3V output voltages for output current up to 1.0A. Adjustable output voltage and other mask options for special output voltages are also available. As illustrated in function block diagram, it consists of a 1.25V bandgap reference, an error amplifier, a P-channel pass transistor and an internal feedback voltage divider (fixed voltage types).

The 1.25V bandgap reference is connected to the error amplifier, which compares this reference with the feedback voltage and amplifies the voltage difference. If the feedback voltage is lower than the reference voltage, the pass-transistor gate is pulled lower, which allows more current to pass to the output pin and increases the output voltage. If the feedback voltage is too high, the pass-transistor gate is pulled up to decrease the output voltage.

The output voltage is feed back through an internal resistive divider (or external resistive divider for adjustable output voltage type) connected to OUT pin. Additional blocks include an output current limiter, thermal sensor, and shutdown logic.

Internal P-channel Pass Transistor

The AP8860 features a P-channel MOSFET pass transistor. Unlike similar designs using PNP pass transistors, P-channel MOSFETs require no base drive, which reduces ground pin current. PNP-based regulators also waste considerable current in dropout when the pass transistor saturates, and use high base-drive currents under large loads. The AP8860 does not suffer from these problems and consumes only 100µA (Typ.) of ground pin current under heavy loads as well as in dropout conditions.

Output Voltage Selection

For fixed voltage type of AP8860, the output voltage is preset at an internally trimmed voltage. The first two digits of part number suffix identify the output voltage (see Ordering Information). For example, the AP8860-33PJ has a preset 3.3V output voltage.

For adjustable voltage type of AP8860, the output voltage is set by comparing the feedback voltage at adjust terminal to the internal bandgap reference voltage. The reference voltage V_{REF} is 1.25V. The output voltage is given by the equation

$$V_{OUT} = V_{REF} * (1 + R2/R1) + I_{ADJ} * R2$$

(see Typical Application Schematic)

Current Limit

The AP8860 also includes a fold back current limiter. It monitors and controls the pass transistor's gate voltage, estimates the output current, and limits the output current within 1.3A.

Thermal Overload Protection

Thermal overload protection limits total power dissipation in the AP8860. When the junction temperature exceeds $T_J = +155^\circ\text{C}$, a thermal sensor turns off the pass transistor, allowing the IC to cool down. The thermal sensor turns the pass transistor on again after the junction temperature cools down by 20°C , resulting in a pulsed output during continuous thermal overload conditions. Thermal overload protection is designed to protect the AP8860 in the event of fault conditions. For continuous operation, the maximum operating junction temperature rating of $T_J = +155^\circ\text{C}$ should not be exceeded.

Operating Region and Power Dissipation

Maximum power dissipation of the AP8860 depends on the thermal resistance of the case and circuit board, the temperature difference between the die junction and ambient air, and the rate of airflow. The power dissipation across the devices is $P = I_{OUT} \times (V_{IN} - V_{OUT})$. The resulting maximum power dissipation is:

$$P_{MAX} = \frac{(T_J - T_A)}{q_{JC} + q_{CA}} = \frac{(T_J - T_A)}{q_{JA}}$$

AP8860 Series

Where $(T_J - T_A)$ is the temperature difference between the AP8860 die junction and the surrounding air, θ_{JC} is the thermal resistance of the package chosen, and θ_{CA} is the thermal resistance through the printed circuit board, copper traces and other materials to the surrounding air. For better heat-sinking, the copper area should be equally shared between the IN, OUT, and GND pins.

If the AP8860 uses a SOT-223 package and this package is mounted on a double sided printed circuit board with two square inches of copper allocated for "heat spreading", the resulting θ_{JA} is 80 °C/W. Based on the maximum operating junction temperature 125 °C with an ambient of 25°C, the maximum power dissipation will be:

$$P_{MAX} = \frac{(T_J - T_A)}{q_{JC} + q_{CA}} = \frac{(125 - 25)}{80} = 1.25W$$

Thermal characteristics were measured using a double-sided board with 1" x 2" square inches of copper area connected to the GND pin for "heat spreading". Input-Output Voltage A regulator's minimum input-output voltage differential, or dropout voltage, determines the lowest usable supply voltage. In battery-powered systems, this will determine the useful end-of-life battery voltage. The AP8860 uses a P-channel MOSFET pass transistor, its dropout voltage is a function of drain-to-source on-resistance ($R_{DS(ON)}$) multiplied by the output current.

$$V_{DROPOUT} = V_{IN} - V_{OUT} = R_{DS(ON)} \times I_{OUT}$$

Application Note

$V_{OUT}(V)$	$R1(\Omega)$	$R2(\Omega)$
1.5	240	47
1.8	240	105
2.5	240	240
2.8	240	300
3.0	240	332
3.3	240	390
3.6	240	442

Suggested resistance to the various V_{OUT}

Typical Operating Characteristics

($C_{IN}=10\mu F$, $C_{OUT}=3.3\mu F$, $T_A=+25^\circ C$, unless otherwise noted.)

OUTPUT VOLTAGE vs. INPUT VOLTAGE

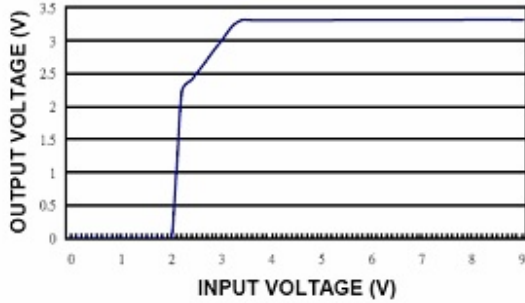

GROUND PIN CURRENT vs. AMBIENT TEMPERATURE

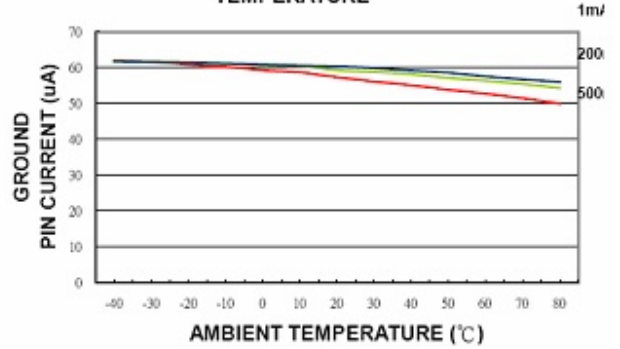

DROPOUT VOLTAGE vs. LOAD CURRENT

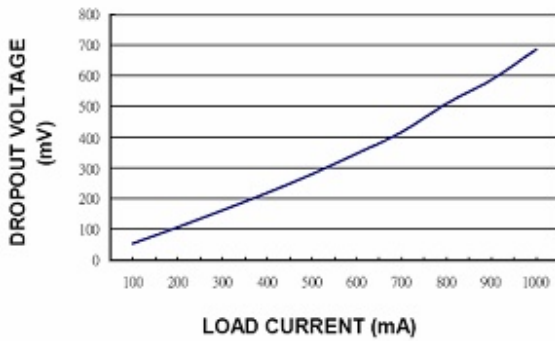

Ron vs. LOAD CURRENT

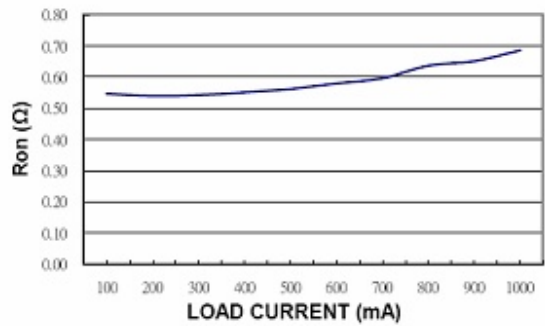

POWER SUPPLY REJECTION RATIO vs. FREQUENCY

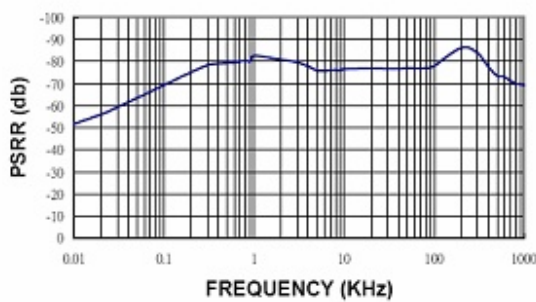

GROUND PIN CURRENT vs. LOAD CURRENT

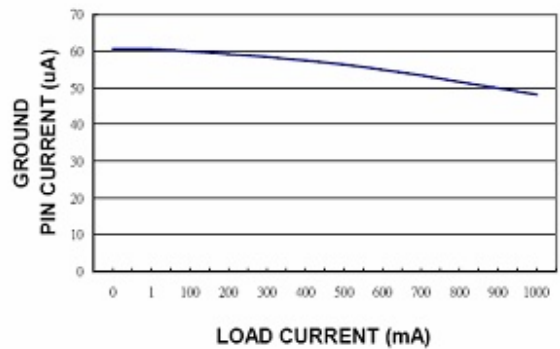

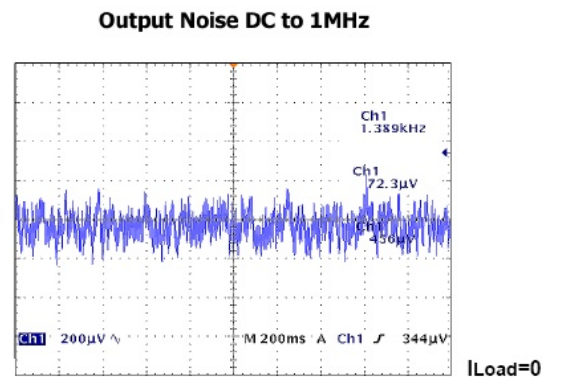
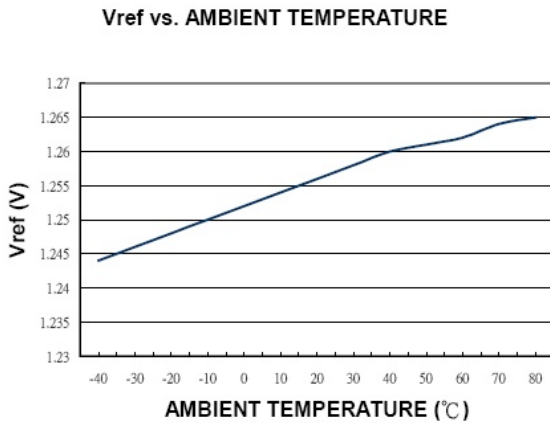
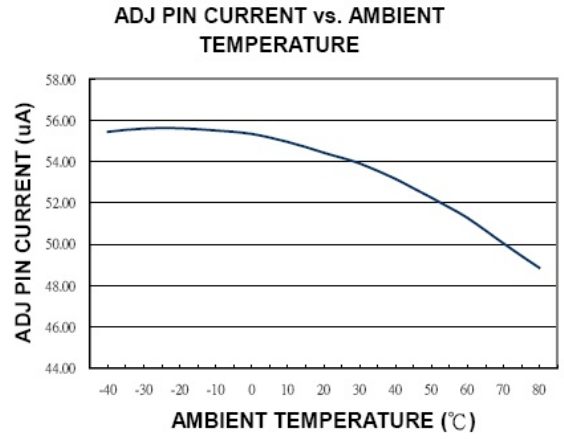
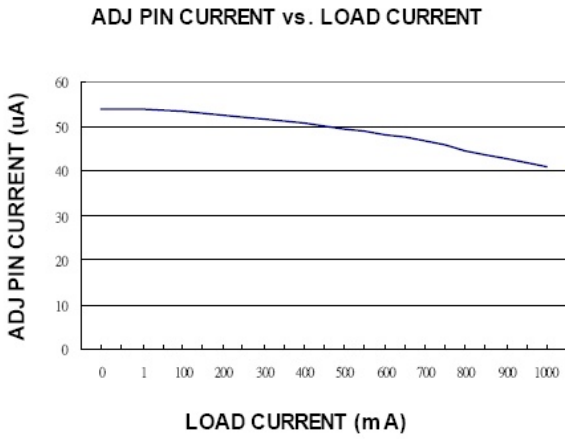
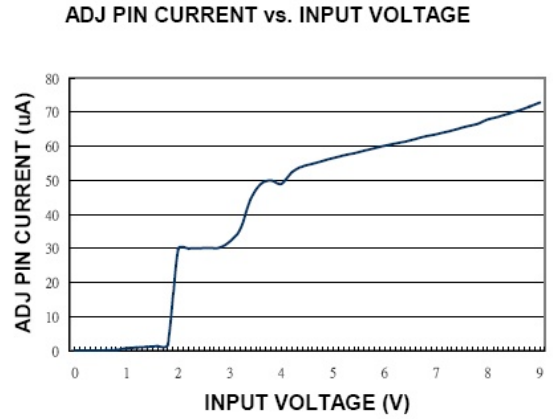
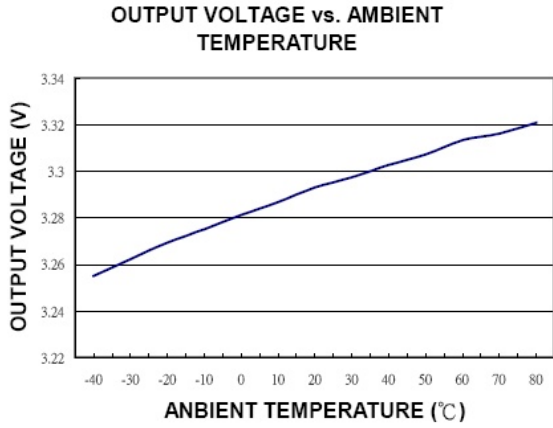

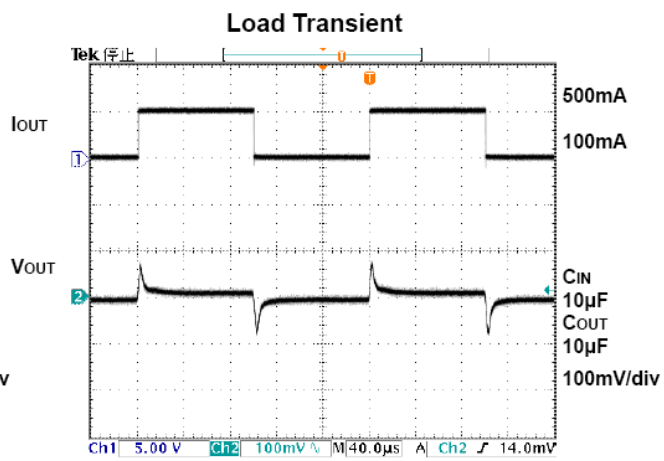
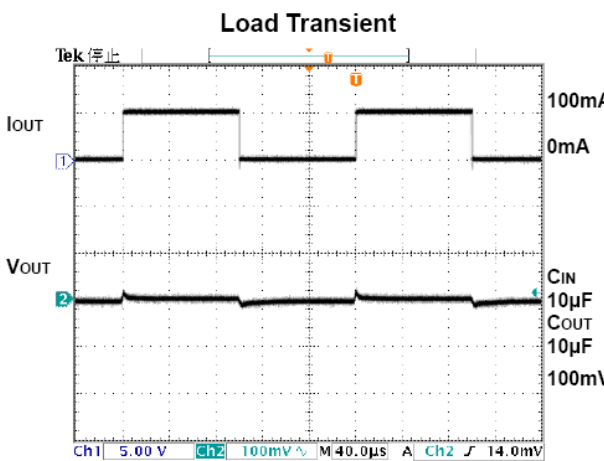
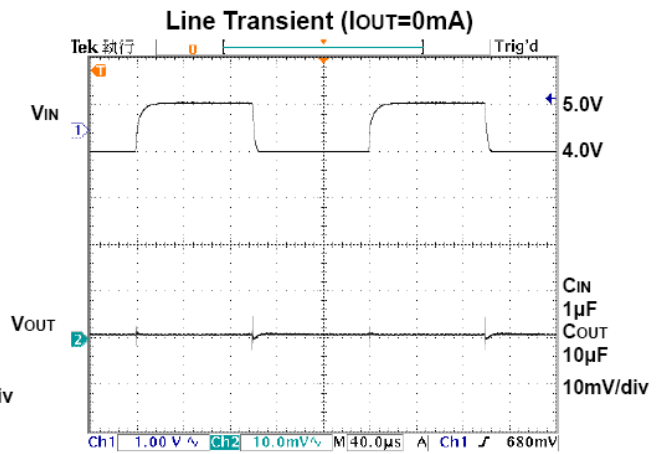
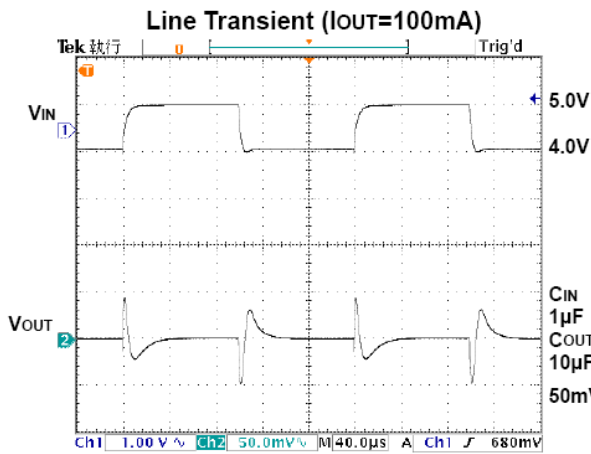
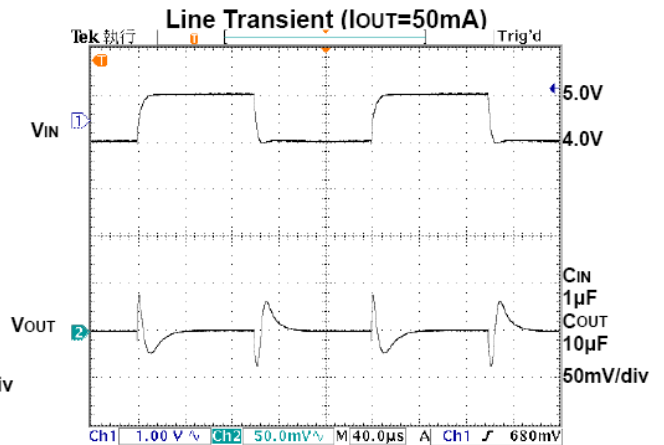
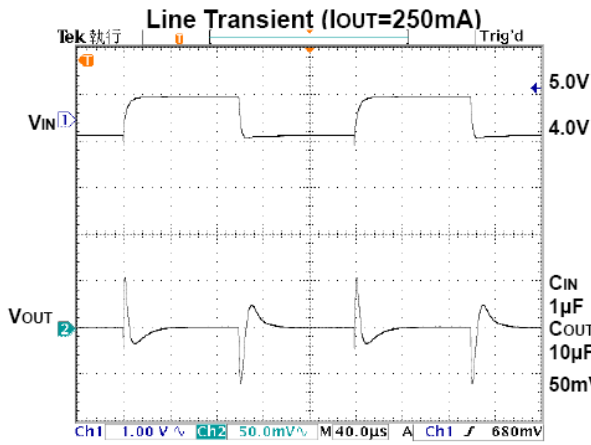

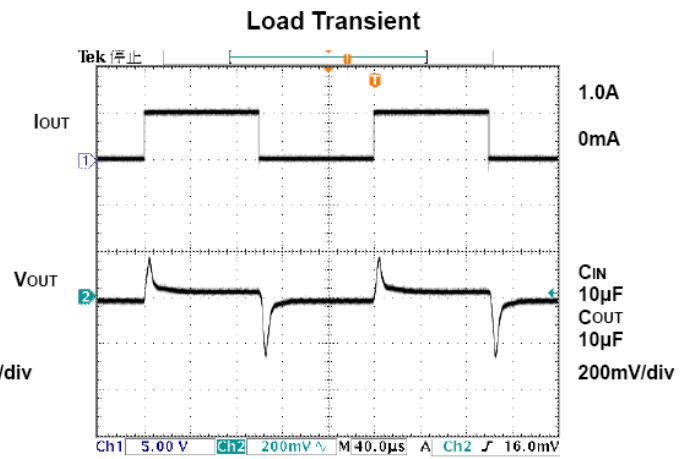
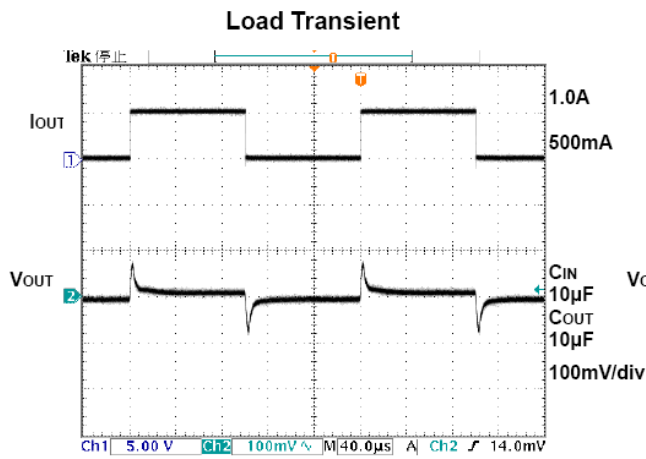

Package Outline

A) SOT-223

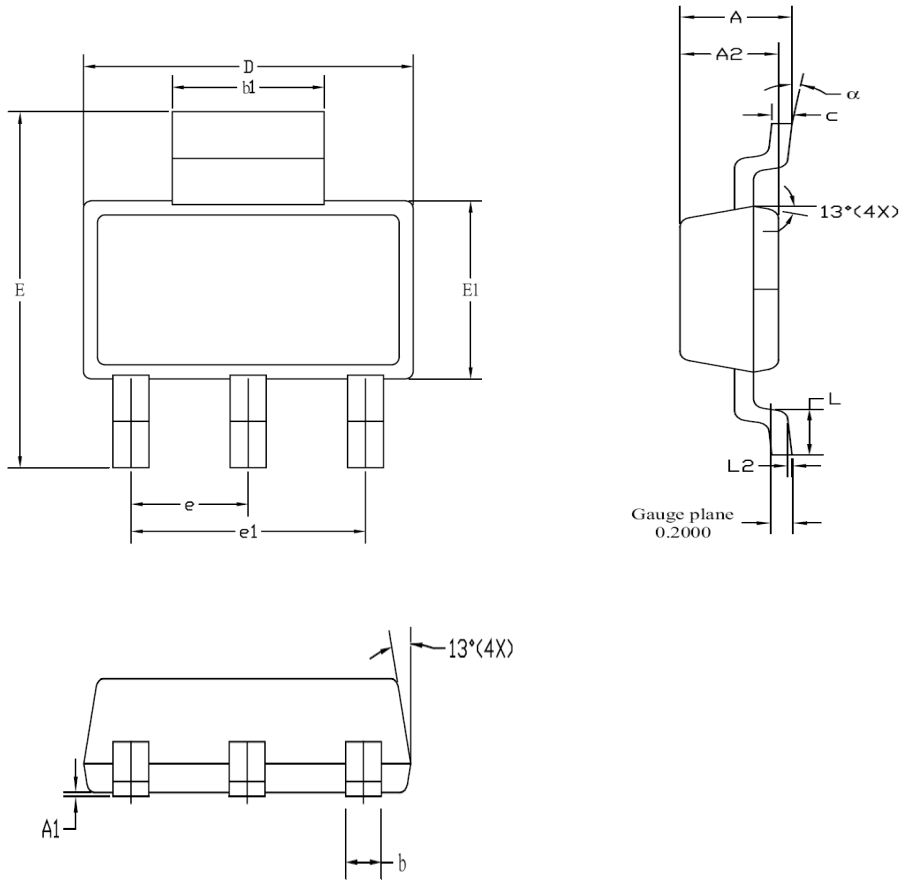

Symbols	Millimeters		Inches	
	Min	Max	Min	Max
A	1.52	1.80	0.061	0.071
A1	0.02	0.10	0.0008	0.0040
A2	1.50	1.70	0.059	0.067
b	0.60	0.80	0.024	0.031
b1	2.90	3.10	0.114	0.122
C	0.24	0.32	0.009	0.013
D	6.30	6.80	0.248	0.268
E1	3.30	3.70	0.130	0.146
e	2.30 BSC		0.090 BSC	
e1	4.60 BSC		0.181 BSC	
E	6.70	7.30	0.264	0.287
L	0.90 MIN		0.036 MIN	
L2	0.06 BSC		0.0024 BSC	
α	0°	10°	0°	10°

B) TO-252

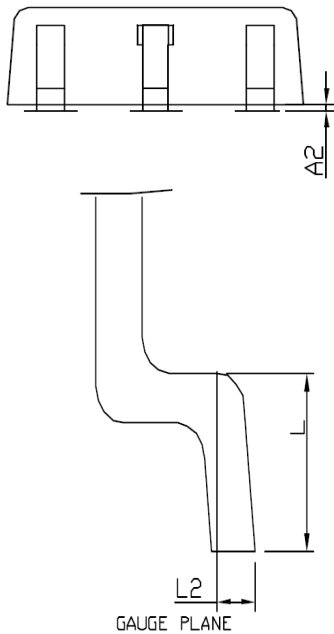
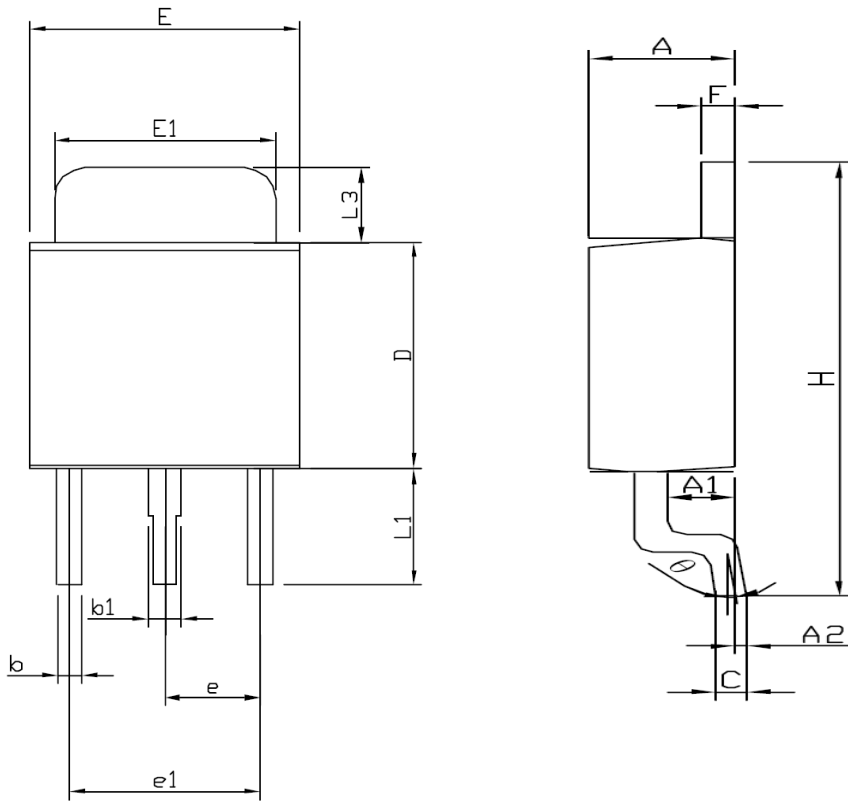

Symbols	Millimeters		Inches	
	Min	Max	Min	Max
A	2.19	2.38	0.086	0.094
A1	0.89	1.27	0.035	0.050
A2	0.00	0.13	0.000	0.005
b	0.51	0.69	0.020	0.027
b1	0.71	0.89	0.028	0.035
C	0.46	0.58	0.018	0.023
D	5.36	5.61	0.211	0.221
E	6.35	6.73	0.250	0.265
E1	5.21	5.46	0.205	2.215
e	2.28 BSC		0.090 BSC	
e1	4.19	4.95	0.165	0.195
F	0.46	0.58	0.018	0.023
L	1.40	1.78	0.055	0.070
L1	2.20	2.80	0.087	0.110
L2	0.51 BSC		0.020BSC	
L3	1.14	1.65	0.045	0.065
H	8.90	9.90	0.350	0.390
θ	0°	4°	0°	4°

Reflow Condition (IR/Convection or VPR Reflow)

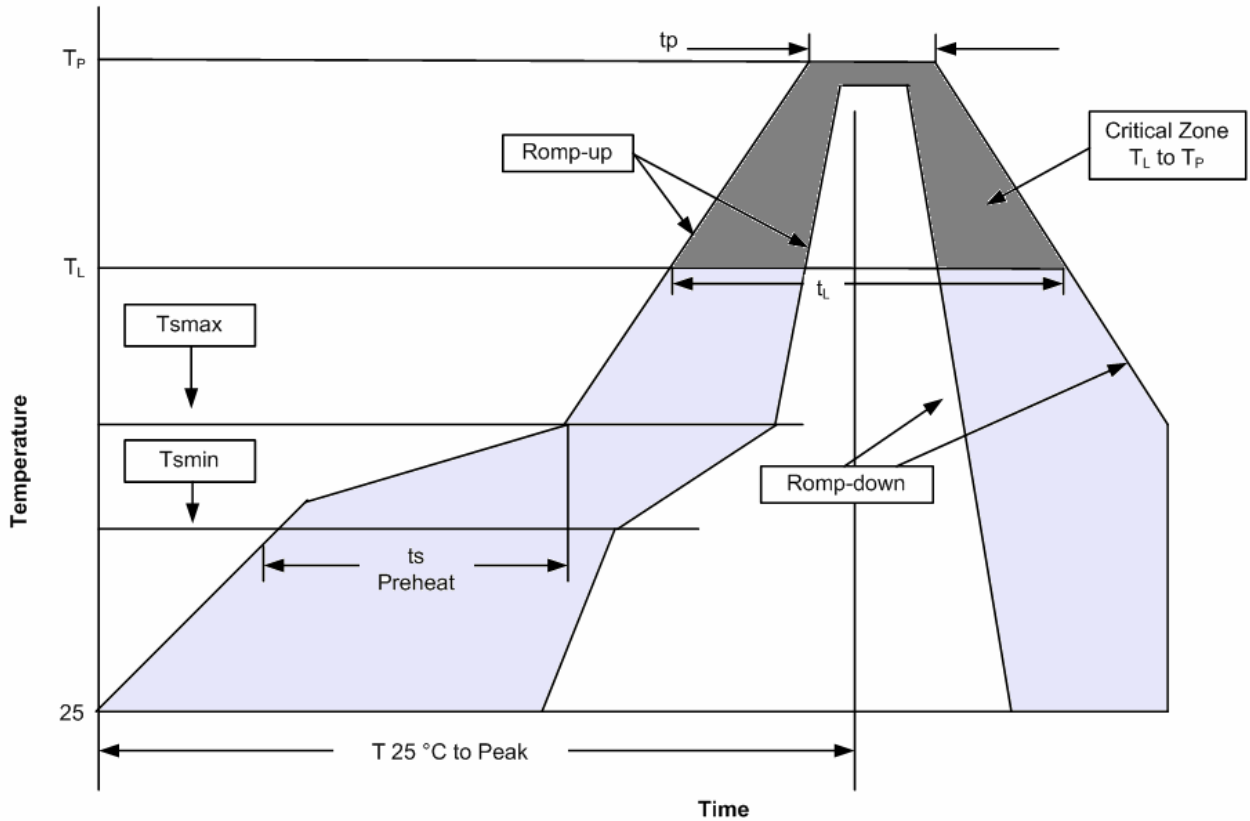

Classification Reflow Profiles

Profile Feature	Pb-Free / Green Assembly
Average ramp-up rate (T_L to T_P)	3°C/second max
Preheat - Temperature Min (T_{min}) - Temperature Max (T_{max}) - Time (min to max) (t_s)	150°C 200°C 60-180 seconds
Time maintained above: - Temperature (T_L) - Time (t_L)	217°C 60-150 seconds
Peak/Classification Temperature (T_P)	See table 1
Time within 5°C of actual Peak Temperature (t_p)	20-40 seconds
Ramp-down Rate	6°C/second max
Time 25°C to Peak Temperature	8 minutes max

Notes :

- 1) All temperatures refer to topside of the package.
- 2) Measured on the body surface.

Classification Reflow Profiles (Continued)

Table 1. Pb-free / Green Process – Package Classification Reflow Temperatures

Package Thickness	Volume mm³ <350	Volume mm³ 350~2000	Volume mm³ ≥2000
<2.5 mm	260 +0°C*	260 +0°C*	260 +0°C*
1.6-2.5 mm	260 +0°C*	250 +0°C*	245 +0°C*
≥2.5 mm	250 +0°C*	245 +0°C*	245 +0°C*

Notes :

* Tolerance: The device manufacturer/supplier shall assure process compatibility up to and including the stated classification temperature (this means Peak reflow temperature +0°C. For example 260°C+0°C) at the rated MSL level.