

## Stereo, Differential Input Cap-Free Line Driver

### Features

- **Operating Voltage: 2.3V~5.5V**
- **Differential Input**
- **Ground Reference Output**
  - No Output Capacitor Required (for DC Blocking)
  - Save the PCB Space
  - Reduce the BOM Costs
  - Improve the Low Frequency Response
- **Low Noise and THD+N**
  - SNR > 108dB
  - Noise < 8mV<sub>rms</sub>
  - THD+N < 0.02% at 20Hz~20kHz
- **Output Voltage Swing Can Reach 2.1V<sub>rms</sub>/Ch into 2.5kW at V<sub>DD</sub>=3.3V**
- **High PSRR: 80dB at 217Hz**
- **Fast Start-up Time: 500ms**
- **Integrate the De-Pop Circuitry**
- **Thermal and Short-Circuit Protection**
- **Surface-Mount Packaging**
  - MSOP-10P
- **Lead Free and Green Devices Available (RoHS Compliant)**

### Applications

- Set-Top Boxes
- CD/DVD Players
- LCD TVs
- HTIBs (Home Theater in Box)

### General Description

The APA2173 is a stereo, differential input, single supply, and cap-free line driver, which is available in MSOP-10P package.

The APA2173 is ground-reference output, and doesn't need the output capacitors for DC blocking. The advantages of eliminating the output capacitor are saving the cost, eliminating component height, and improving the low frequency response.

The external gain setting is recommended using from  $\pm 1V/V$  to  $\pm 10V/V$ . High PSRR provides increased immunity to noise and RF rectification. APA2173 has shutdown and under-voltage detector function for Depop solution. The APA2173 is capable of driving 2.1V<sub>rms</sub> at 3.3V into 2.5k $\Omega$  load, and provides short-circuit and thermal protection.

### Simplified Application Circuit

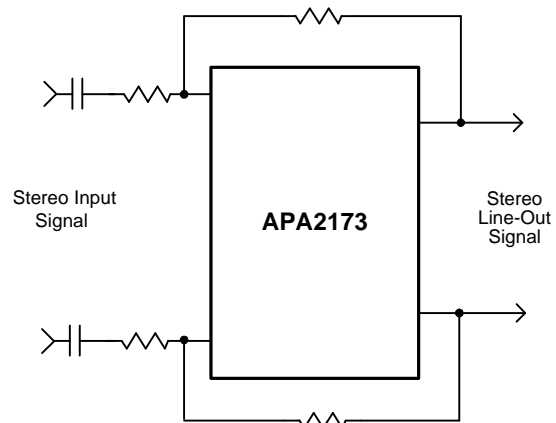

ANPEC reserves the right to make changes to improve reliability or manufacturability without notice, and advise customers to obtain the latest version of relevant information to verify before placing orders.

## Pin Configuration

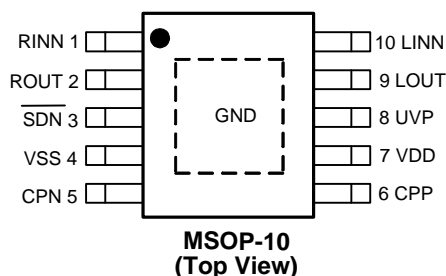

## Ordering and Marking Information

<p>APA2173    □□□-□□□</p> <ul style="list-style-type: none"> <li>□□□ - Assembly Material</li> <li>□□ - Handling Code</li> <li>□ - Temperature Range</li> <li>□ - Package Code</li> </ul>	<p>Package Code                  XA: MSOP-10P                  Operating Ambient Temperature Range                  I : -40 to 85°C                  Handling Code                  TR : Tape &amp; Reel                  Assembly Material                  G : Halogen and Lead Free Device</p>
<p>APA2173 XA :    </p>	<p>XXXXX - Date Code</p>

Note: ANPEC lead-free products contain molding compounds/die attach materials and 100% matte tin plate termination finish; which are fully compliant with RoHS. ANPEC lead-free products meet or exceed the lead-free requirements of IPC/JEDEC J-STD-020D for MSL classification at lead-free peak reflow temperature. ANPEC defines “Green” to mean lead-free (RoHS compliant) and halogen free (Br or Cl does not exceed 900ppm by weight in homogeneous material and total of Br and Cl does not exceed 1500ppm by weight).

## Absolute Maximum Ratings (Note 1)

Symbol	Parameter	Rating	Unit
$V_{PGND\_GND}$	PGND to GND Voltage	-0.3 to 0.3	V
$V_{DD}$	Supply Voltage (VDD to GND and PGND)	-0.3 to 6.0	
$V_{SDN}$	Input Voltage (SDN to GND)	$V_{GND}-0.3$ to $V_{DD}+0.3$	
$V_{SS}$	VSS to GND and PGND Voltage	-6.0 to 0.3	
$V_{OUT}$	ROUT and LOU to GND Voltage	$V_{SS}-0.3$ to $V_{DD}+0.3$	
$V_{CPP}$	CPP to PGND Voltage	$V_{PGND}-0.3$ to $V_{DD}+0.3$	
$V_{CPN}$	CPN to PGND Voltage	$V_{SS}-0.3$ to $V_{PGND}+0.3$	
$T_J$	Maximum Junction Temperature	150	°C
$T_{STG}$	Storage Temperature Range	-65 to +150	
$T_{SDR}$	Maximum Soldering Temperature Range, 10 Seconds	260	
$P_D$	Power Dissipation	Internally Limited	W

Note 1: Absolute Maximum Ratings are those values beyond which the life of a device may be impaired. Exposure to absolute maximum rating conditions for extended periods may affect device reliability.

### Thermal Characteristics

Symbol	Parameter	Typical Value	Unit
$\theta_{JA}$	Thermal Resistance - Junction to Ambient <sup>(Note 2)</sup> MSOP-10P	60	$^{\circ}\text{C}/\text{W}$

Note 2: Please refer to “Thermal Pad Consideration”. 2 layered 5 in2 printed circuit boards with 2oz trace and copper through several thermal vias. The thermal pad is soldered on the PCB.

### Recommended Operating Conditions

Symbol	Parameter	Range		Unit
		Min.	Max.	
$V_{DD}$	Supply Voltage	2.3	5.5	V
$V_{IH}$	High Level Threshold Voltage	SDN	1.0	
$V_{IL}$	Low Level Threshold Voltage	SDN	-	
$T_A$	Operating Ambient Temperature Range	-40	85	$^{\circ}\text{C}$
$T_J$	Operating Junction Temperature Range	-40	125	$^{\circ}\text{C}$
$R_L$	Load Resistance	16	100k	$\Omega$

### Electrical Characteristics

$V_{DD}=3.3\text{V}$ ,  $V_{GND}=V_{PGND}=0\text{V}$ ,  $V_{SDN}=V_{DD}$ ,  $C_{CPF}=C_{CPO}=1\mu\text{F}$ ,  $C_i=2.2\mu\text{F}$ ,  $R_L=2.5\text{k}\Omega$ ,  $T_A=25^{\circ}\text{C}$ ,  $R_i=10\text{k}\Omega$ ,  $R_f=20\text{k}\Omega$  (unless otherwise noted)

Symbol	Parameter	Test Conditions	APA2173			Unit
			Min.	Typ.	Max.	
$I_{DD}$	$V_{DD}$ Supply Current		-	10	15	mA
$I_{SD}$	$V_{DD}$ Shutdown Current	$V_{SDN}=0\text{V}$	-	1	5	$\mu\text{A}$
$I_i$	Input Current	SDN	-	0.1	-	$\mu\text{A}$
<b>CHARGE PUMP</b>						
$f_{OSC}$	Switching Frequency		400	500	600	kHz
$R_{eq}$	Equivalent Resistance		-	21	25	$\Omega$
<b>DRIVERS</b>						
$A_{VO}$	Open Loop Voltage Gain		80	100	-	dB
GW	Unity Gain Bandwidth		8	10	-	MHz
$V_{SR}$	Slew Rate		-	4.5	-	V/ $\mu\text{s}$
$V_{OS}$	Output Offset Voltage	$V_{DD}=2.3\text{V}$ to $5.5\text{V}$ , $R_L = 2.5\text{k}\Omega$	-5	-	5	mV
$V_N$	Output Noise	$R_i=10\text{k}\Omega$ , $R_f=10\text{k}\Omega$	-	8	15	$\mu\text{V}_{rms}$
$T_{start-up}$	Start-up Time		-	500	-	$\mu\text{s}$
PSRR	Power Supply Rejection Ratio	$V_{DD}=2.3\text{V}$ to $5.5\text{V}$ , $V_{rr}=200\text{mV}_{rms}$ $f_{in}= 217\text{Hz}$ $f_{in}= 1\text{kHz}$ $f_{in}= 20\text{kHz}$	-	-80 -80 -50	-60 -60 -45	dB
$C_L$	Maximum Capacitive Load		-	220	-	pF
$V_{ESD}$	ESD Protection	OUTR, OUTL	-	8	-	kV

**Electrical Characteristics (Cont.)**

$V_{DD}=3.3V$ ,  $V_{GND}=V_{PGND}=0V$ ,  $V_{SDN}=V_{DD}$ ,  $C_{CPF}=C_{CPO}=1\mu F$ ,  $C_i=2.2\mu F$ ,  $R_L=2.5k\Omega$ ,  $T_A=25^\circ C$ ,  $R_i=10k\Omega$ ,  $R_f=20k\Omega$  (unless otherwise noted)

Symbol	Parameter	Test Conditions	APA2173			Unit
			Min.	Typ.	Max.	
$V_O$	Output Voltage (Stereo, In Phase)	THD+N=1%, $f_{in}=1kHz$ $R_L=2.5k\Omega$ $R_L=100k\Omega$	2.0 -	2.1 2.3	-	V
$P_O$	Output Power (Stereo, In Phase)	THD+N=1%, $f_{in}=1kHz$ $R_L=32\Omega$	-	20	-	mW
		VDD=5V THD+N=1%, $f_{in}=1kHz$ $R_L=32\Omega$	-	60	-	
THD+N	Total Harmonic Distortion Plus Noise	$V_O=2V_{rms}$ , $R_L=2.5k\Omega$ $f_{in}=20Hz$ $f_{in}=1kHz$ $f_{in}=20kHz$	-	0.02 0.001 0.02	- 0.002 -	%
		$P_O=10mW$ , $R_L=32\Omega$ , $f_{in}=1kHz$	-	0.03	-	
		VDD=5V, $P_O=30mW$ , $R_L=32\Omega$ , $f_{in}=1kHz$	-	0.03	-	
Crosstalk	Channel Separation	$V_O=2V_{rms}$ , $R_L=2.5k\Omega$ $f_{in}=20Hz$ $f_{in}=1kHz$ $f_{in}=20kHz$	-	100 100 90	-	dB
S/N	Signal to Noise Ratio	$V_O=2V_{rms}$ , $R_L=2.5k\Omega$ , $R_i=10k\Omega$ , $R_f=10k\Omega$ , With A-weighting Filter	102	108	-	dB
$T_{SD}$	Thermal Shutdown Protection Temperature		-	150	-	$^\circ C$
<b>UVP FUNCTION</b>						
$V_{UVP}$	External Under Voltage Detection		-	1.25	-	V
$I_{HYS}$	External Under Voltage Detection Hysteresis Current		-	5.0	-	$\mu A$

### Typical Operating Characteristics

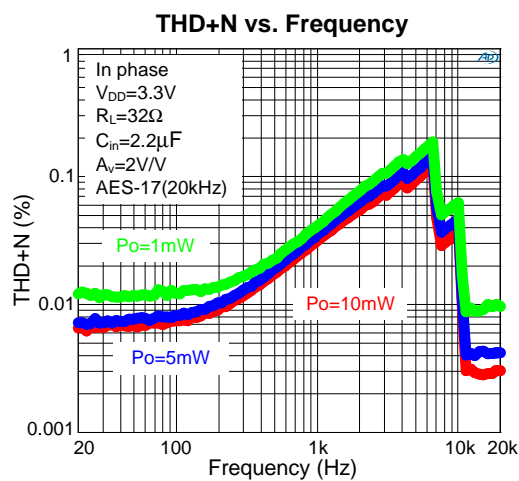
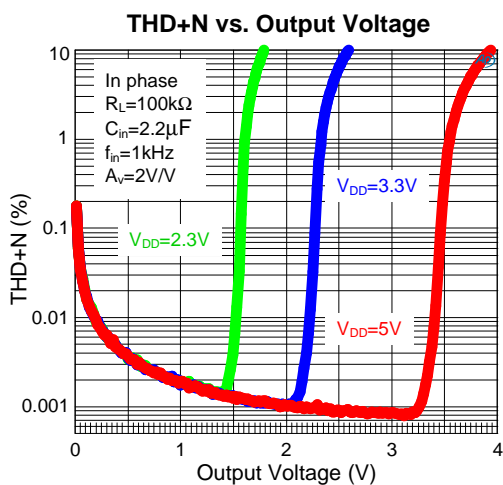
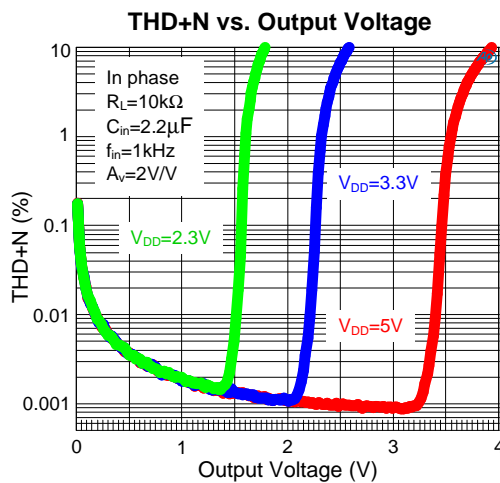
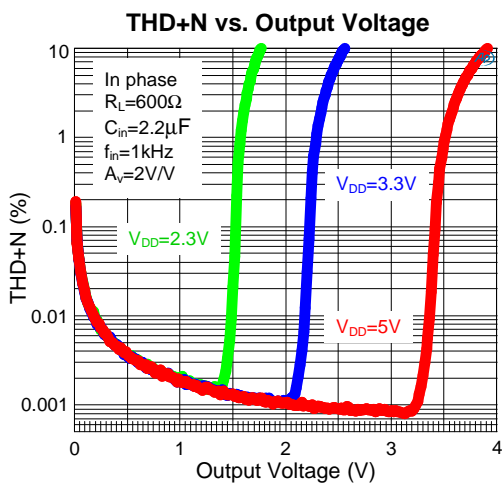
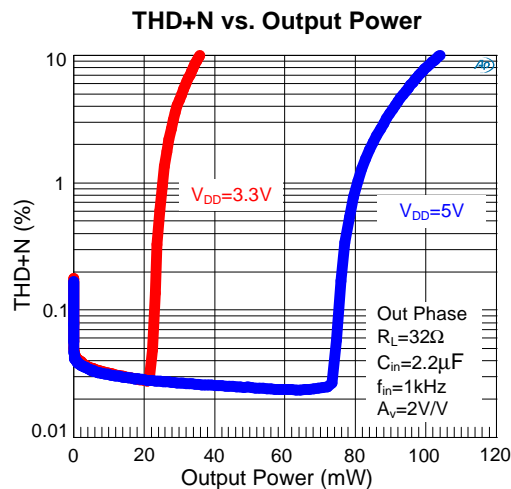
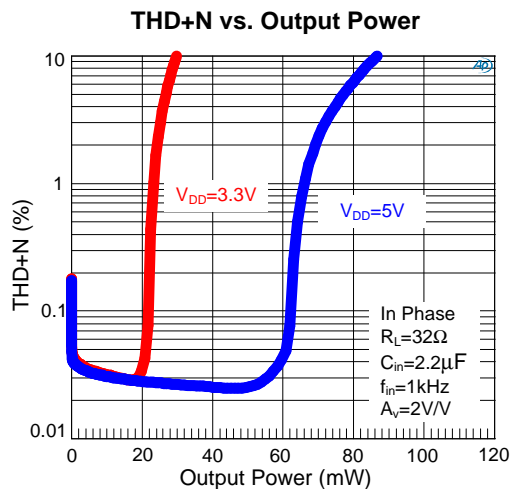

### Typical Operating Characteristics

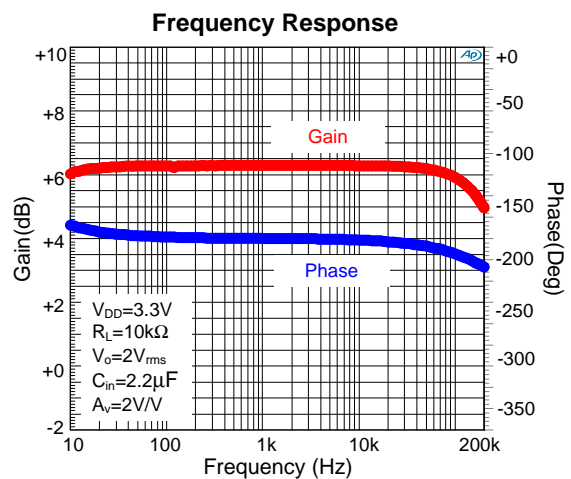
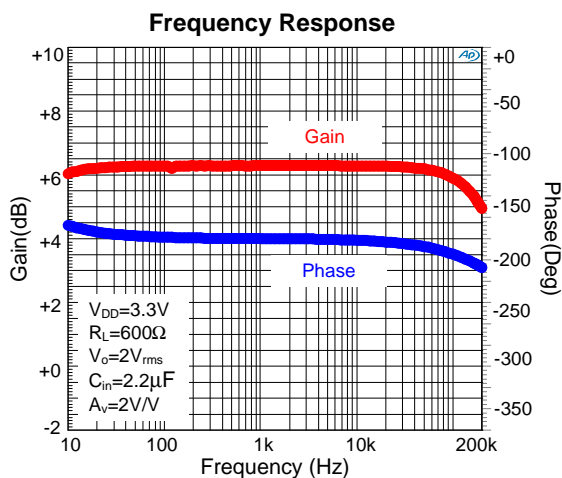
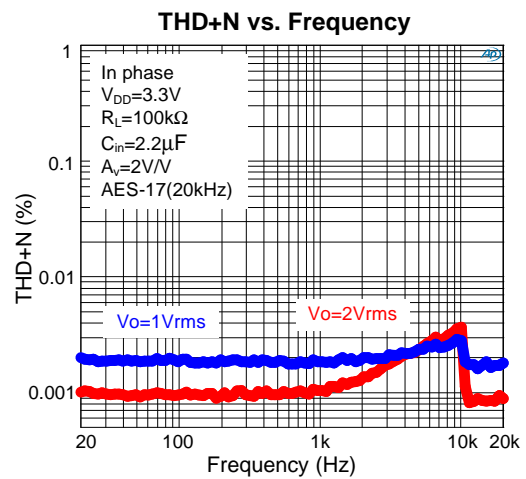
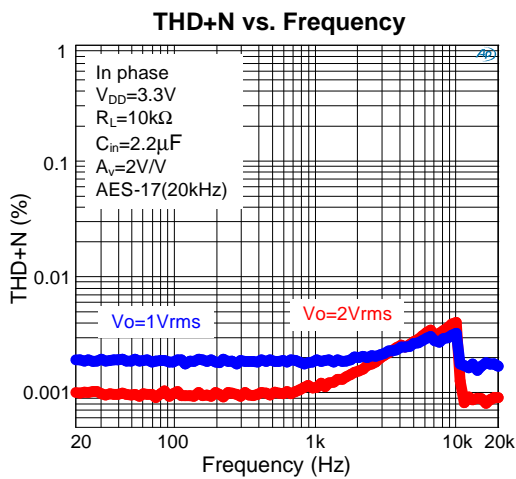
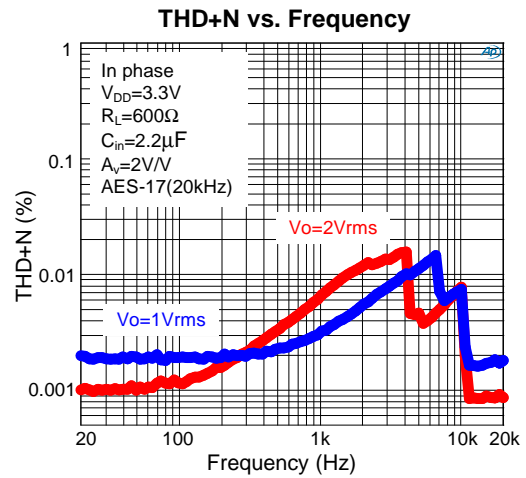
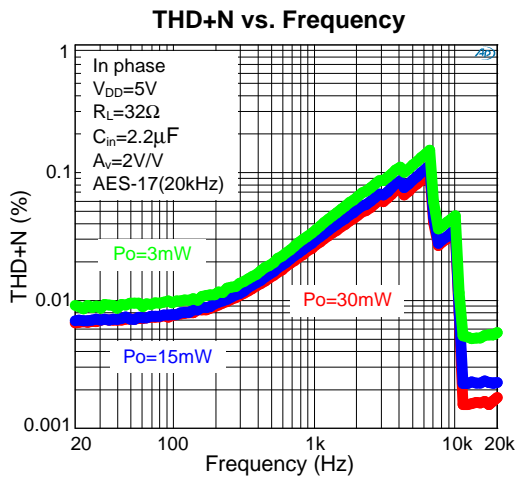

### Typical Operating Characteristics (Cont.)

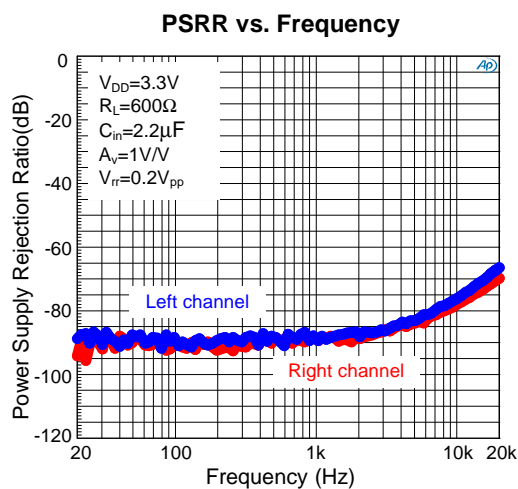
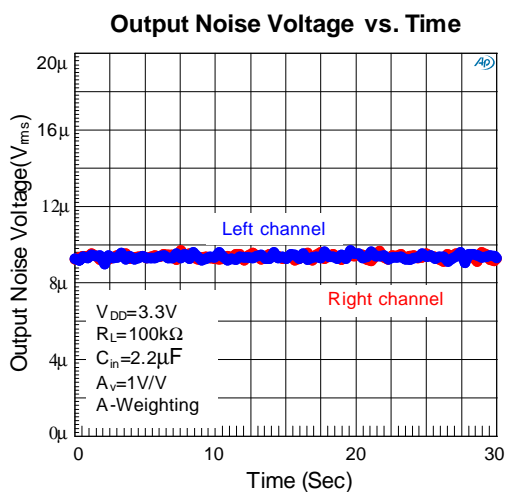
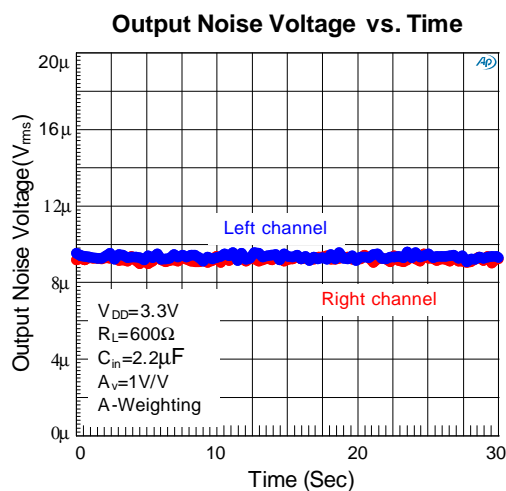
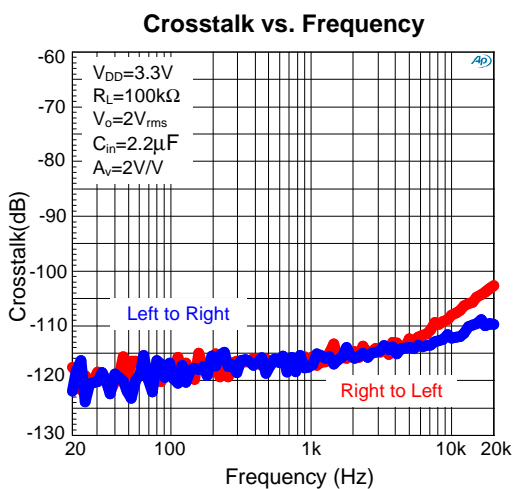
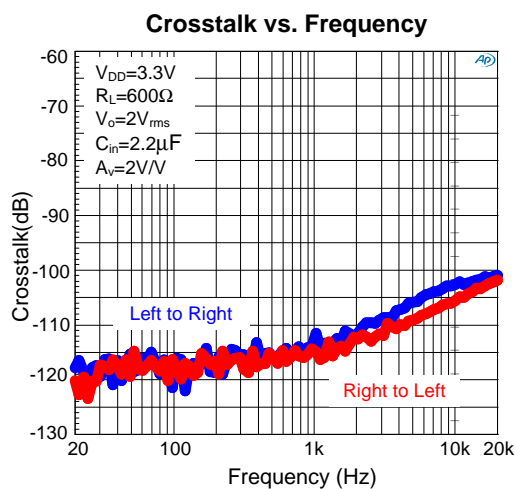
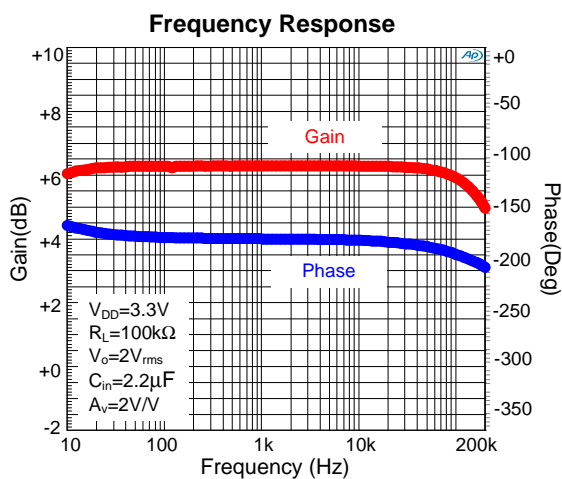

Typical Operating Characteristics (Cont.)

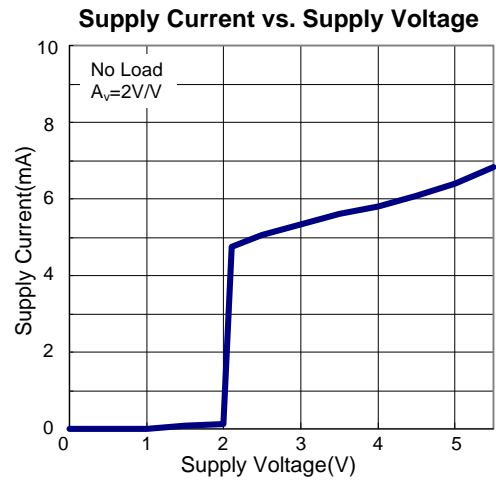
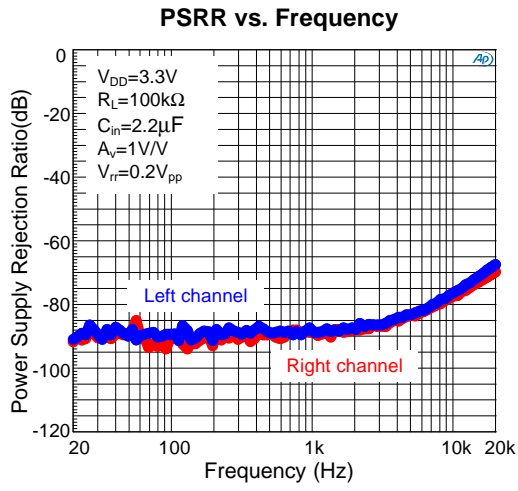



### Pin Description

PIN		I/O/P	FUNCTION
NO.	NAME		
1	RINN	I	Right channel inverting input.
2	ROUT	O	Right channel output.
3	$\overline{\text{SDN}}$	I	Shutdown mod control input signal, pull low for shutdown headphone driver. This pin should be connect a 100Ω Protection Resistor.
4	VSS	P	Headphone driver negative power supply.
5	CPN	I/O	Charge pump flying capacitor negative connection.
6	CPP	I/O	Charge pump flying capacitor positive connection.
7	VDD	P	Supply voltage input.
8	UVP	I	Under voltage protection input. Floating or Pull "H" to disable this function.
9	LOUT	O	Left channel output.
10	LINN	I	Left channel inverting input.
Exposed Pad	GND	P	Signal ground.

### Block Diagram

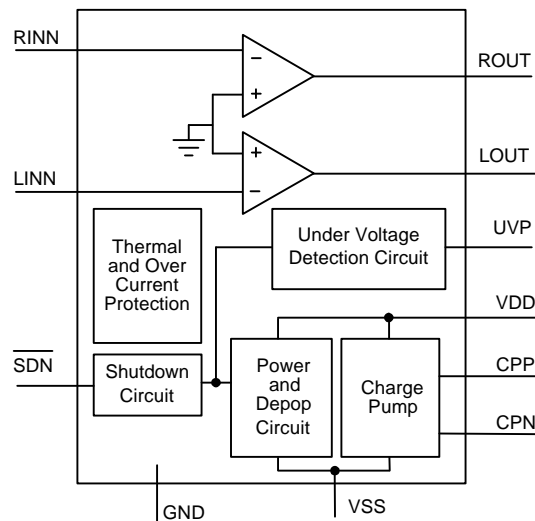

## Typical Application Circuit

### Line Driver Amplifier

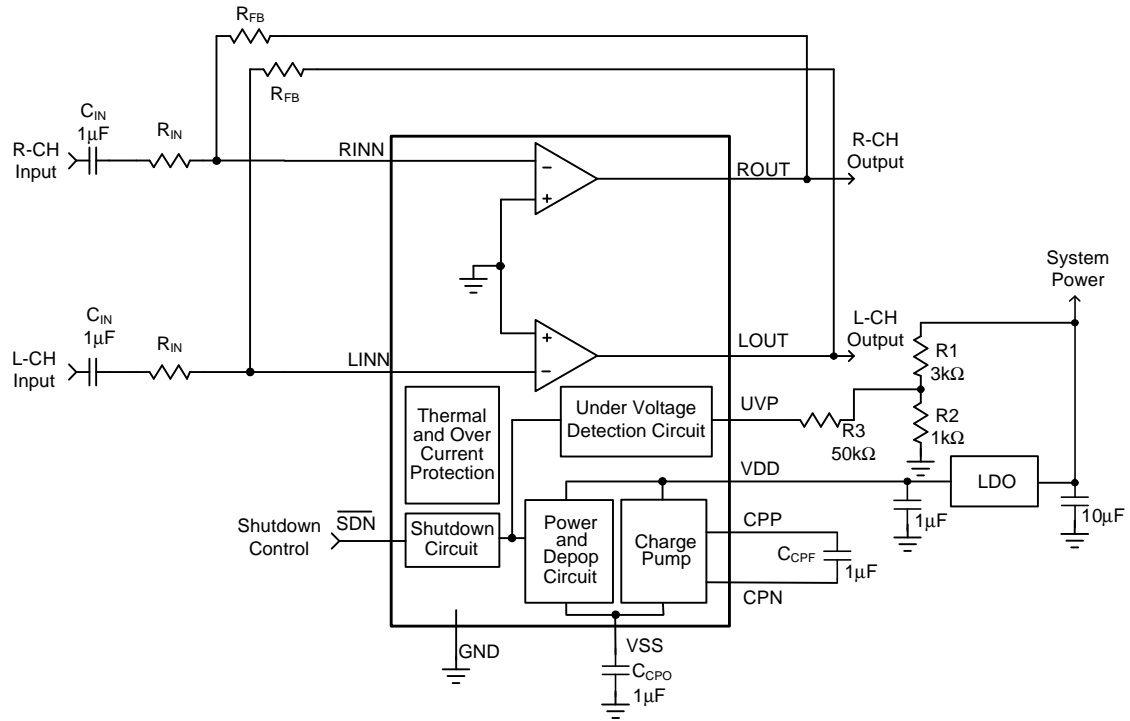

### Second-Order Active Low-Pass Filter

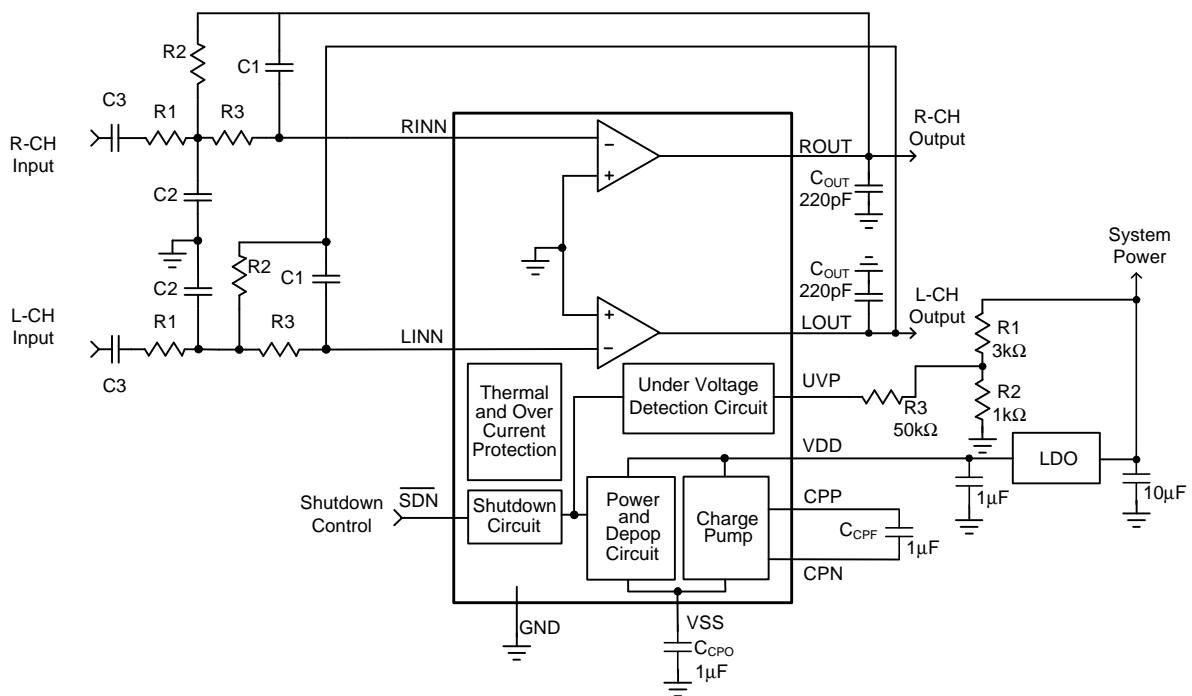

## Function Description

### Line Driver Operation

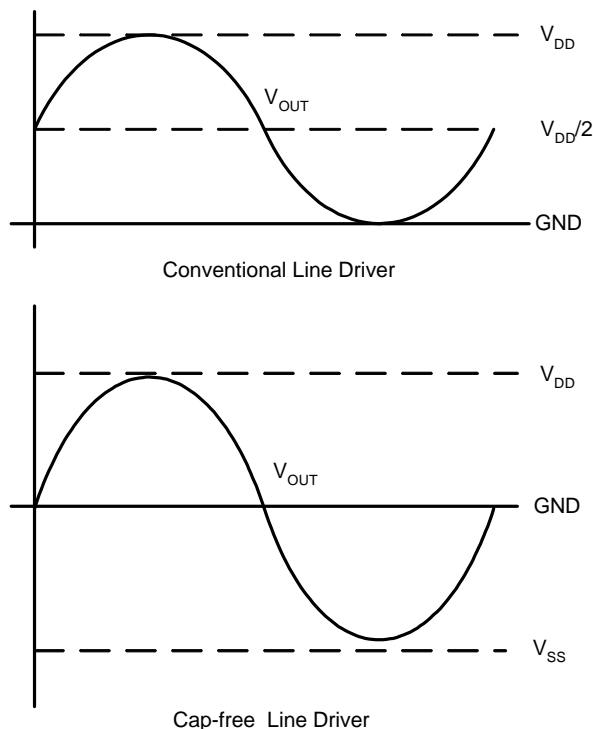

Figure 1. Cap-free Operation

The APA2173’s line drivers use a charge pump to invert the positive power supply ( $V_{DD}$ ) to negative power supply ( $V_{SS}$ ), see figure1. The headphone drivers operate at this bipolar power supply ( $V_{DD}$  and  $V_{SS}$ ) and the outputs reference refers to the ground. This feature eliminates the output capacitor that is using in conventional single-ended headphone drive amplifier. Compare with the single power supply amplifier, the power supply range has almost doubled.

### Thermal Protection

The thermal protection circuit limits the junction temperature of the APA2173. When the junction temperature exceeds  $T_J=+150^{\circ}\text{C}$ , a thermal sensor turns off the driver, allowing the devices to cool. The thermal sensor allows the driver to start-up after the junction temperature down about  $125^{\circ}\text{C}$ . The thermal protection is designed with a  $25^{\circ}\text{C}$  hysteresis to lower the average  $T_J$  during continuous thermal overload conditions, increasing lifetime of the ICs.

### Shutdown Function

In order to reduce power consumption while not in use, the APA2173 contains shutdown controllers to externally turn off the amplifier bias circuitry. This shutdown feature turns the amplifier off when logic low is placed on the  $\overline{\text{SDN}}$  pins for the APA2173. The trigger point between a logic high is 1.0V and logic low level is 0.35V. It is recommended to switch between ground and the supply voltage  $V_{DD}$  to provide maximum device performance. By switching the  $\overline{\text{SDN}}$  pins to a low level, the amplifier enters a low-consumption current circumstance, charge pump is disabled, and  $I_{DD}$  for the APA2173 is in shutdown mode. In normal operating, the APA2173’s  $\overline{\text{SDN}}$  pins should be pulled to a high level to keep the IC out of the shutdown mode. The  $\overline{\text{SDN}}$  pins should be tied to a definite voltage to avoid unwanted circumstance changes.

### Under-Voltage Protection

External under voltage detection can be used to shutdown the APA2173 before an input device can generate a pop. The shutdown threshold at the UVP pin is 1.25V. The user selects a resistor divider to obtain the shutdown threshold and hysteresis for the specific application. The thresholds can be determined as below:

$$V_{UVP} = (1.25 - 6\mu\text{A} \times R_3) \times (R_1 + R_2) / R_2$$

$$\text{Hysteresis} = 5\mu\text{A} \times R_3 \times (R_1 + R_2) / R_2$$

With the condition:  $R_3 \gg R_1 // R_2$

For example, to obtain  $V_{UVP}=3.8\text{V}$  and 1V hysteresis,  $R_1=3\text{k}\Omega$ ,  $R_2=1\text{k}\Omega$  and  $R_3=50\text{k}\Omega$ .

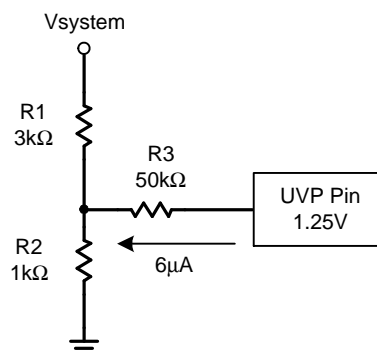

Figure 2. Under-Voltage Protection

## Application Information

### Using The APA2173 As A Second-Order Filter

Several audio DACs used today require an external low-pass filter to remove out-of-band noise. This is possible with the APA2173, as it can be used like a standard Operational Amplifier. Several filter topologies can be implemented, both single-ended and differential. In Figure 3, a multi-feedback (MFB) with differential input and single-ended input is shown.

An ac-coupling capacitor to remove dc content from the source is shown; it serves to block any dc content from the source and lowers the dc-gain to 1, helping reducing the output dc-offset to minimum.

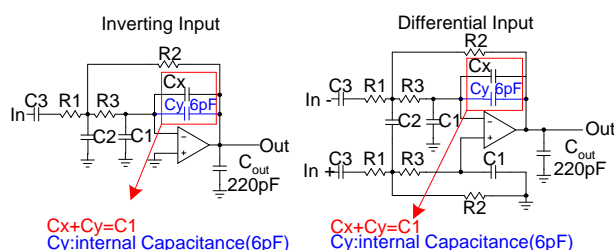

Figure 3. Second-Order Active Low-Pass Filter

Table 1: Filter Specifications.

Gain (V/V)	High Pass (Hz)	Low Pass (kHz)	C1 (pF)	C2 (pF)	C3 (mF)	R1 (kW)	R2 (kW)	R3 (kW)
-1	1.6	40	100	680	10	10	10	24
-1.5	1.3	40	68	680	15	8.2	12	30
-2	1.6	60	33	150	6.8	15	30	47
-2	1.6	30	47	470	6.8	15	30	43
-3.33	1.2	30	33	470	10	13	43	43
-10	1.5	30	22	1000	22	4.7	47	27

For Inverting Input, The overall gain is:

$$A_v = -\frac{R_2}{R_1} \tag{1}$$

The high pass filter's cutoff frequency is:

$$f_{c(\text{highpass})} = \frac{1}{2\pi R_1 C_3} \tag{2}$$

The low pass filter's cutoff frequency is:

$$f_{c(\text{lowpass})} = \frac{1}{2\pi\sqrt{R_2 R_3 C_1 C_2}} \tag{3}$$

### Input Capacitor, C<sub>i</sub>

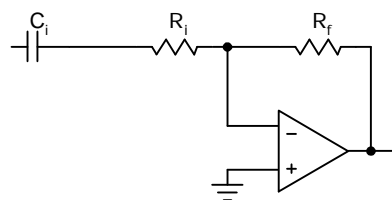

Figure 4. Typical Application Circuit

In the typical application, an input capacitor, C<sub>i</sub>, is required to allow the amplifier to bias the input signal to the proper DC level for optimum operation. In this case, C<sub>i</sub> and the minimum input impedance R<sub>i</sub> from a high-pass filter with the corner frequency are determined in the following equation:

$$f_{c(\text{highpass})} = \frac{1}{2\pi R_i C_i} \tag{4}$$

The value of C<sub>i</sub> must be considered carefully because it directly affects the low frequency performance of the circuit. R<sub>i</sub> is the external input resistance that typical value is 10kΩ and the specification calls for a flat bass response down to 20Hz. Equation is reconfigured as below:

$$C_i = \frac{1}{2\pi R_i f_{c(\text{highpass})}} \tag{5}$$

When the input resistance variation is considered, the C<sub>i</sub> is 0.8μF, so a value in the range of 1μF to 2.2μF would be chosen. A further consideration for this capacitor is the leakage path from the input source through the input network (R<sub>i</sub> + R<sub>f</sub>, C<sub>i</sub>) to the load.

This leakage current creates a DC offset voltage at the input to the amplifier that reduces useful headroom, especially in high gain applications. For this reason, a low leakage tantalum or ceramic capacitor is the best choice. When polarized capacitors are used, the negative side of the capacitor should face the amplifiers' input in most applications because the DC level of the amplifiers' input is held at GND. Please note that it is important to confirm the capacitor polarity in the application.

### Input Resistor, R<sub>i</sub>

The gain of the APA2173 is be set by the external input resistor (R<sub>i</sub>) and external feedback resistor (R<sub>f</sub>). Please see the figure 4.

## Application Information (Cont.)

### Input Resistor, $R_i$ (Cont.)

$$\text{Gain } (A_V) = \frac{R_f}{R_i} \quad (6)$$

The external gain setting is recommended using from  $-1V/V$  to  $-10V/V$ , and the  $R_i$  is in the range from  $1k\Omega$  to  $47k\Omega$ . It's recommended to use 1% tolerance resistor or better. Keep the input trace as short as possible to limit the noise injection.

The gain is recommended to set  $-1V/V$ , and  $R_i$  is  $10k\Omega$ , and  $R_f$  is  $10k\Omega$ .

### Feedback Resistor, $R_f$

Refer the figure 4, the external gain is setting by  $R_i$  and  $R_f$ ; and the gain setting is recommended using from  $-1V/V$  to  $-10V/V$ . The  $R_f$  is in the range from  $4.7k\Omega$  to  $100k\Omega$ . It's recommended to use 1% tolerance resistor or better.

### Power Supply Decoupling, $C_s$

The APA2173 is a high-performance CMOS audio amplifier that requires adequate power supply decoupling to ensure the output total harmonic distortion (THD+N) is as low as possible. Power supply decoupling also prevents the oscillations being caused by long lead length between the amplifier and the speaker.

The optimum decoupling is achieved by using two different types of capacitors that target on different types of noise on the power supply leads. For higher frequency transients, spikes, or digital hash on the line, a good low equivalent-series-resistance (ESR) ceramic capacitor, typically  $0.1\mu F$ , is placed as close as possible to the device VDD and PVDD lead for the best performance. For filtering lower frequency noise signals, a large aluminum electrolytic capacitor of  $10\mu F$  or greater placed near the audio power amplifier is recommended.

### Charge Pump Flying Capacitor, $C_{CPF}$

The flying capacitor affects the load transient of the charge pump. If the capacitor's value is too small, then that will degrade the charge pump's current driver capability and the performance of line drive amplifier.

Increasing the flying capacitor's value will improve the load transient of charge pump. It is recommended using the low ESR ceramic capacitors (X7R type is recommended) above  $1\mu F$ .

### Charge Pump Output Capacitor, $C_{CPO}$

The output capacitor's value affects the power ripple directly at  $CV_{SS}$  ( $V_{SS}$ ). Increasing the value of output capacitor reduces the power ripple. The ESR of output capacitor affects the load transient of  $CV_{SS}$  ( $V_{SS}$ ). Lower ESR and greater than  $1\mu F$  ceramic capacitor is a recommendation.

Package Information

MSOP-10P

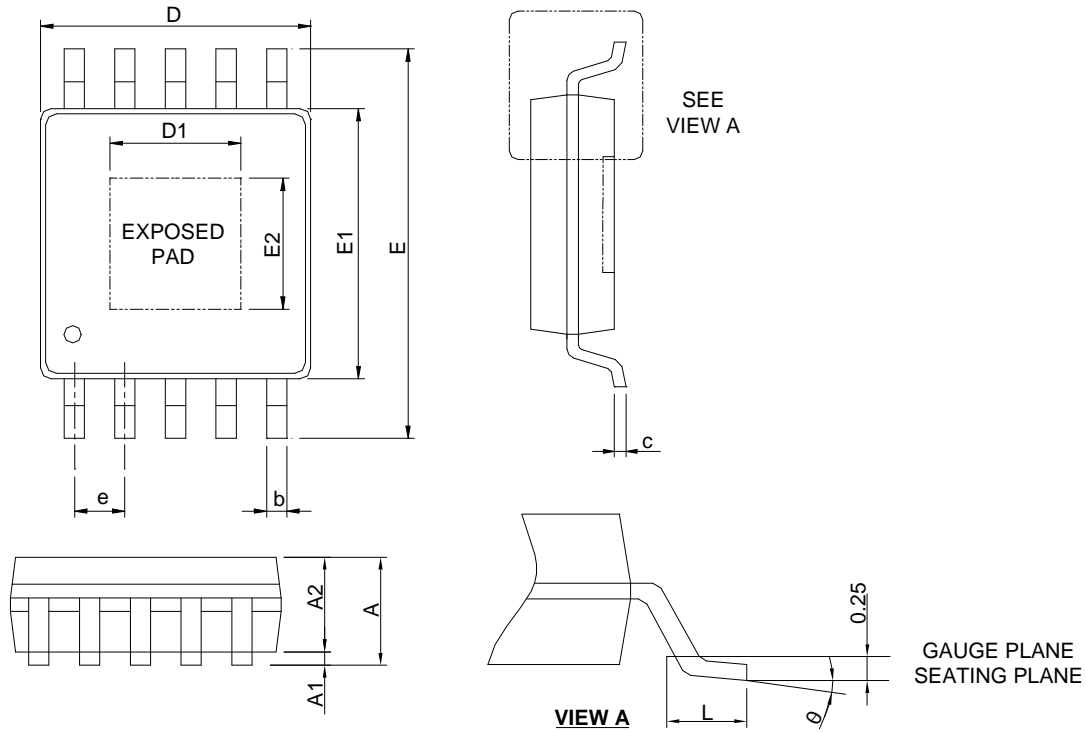

SYMBOL	MSOP-10P			
	MILLIMETERS		INCHES	
	MIN.	MAX.	MIN.	MAX.
A		1.10		0.043
A1	0.00	0.15	0.000	0.006
A2	0.75	0.95	0.030	0.037
b	0.17	0.33	0.007	0.013
c	0.08	0.23	0.003	0.009
D	2.90	3.10	0.114	0.122
D1	1.50	2.50	0.059	0.098
E	4.70	5.10	0.185	0.201
E1	2.90	3.10	0.114	0.122
E2	1.50	2.50	0.059	0.098
e	0.50 BSC		0.020 BSC	
L	0.40	0.80	0.016	0.031
$\theta$	0°	8°	0°	8°

- Note: 1. Follow JEDEC MO-187 BA-T.  
 2. Dimension " D " does not include mold flash, protrusions or gate burrs. Mold flash, protrusion or gate burrs shall not flash or protrusions.  
 3. Dimension " E1 " does not include inter-lead flash or protrusions. Inter-lead flash and protrusions shall not exceed 6 mil per side.

### Carrier Tape & Reel Dimensions

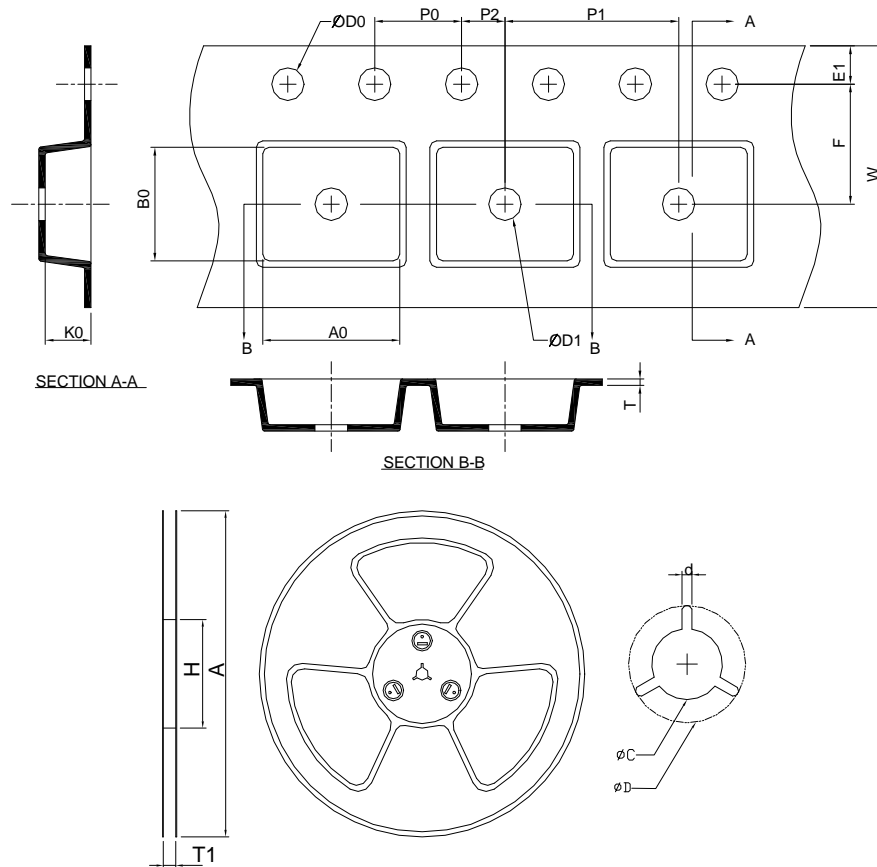

Application	A	H	T1	C	d	D	W	E1	F
MSOP-10P	330.0 ±2.00	50 MIN.	12.4+2.00 -0.00	13.0+0.50 -0.20	1.5 MIN.	20.2 MIN.	12.0 ±0.30	1.75 ±0.10	5.5 ±0.05
	P0	P1	P2	D0	D1	T	A0	B0	K0
	4.00 ±0.10	8.00 ±0.10	2.00 ±0.05	1.5+0.10 -0.00	1.5 MIN.	0.6+0.00 -0.40	5.30 ±0.20	3.30 ±0.20	1.40 ±0.20

(mm)

### Devices Per Unit

Package Type	Unit	Quantity
MSOP-10P	Tape & Reel	3000

# Taping Direction Information

MSOP-10P

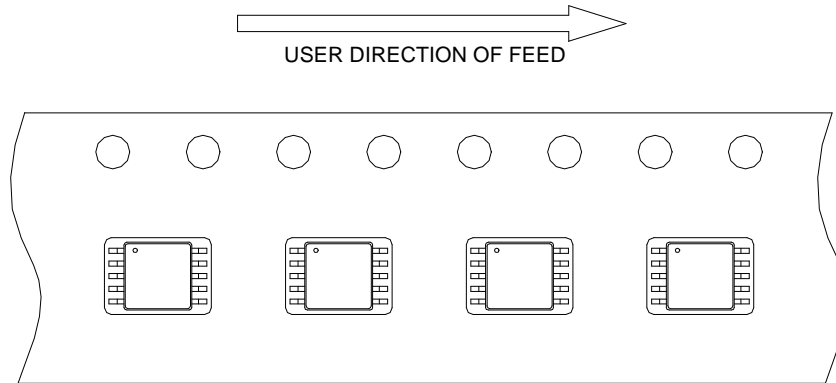

## Classification Profile

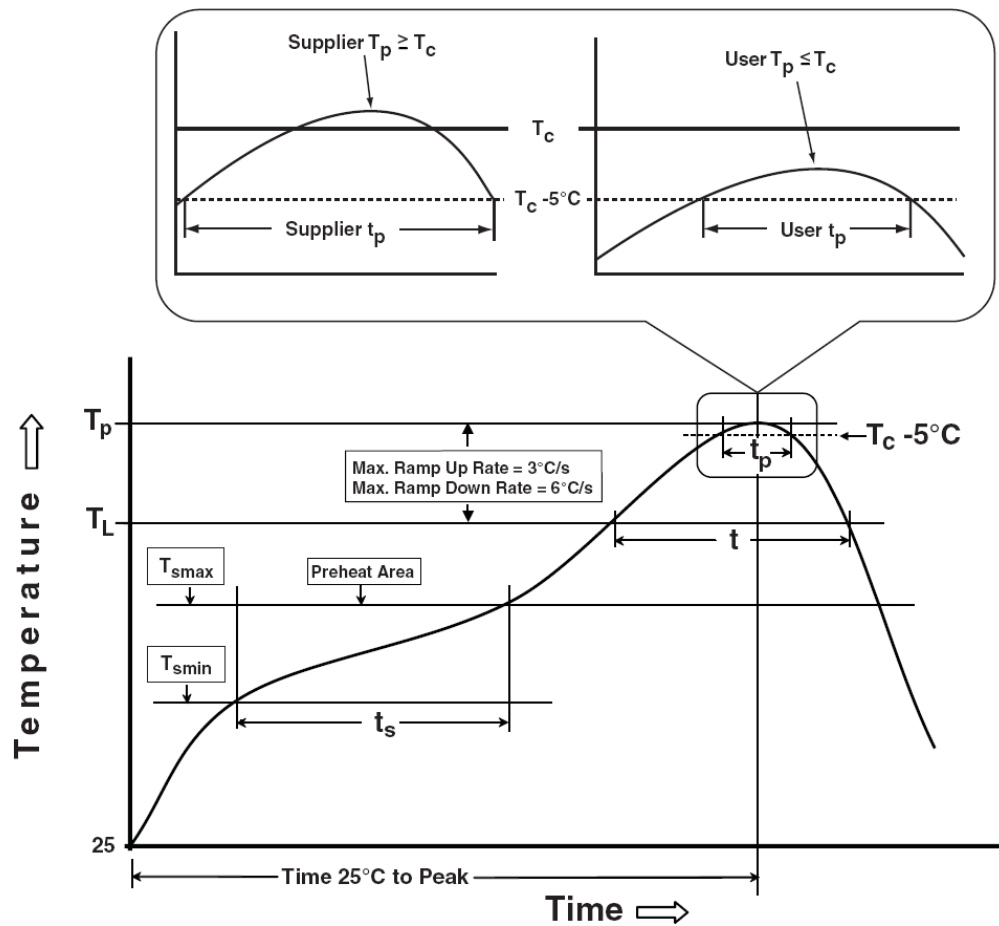



## Classification Reflow Profiles

Profile Feature	Sn-Pb Eutectic Assembly	Pb-Free Assembly
<b>Preheat &amp; Soak</b>		
Temperature min ( $T_{smin}$ )	100 °C	150 °C
Temperature max ( $T_{smax}$ )	150 °C	200 °C
Time ( $T_{smin}$ to $T_{smax}$ ) ( $t_s$ )	60-120 seconds	60-120 seconds
Average ramp-up rate ( $T_{smax}$ to $T_p$ )	3 °C/second max.	3 °C/second max.
Liquidous temperature ( $T_L$ )	183 °C	217 °C
Time at liquidous ( $t_L$ )	60-150 seconds	60-150 seconds
Peak package body Temperature ( $T_p$ )*	See Classification Temp in table 1	See Classification Temp in table 2
Time ( $t_p$ )** within 5°C of the specified classification temperature ( $T_c$ )	20** seconds	30** seconds
Average ramp-down rate ( $T_p$ to $T_{smax}$ )	6 °C/second max.	6 °C/second max.
Time 25°C to peak temperature	6 minutes max.	8 minutes max.
* Tolerance for peak profile Temperature ( $T_p$ ) is defined as a supplier minimum and a user maximum.		
** Tolerance for time at peak profile temperature ( $t_p$ ) is defined as a supplier minimum and a user maximum.		

Table 1. SnPb Eutectic Process – Classification Temperatures ( $T_c$ )

Package Thickness	Volume mm <sup>3</sup> <350	Volume mm <sup>3</sup> ≥350
<2.5 mm	235 °C	220 °C
≥2.5 mm	220 °C	220 °C

Table 2. Pb-free Process – Classification Temperatures ( $T_c$ )

Package Thickness	Volume mm <sup>3</sup> <350	Volume mm <sup>3</sup> 350-2000	Volume mm <sup>3</sup> >2000
<1.6 mm	260 °C	260 °C	260 °C
1.6 mm – 2.5 mm	260 °C	250 °C	245 °C
≥2.5 mm	250 °C	245 °C	245 °C

## Reliability Test Program

Test item	Method	Description
SOLDERABILITY	JESD-22, B102	5 Sec, 245°C
HOLT	JESD-22, A108	1000 Hrs, Bias @ $T_j=125^\circ\text{C}$
PCT	JESD-22, A102	168 Hrs, 100%RH, 2atm, 121°C
TCT	JESD-22, A104	500 Cycles, -65°C~150°C
HBM	MIL-STD-883-3015.7	VHBM 2KV
MM	JESD-22, A115	VMM 200V
Latch-Up	JESD 78	10ms, 1 <sub>tr</sub> 100mA

## Customer Service

**Anpec Electronics Corp.**

Head Office :

No.6, Dusing 1st Road, SBIP,  
Hsin-Chu, Taiwan  
Tel : 886-3-5642000  
Fax : 886-3-5642050

Taipei Branch :

2F, No. 11, Lane 218, Sec 2 Jhongsing Rd.,  
Sindian City, Taipei County 23146, Taiwan  
Tel : 886-2-2910-3838  
Fax : 886-2-2917-3838