

Rail to Rail Output CMOS Single Operating Amplifier

Features

- **Operating Voltage Single Supply, 3V to 6V**
- **Low Input Current, 2pA**
- **Rail to Rail Output Swing**
- **Push-Pull Output Driving**
- **High Output Current Drive, 310mA**
- **Bandwidth:7MHz**
- **Wide Temperature Range**
- **Available in the SOT-23-5 Package**
- **Single Version of APC308**
- **Lead Free and Green Devices Available (RoHS Compliant)**

General Description

The APC206/207/208 brings performance and economy with high gain, CMOS operating amplifier, combining rail to rail output range with large output current. It provides a low input bias current 2pA.

The output swing of the amplifier, guaranteed for loads down to 1kΩ and output current to an 10Ω load from a 5V power supply. APC206/207/208 designed to operate at 3V is especially well-suited for low voltage application. The APC206/207/208 is offered in the space saving SOT-23-5 package.

Applications

- **Amplifiers**
- **Filters**
- **Analog Circuit**

Ordering and Marking Information

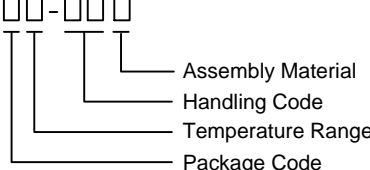
<p>APC206/207/208 □□-□□□</p>  <p style="margin-left: 150px;"> Assembly Material Handling Code Temperature Range Package Code </p>	<p>Package Code B : SOT-23-5 Temperature Range I : - 40 to 85 °C Handling Code TR : Tape & Reel Assembly Material G : Halogen and Lead Free Device</p>
<p>APC206/207/208 B : 206 X 207 X 208 X</p>	<p style="text-align: center;">X - Date Code</p>

Note: ANPEC lead-free products contain molding compounds/die attach materials and 100% matte tin plate termination finish; which are fully compliant with RoHS. ANPEC lead-free products meet or exceed the lead-free requirements of IPC/JEDEC J-STD-020D for MSL classification at lead-free peak reflow temperature. ANPEC defines "Green" to mean lead-free (RoHS compliant) and halogen free (Br or Cl does not exceed 900ppm by weight in homogeneous material and total of Br and Cl does not exceed 1500ppm by weight).

ANPEC reserves the right to make changes to improve reliability or manufacturability without notice, and advise customers to obtain the latest version of relevant information to verify before placing orders.

Absolute Maximum Ratings (Note 1)

Symbol	Parameter	Rating	Unit
V _{DD}	Supply Voltage	7	V
T _{SC(O)}	Output Short-Circuit Duration, at T _A =25°C, P _{TOT} =1W	20	S
T _A	Operating Ambient Temperature range	-40 to 85	°C
T _J	Maximum Junction Temperature	150	°C
T _{STG}	Storage Temperature Range	-65 to +150	°C
T _S	Maximum Lead Soldering Temperature, 10 Seconds	260	°C

Note 1: Absolute Maximum Ratings are those values beyond which the life of a device may be impaired. Exposure to absolute maximum rating conditions for extended periods may affect device reliability.

Thermal Characteristics

Symbol	Parameter	Typical Value	Unit
θ _{JA}	Thermal Resistance from Junction to Ambient in Free Air ^(Note 2) SOT-23-5	357	°C/W

Note 2: θ_{JA} is measured with the component mounted on a high effective thermal conductivity test board in free air.

Electrical Characteristics

V_{DD}=5V, T_A=25°C (unless otherwise noted)

Symbol	Parameter	Test Conditions	APC206/207/208			Unit
			Min.	Typ.	Max.	
V _{OS}	Input Offset Voltage	T _A =25°C	-	4	10	mV
		-25°C < T _A < 75°C	-	5	-	mV
I _{BIAS}	Input Bias Current	T _A =25°C	-	2	-	pA
V _{ICM}	Input Common Mode Voltage Range	T _A =25°C	0	-	V _{DD} -0.8	V
R _{IN}	Input Resistance		-	5	-	mΩ
V _O	Output Voltage Swing	R _L =2kΩ	0	-	5	V
V _{OH}	Output Voltage High	R _L =10kΩ, -25°C < T _A < 75°C	-	5	-	V
V _{OL}	Output Voltage Low	R _L =10kΩ, -25°C < T _A < 75°C	-	0	-	V
I _{OUT}	Output Current Source	V _O =4.5V	-	-310	-	mA
	Output Current Sink	V _O =0.5V	-	370	-	mA
CMRR	Common Mode Rejection Ratio		-	-80	-	dB
PSRR	Supply Voltage Rejection Ratio	V _{RR} =100mV _{PP} , f _{in} =100Hz, R _L =2kΩ	-	-50	-	dB
A _V	Large Signal Voltage Gain		-	85	-	dB
GBW	Gain Bandwidth Product		-	7	-	MHz
SR	Slew Rate		-	5.6	-	V/μs
I _{CC}	Supply Current	-25°C < T _A < 75°C	-	2.0	4	mA
		2.4V < V _{CC} < 6V, T _A =25°C	-	2.5	5	mA

Typical Operating Characteristics

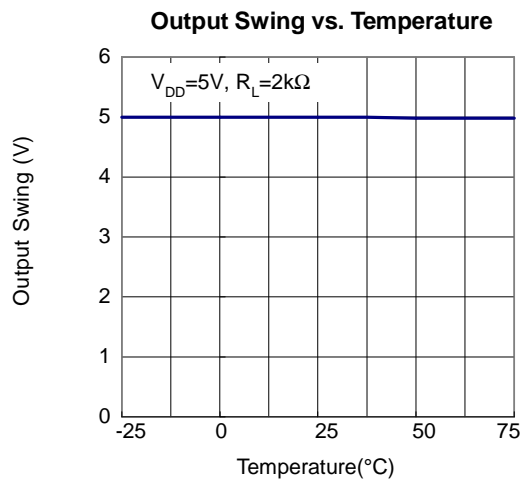
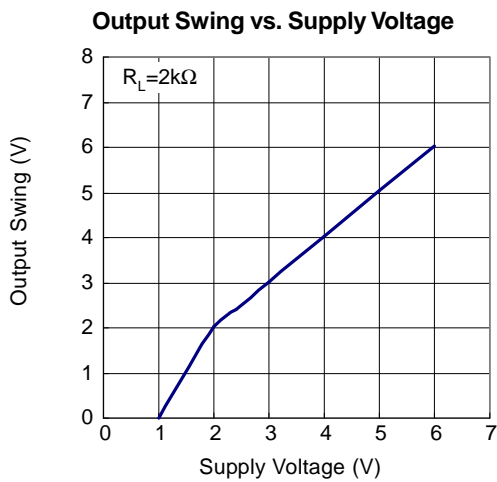
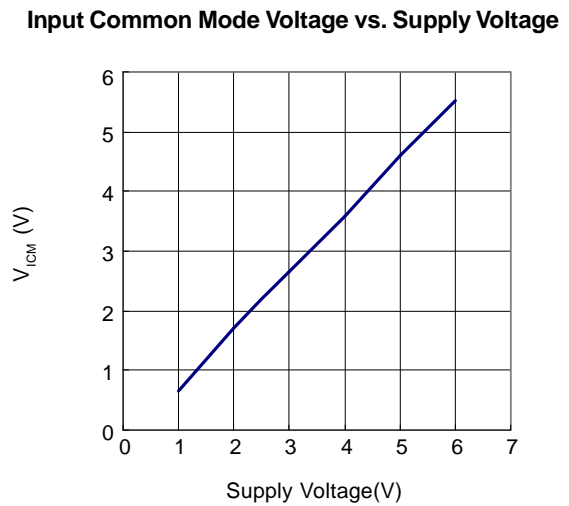
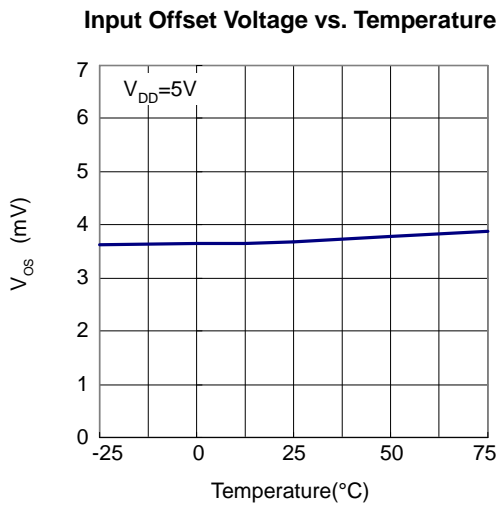
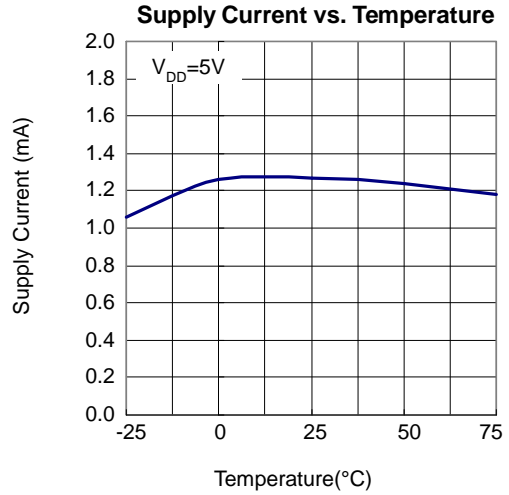
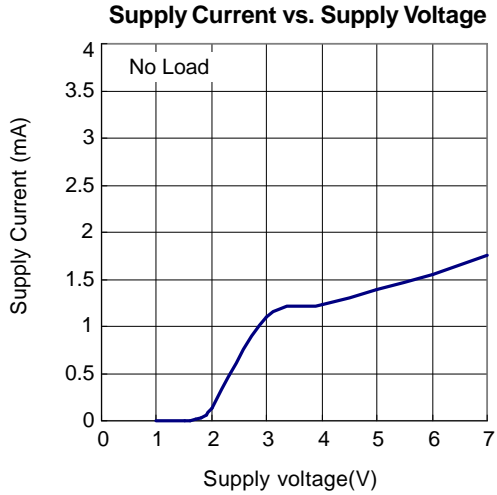

Typical Operating Characteristics (Cont.)

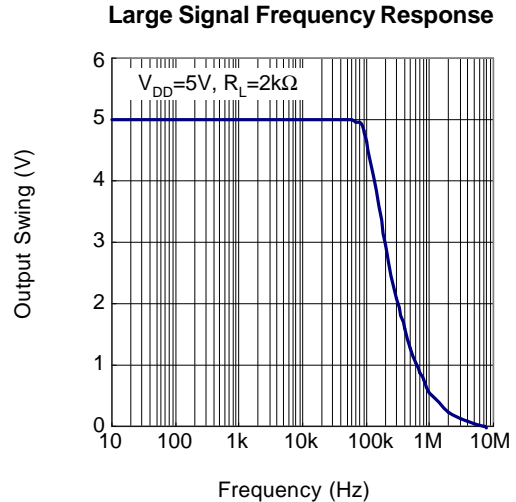
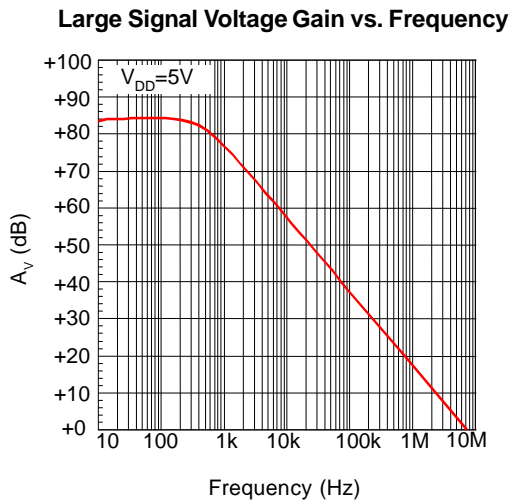
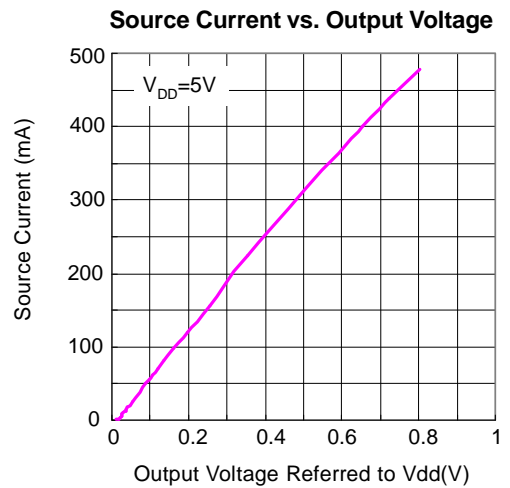
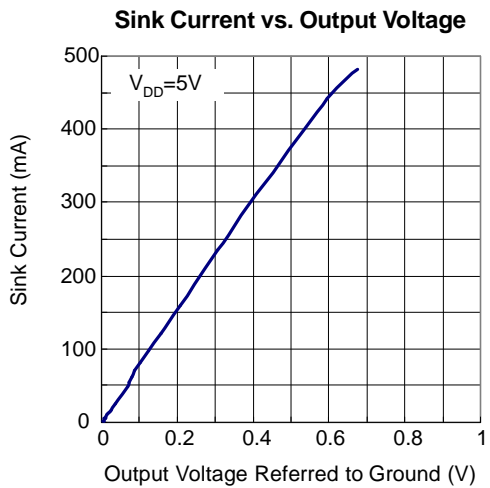
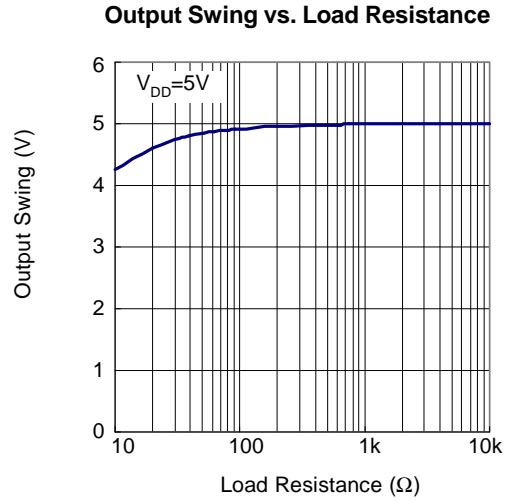
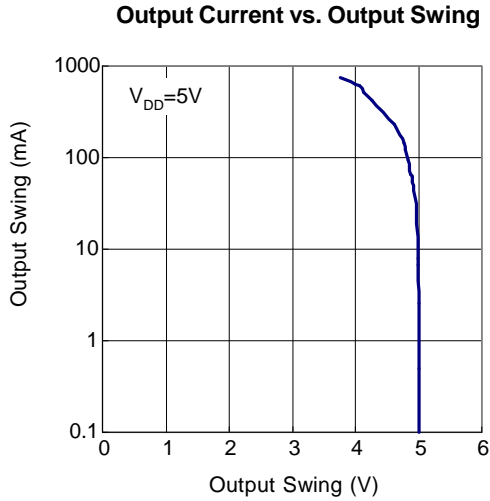

Typical Operating Characteristics (Cont.)

Large Signal Voltage Gain vs. Supply Voltage

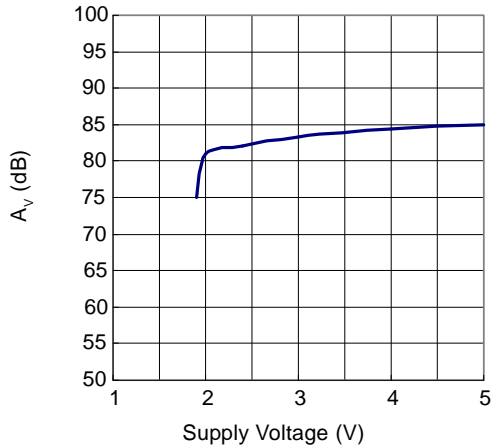

CMRR vs. Frequency

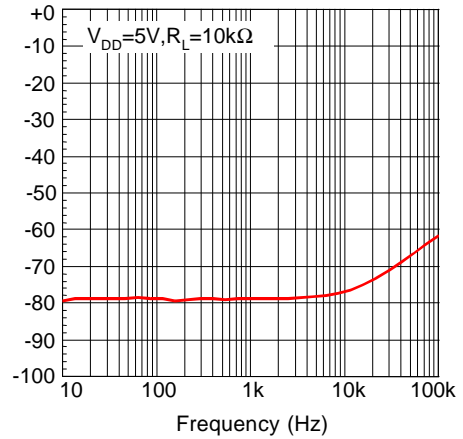

PSRR vs. Frequency

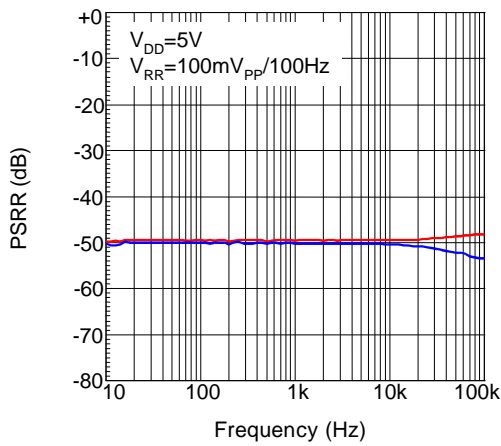

Voltage Follower Pulse Response

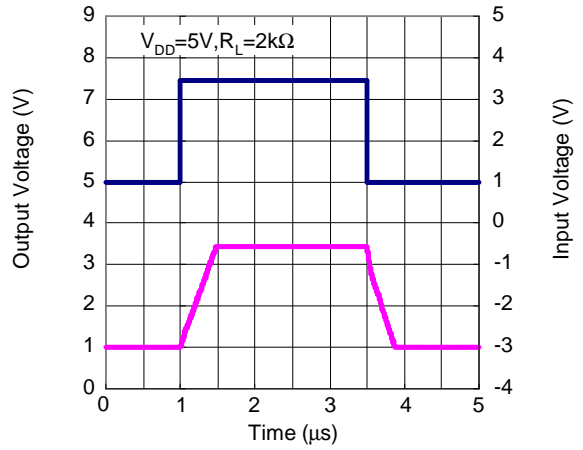

Voltage Follower Pulse Response

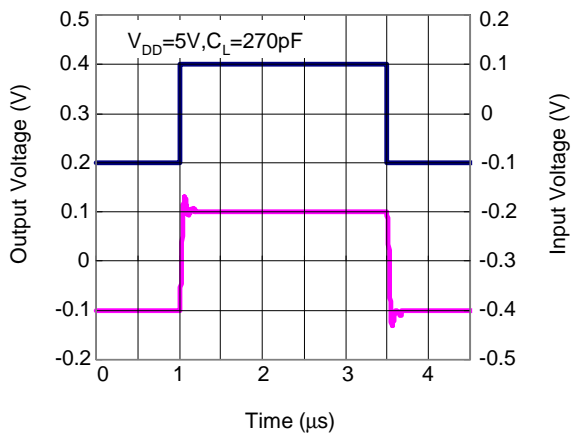

Block Diagram

APC206

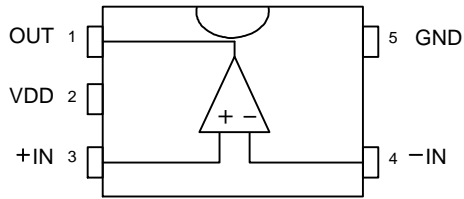

SOT-23-5
(Top View)

APC207

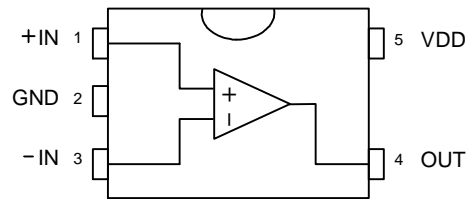

SOT-23-5
(Top View)

APC208

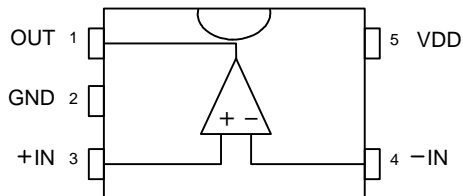

SOT-23-5
(Top View)

Package Information

SOT-23-5

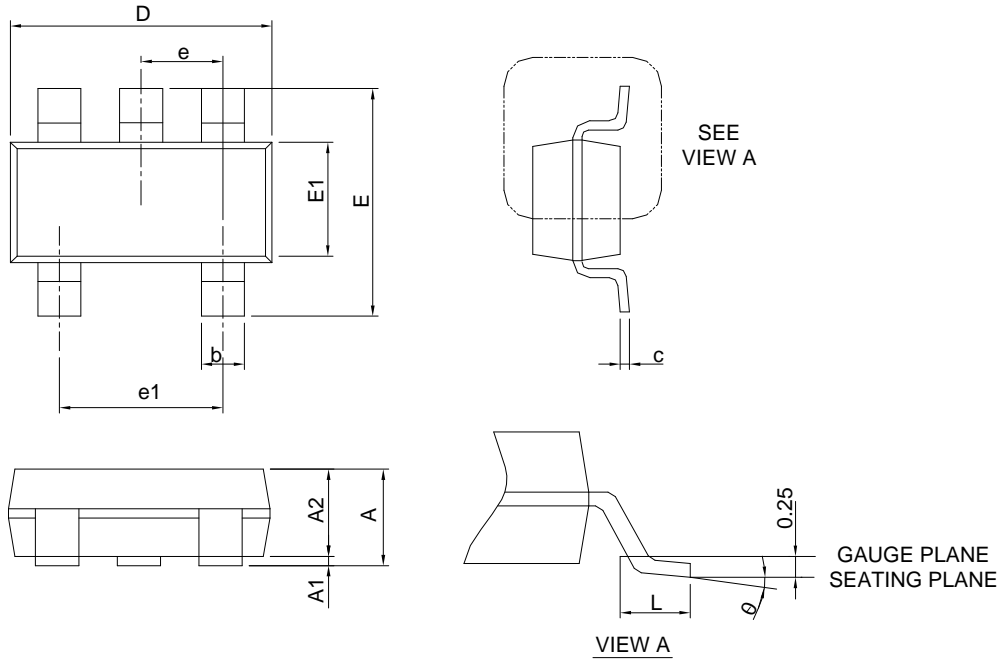

SYMBOL	SOT-23-5			
	MILLIMETERS		INCHES	
	MIN.	MAX.	MIN.	MAX.
A		1.45		0.057
A1	0.00	0.15	0.000	0.006
A2	0.90	1.30	0.035	0.051
b	0.30	0.50	0.012	0.020
c	0.08	0.22	0.003	0.009
D	2.70	3.10	0.106	0.122
E	2.60	3.00	0.102	0.118
E1	1.40	1.80	0.055	0.071
e	0.95 BSC		0.037 BSC	
e1	1.90 BSC		0.075 BSC	
L	0.30	0.60	0.012	0.024
θ	0°	8°	0°	8°

Note : 1. Follow JEDEC TO-178 AA.
 2. Dimension D and E1 do not include mold flash, protrusions or gate burrs. Mold flash, protrusion or gate burrs shall not exceed 10 mil per side.

Carrier Tape & Reel Dimensions

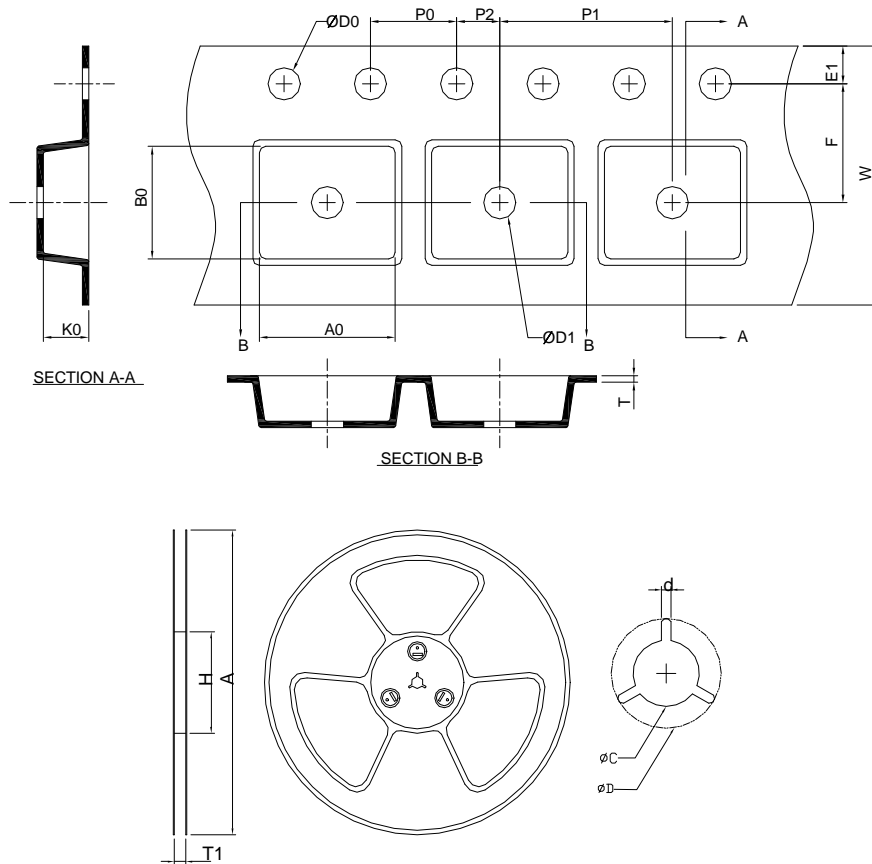

Application	A	H	T1	C	d	D	W	E1	F
SOT-23-5	178.0 ±0.00	50 MIN.	8.4+2.00 -0.00	13.0+0.50 -0.20	1.5 MIN.	20.2 MIN.	8.0 ±0.30	1.75 ±0.10	3.5 ±0.05
	P0	P1	P2	D0	D1	T	A0	B0	K0
	4.0 ±0.10	4.0 ±0.10	2.0 ±0.05	1.5+0.10 -0.00	1.0 MIN.	0.6+0.00 -0.40	3.20 ±0.20	3.10 ±0.20	1.50 ±0.20

(mm)

Devices Per Unit

Package Type	Unit	Quantity
SOT-23-5	Tape & Reel	3000

Taping Direction Information

SOT-23-5

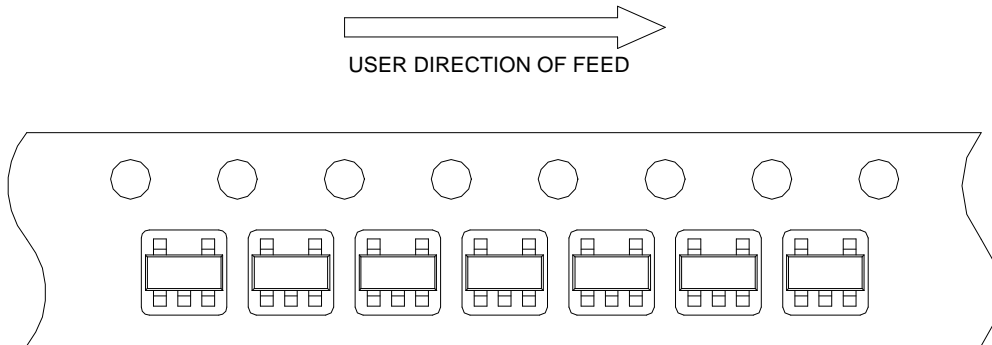

Classification Profile

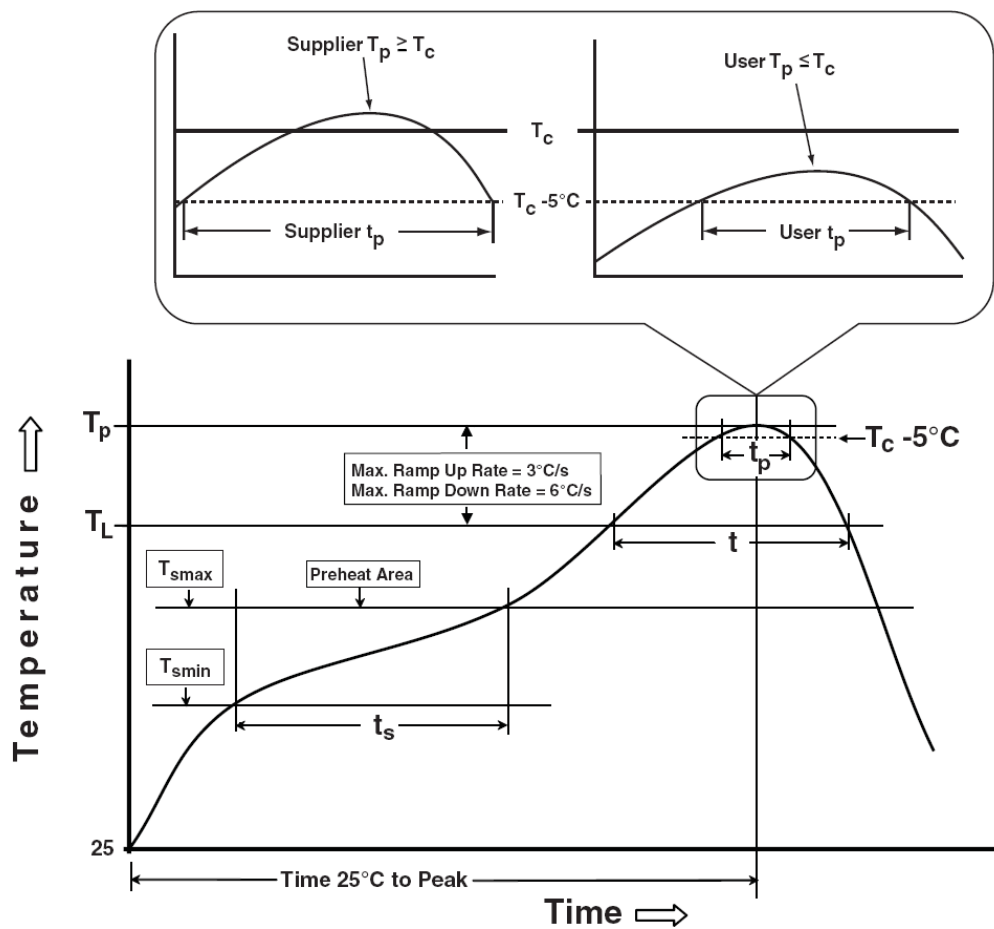

Classification Reflow Profiles

Profile Feature	Sn-Pb Eutectic Assembly	Pb-Free Assembly
Preheat & Soak		
Temperature min (T_{smin})	100 °C	150 °C
Temperature max (T_{smax})	150 °C	200 °C
Time (T_{smin} to T_{smax}) (t_s)	60-120 seconds	60-120 seconds
Average ramp-up rate (T_{smax} to T_p)	3 °C/second max.	3°C/second max.
Liquidous temperature (T_L)	183 °C	217 °C
Time at liquidous (t_L)	60-150 seconds	60-150 seconds
Peak package body Temperature (T_p)*	See Classification Temp in table 1	See Classification Temp in table 2
Time (t_p)** within 5°C of the specified classification temperature (T_c)	20** seconds	30** seconds
Average ramp-down rate (T_p to T_{smax})	6 °C/second max.	6 °C/second max.
Time 25°C to peak temperature	6 minutes max.	8 minutes max.
* Tolerance for peak profile Temperature (T_p) is defined as a supplier minimum and a user maximum.		
** Tolerance for time at peak profile temperature (t_p) is defined as a supplier minimum and a user maximum.		

Table 1. SnPb Eutectic Process – Classification Temperatures (T_c)

Package Thickness	Volume mm ³ <350	Volume mm ³ ≥350
<2.5 mm	235 °C	220 °C
≥2.5 mm	220 °C	220 °C

Table 2. Pb-free Process – Classification Temperatures (T_c)

Package Thickness	Volume mm ³ <350	Volume mm ³ 350-2000	Volume mm ³ >2000
<1.6 mm	260 °C	260 °C	260 °C
1.6 mm – 2.5 mm	260 °C	250 °C	245 °C
≥2.5 mm	250 °C	245 °C	245 °C

Reliability Test Program

Test item	Method	Description
SOLDERABILITY	JESD-22, B102	5 Sec, 245°C
HOLT	JESD-22, A108	1000 Hrs, Bias @ $T_j=125^\circ\text{C}$
PCT	JESD-22, A102	168 Hrs, 100%RH, 2atm, 121°C
TCT	JESD-22, A104	500 Cycles, -65°C~150°C
HBM	MIL-STD-883-3015.7	VHBM 2KV
MM	JESD-22, A115	VMM 200V
Latch-Up	JESD 78	10ms, 1 _{tr} 100mA

Customer Service

Anpec Electronics Corp.

Head Office :

No.6, Dusing 1st Road, SBIP,

Hsin-Chu, Taiwan, R.O.C.

Tel : 886-3-5642000

Fax : 886-3-5642050

Taipei Branch :

2F, No. 11, Lane 218, Sec 2 Jhongsing Rd.,

Sindian City, Taipei County 23146, Taiwan

Tel : 886-2-2910-3838

Fax : 886-2-2917-3838