



1.9A FIXED FREQUENCY WHITE LED DRIVER

FEATURES

- 2.5V to 5.5 V Operating Input Voltage Rang
- Drives up to 8 Series White LEDs
- 1.2MHz Fixed Switching Frequency
- Wide Range for PWM Dimming (200Hz to 200KHz)
- Internal 1.9A Switching Current Limit
- Over Voltage Protection (OVP)
- Internal Soft-start Function
- Current Limit and Thermal Shutdown Protection
- Under Voltage Lockout
- Available in the TSOT-26 Packages

DESCRIPTION

The APE1612 is a step-up converter designed for driving up to 8 series white LEDs for backlighting application. The APE1612 uses current mode, 1.2MHz fixed frequency architecture to regulate the LED current, which is set through an external current sense resistor. Its low 300mV feedback voltage reduces power loss and improves efficiency. The OV pin monitors the output voltage and turns off the converter if an over-voltage condition is present due to an open circuit condition. The APE1612 includes under-voltage lockout, current limiting and thermal shutdown protection preventing damage in the event of an output overload. The driver is available in TSOT-26 packages.

TYPICAL APPLICATION

1. 8 series LED application

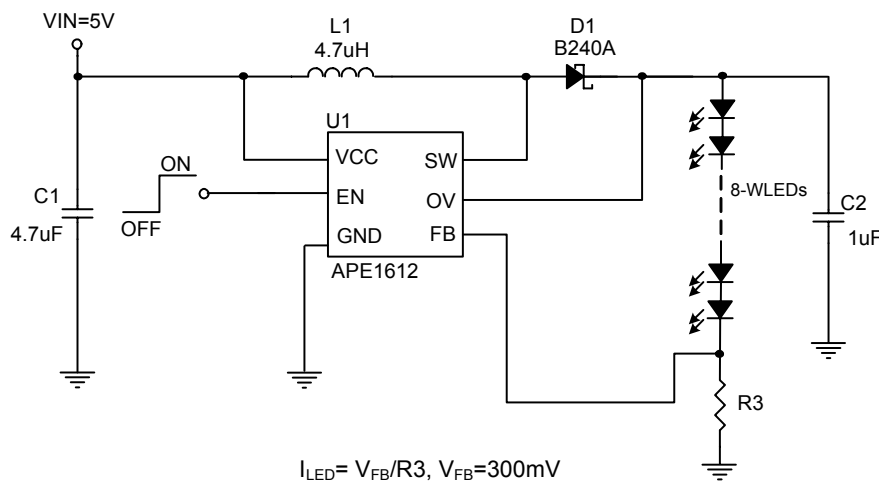

2. LED Dimming application

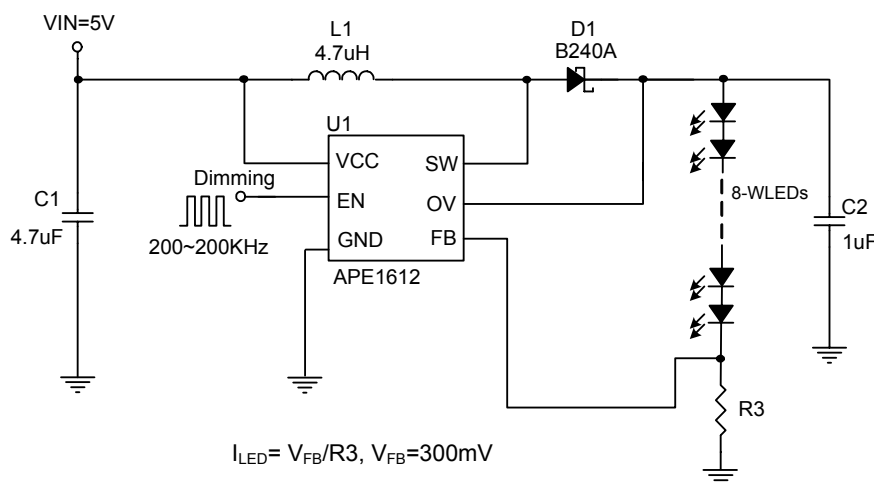

ABSOLUTE MAXIMUM RATINGS (at $T_A=25^{\circ}\text{C}$)

VCC Pin Voltage (V_{CC})	-----	GND - 0.3 to GND + 6V
EN, FB, OV Pin Voltage	-----	GND - 0.3 to VCC + 0.3V
SW Pin Voltage (V_{SW})	-----	30V
Power Dissipation(P_D)	-----	(T_J-T_A) / $R_{th_{ja}}$ mW
Storage Temperature Range(T_{ST})	-----	-65°C To 150°C
Operating Junction Temperature Range(T_{OP})	-----	-40°C To 125°C
Thermal Resistance from Junction to Case($R_{th_{JC}}$)		180°C/W
Thermal Resistance from Junction to Ambient($R_{th_{JA}}$)		250°C/W

Note: $R_{th_{JA}}$ is measured with the PCB copper area of approximately 1 in²(Multi-layer)

ORDERING / PACKAGE INFORMATION

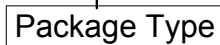
APE1612 X

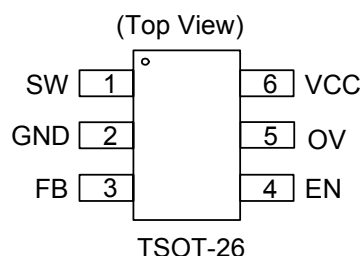
 TY : TSOT-26

ELECTRICAL SPECIFICATIONS ($V_{CC}=5\text{V}$, $I_{OUT} = 20\text{mA}$, $T_A = 25^{\circ}\text{C}$, unless otherwise noted)

Parameter	SYM	TEST CONDITION	MIN	TYP	MAX	UNITS
Input Voltage Range	V_{CC}		2.5	-	5.5	V
Step-Up Voltage Range	V_{OUT}		3	-	27	V
OV Sense Voltage	V_{OV}		27.5	29	30.5	V
Under Voltage Lockout	U_{VLO}	Rising	-	2.25	2.45	V
UVLO Hysteresis			-	100	-	mV
Feedback Voltage	V_{FB}		285	300	315	mV
EN Threshold	Logic-High Voltage	V_{IH}	1.4	-	-	V
	Logic-Low Voltage	V_{IL}	-	-	0.4	V
EN Hysteresis			-	200	-	mV
Operating Quiescent Current	I_{CCQ}	$I_{OUT}=0\text{mA}$, $V_{FB}=0.5\text{V}$	-	170	-	μA
Shutdown Current	I_{SD}	$V_{EN}=0\text{V}$, $t_{EN} > 20\text{ms}$	-	-	1	μA
N-Channel MOSFET Current Limit (Note1)	I_{LIM}	Duty=50%	-	1.9	-	A
MOSFET On-resistance (Note1)	$R_{DS(on)}$	$V_{CC}=3\text{V}$, $I_{SW}=1\text{A}$	-	650	-	m Ω
		$V_{CC}=5\text{V}$, $I_{SW}=1\text{A}$	-	500	-	
Maximum Duty Cycle	D_{MAX}		85	90	-	%
Line Regulation		$V_{CC} = 3\text{V to } 5\text{V}$	-	1	-	%
Switching Frequency	F_{OSC}		0.9	1.2	1.5	MHz
Dimming Clock Rate	F_{DIM}		0.2	-	200	KHz



ELECTRICAL SPECIFICATIONS

Parameter	SYM	TEST CONDITION	MIN	TYP	MAX	UNITS
FB Input Leakage Current	I_{FB-LKG}	$V_{FB} = 0.5V$	-	0.01	100	nA
SW Leakage Current	I_{SWL}	$V_{LX} = 27V, V_{FB} = 0.5V$	-	-	1	μA
EN Input Leakage Current	$I_{EN-LKG1}$	$V_{EN} = V_{CC}$	-	1.5	3	μA
	$I_{EN-LKG2}$	$V_{EN} = GND$	-	0.01	0.1	μA
Shutdown Delay	T_{SHDN}		-	10	-	mS
Thermal Shutdown	T_{SD}		-	150	-	$^{\circ}C$
Thermal Shutdown Hysteresis	T_{SH}		-	30	-	

Note1 : Guaranteed by design.

PIN DESCRIPTIONS

PIN SYMBOL	PIN DESCRIPTION
VCC	Power Input Pin
EN	Enable with dimming pin, Internal pull-high.
FB	Feedback Pin; Put a resistor to GND to setting the current
GND	Ground Pin
OV	OVP Sense Pin
SW	Switch Output Pin

BLOCK DIAGRAM

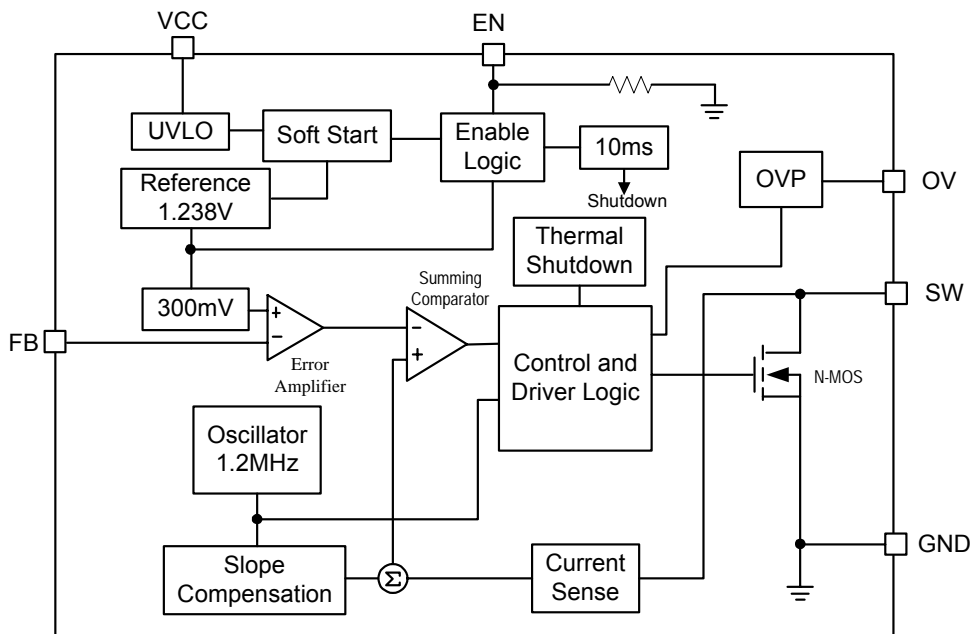

APPLICATION INFORMATION**Setting the ILED Current**

Application circuit item shows the basic application circuit with APE1612 adjustable output version. The external resistor sets the LED output current according to the following equation:

$$I_{LED} = \left(\frac{0.3V}{R3} \right)$$

I_{LED}	R3	
20mA	15Ω	6mW
350mA	0.857Ω	105mW

Over Voltage Protection

OV measure the output voltage for open circuit protection. Connect OV pin to the output at the top of the LED string. If V_{OUT} above 29V, the OVP protection is happened that stops the internal driver until V_{OUT} below 29V.

Under Voltage Lockout (UVLO)

To avoid mis-operation of the device at low input voltages an under voltage lockout is included that disables the device, if the input voltage falls below (2.25V-100mV).

Input Capacitor Selection

The input capacitor reduces the surge current drawn from the input and switching noise from the device. The input capacitor impedance at the switching frequency shall be less than input source impedance to prevent high frequency switching current passing to the input. A low ESR input capacitor sized for maximum RMS current must be used. Ceramic capacitors with X5R or X7R dielectrics are highly recommended because of their low ESR and small temperature coefficients. A 4.7 μ F ceramic capacitor for most applications is sufficient. For a lower output power requirement application, this value can be decreased.

Output Capacitor Selection

The output capacitor is required to keep the output voltage ripple small and to ensure regulation loop stability. The output capacitor must have low impedance at the switching frequency. Ceramic capacitors with X5R or X7R dielectrics are recommended due to their low ESR and high ripple current. A 1uF ceramic capacitors works for most of the applications. Higher capacitor values can be used to improve the load transient response.



TYPICAL PERFORMANCE CHARACTERISTICS

Efficiency vs. Output Current

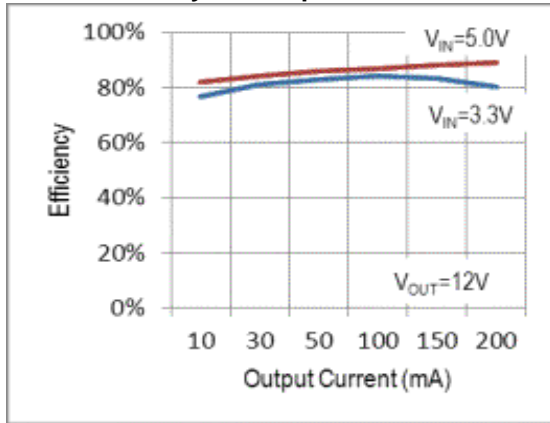

Efficiency vs. Input Voltage

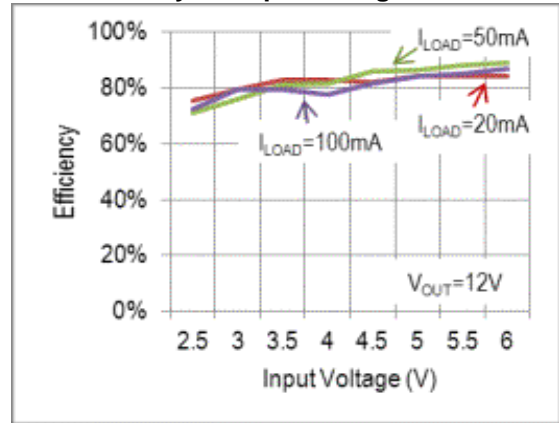

Output Voltage vs. Output Current

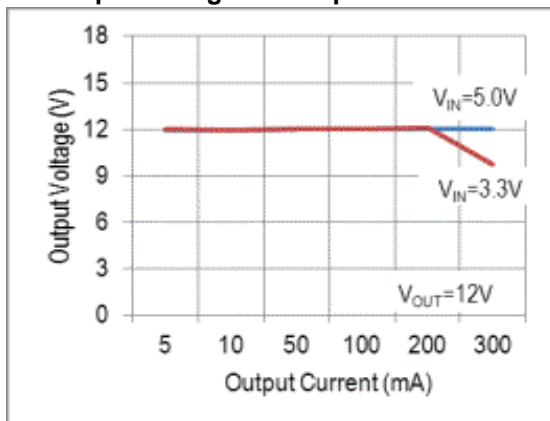

Quiescent Current vs. Input Voltage

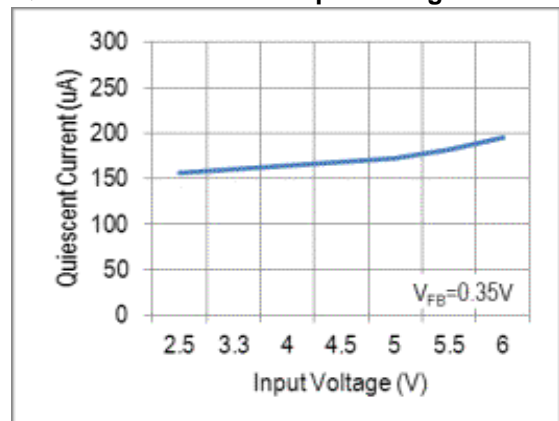

Frequency vs. Input Voltage

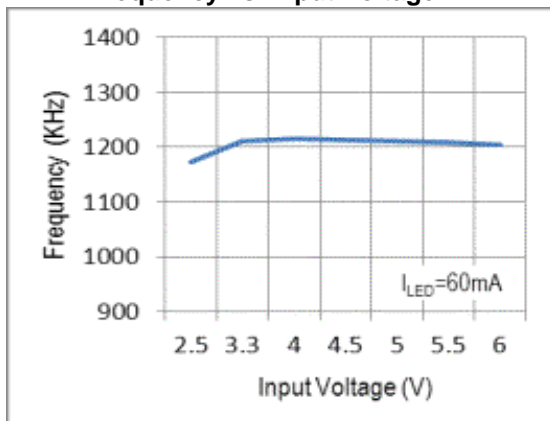

Frequency vs. Temperature

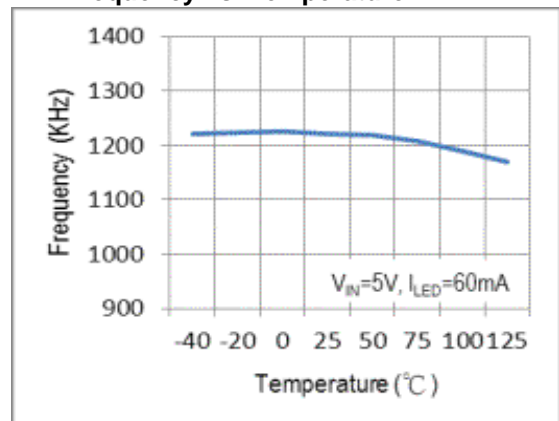



TYPICAL PERFORMANCE CHARACTERISTICS

Reference Voltage vs. Input Voltage

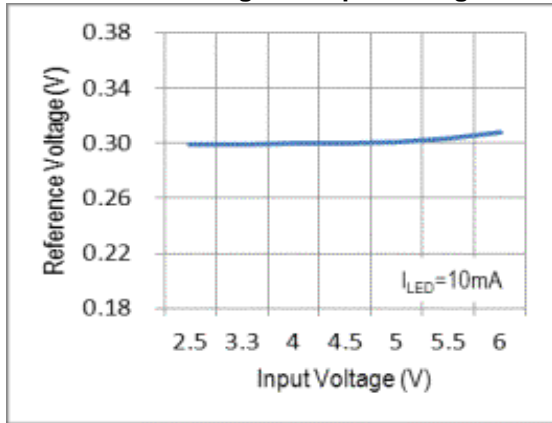

Reference Voltage vs. Temperature

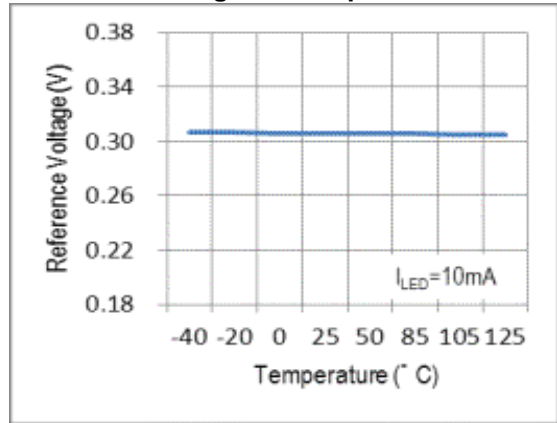

LED Current vs. Duty

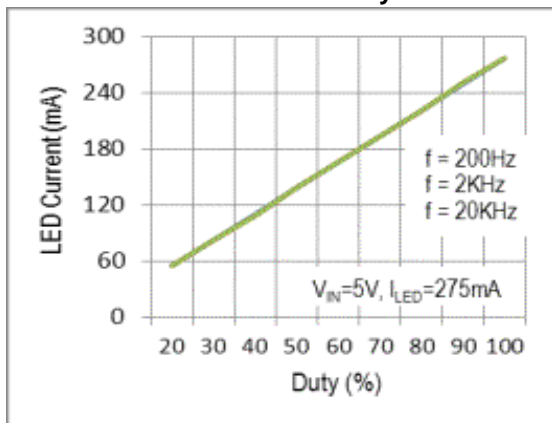

Enable Threshold vs. Input Voltage

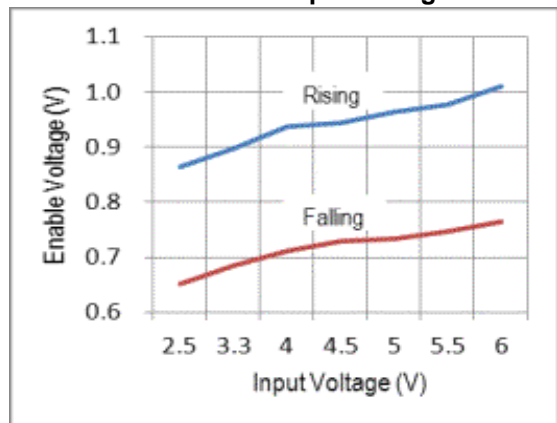

Power ON from VIN

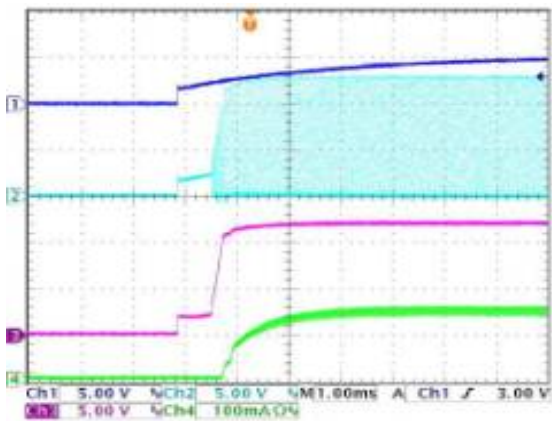

Power ON from EN

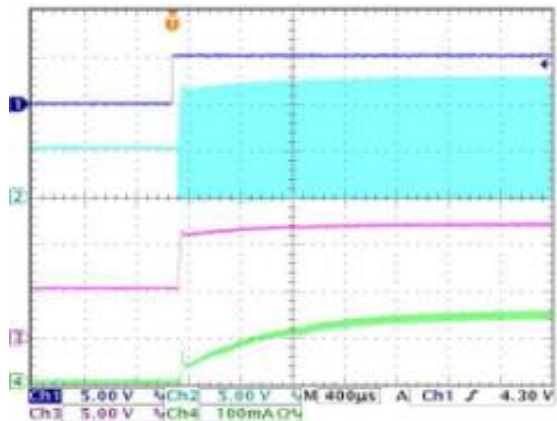



TYPICAL PERFORMANCE CHARACTERISTICS

Steady State Operation

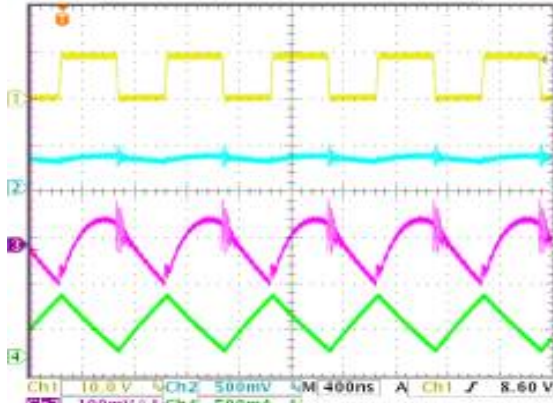

(V_{out} , I_{out} : measured by AC coupled mode)

Normal Operation into OVP

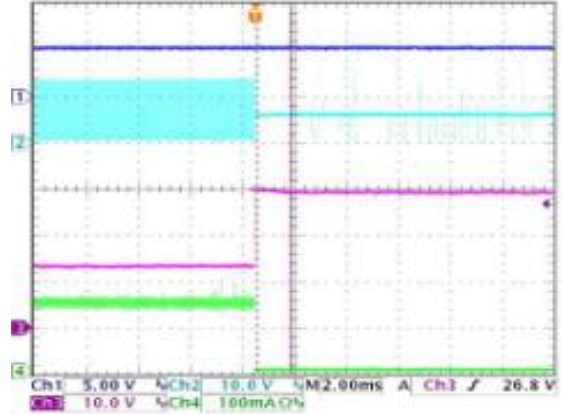

PWM Dimming from EN (200Hz)

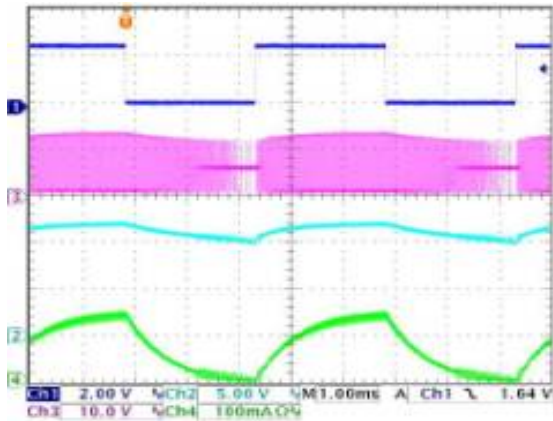

PWM Dimming from EN (20KHz)

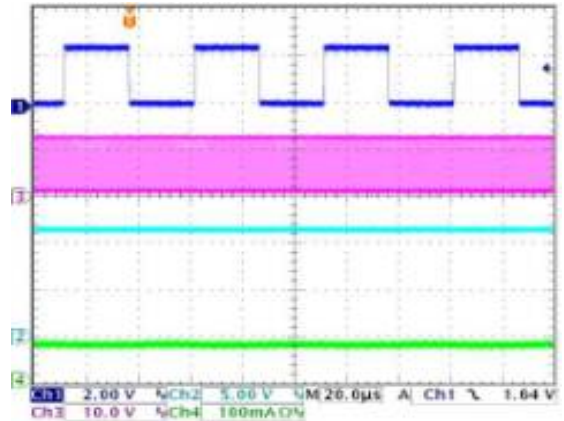



MARKING INFORMATION

TSOT-26

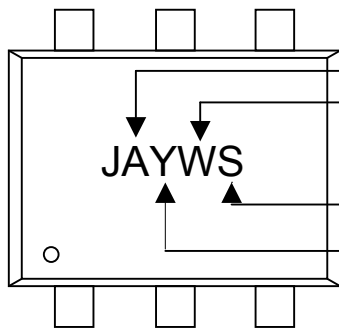

Part Number : JA
Week:
A~Z : 01~26
a~z : 27~52
ID Code : Internal
Year :
A = 2010
1 = 2011
:
:



PACKAGE OUTLINES

TSOT-26

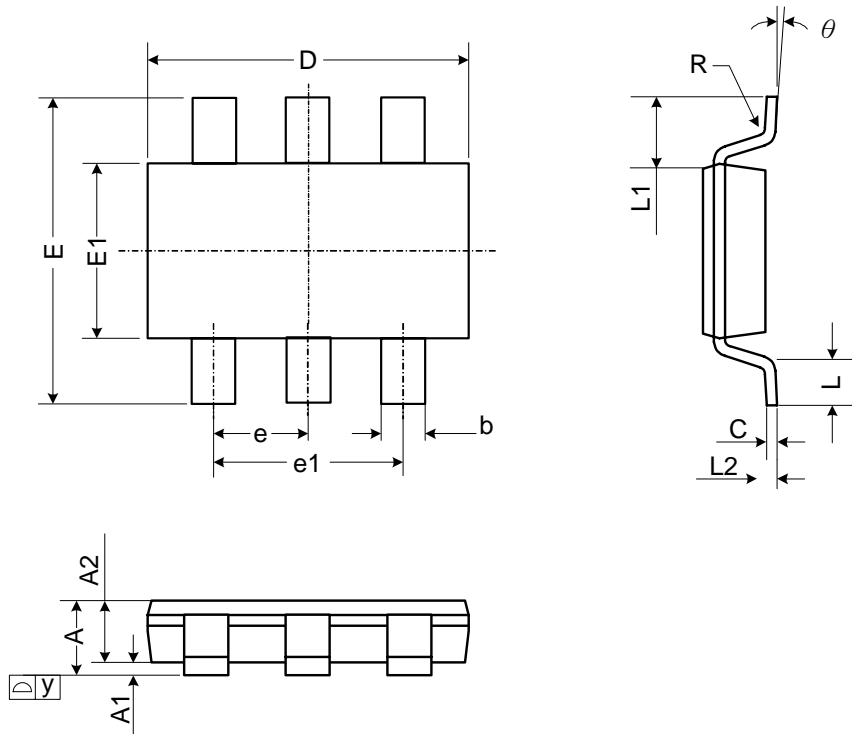

Symbol	Dimensions in Millimeters			Dimensions in Inches		
	Min.	Nom.	Max.	Min.	Nom.	Max.
A	-	-	1.10	-	-	0.043
A1	0.00	-	0.10	0	-	0.004
A2	0.70	0.90	1.00	0.028	0.035	0.039
b	0.30	0.40	0.50	0.012	0.016	0.020
C	0.08	0.14	0.20	0.003	0.006	0.008
D	2.80	2.90	3.00	0.110	0.114	0.118
E	2.60	2.80	3.00	0.102	0.110	0.118
E1	1.50	1.60	1.70	0.059	0.063	0.067
e	0.95 BSC.			0.037 BSC.		
e1	1.90 BSC.			0.075 BSC.		
L	0.30	0.45	0.60	0.012	0.018	0.024
L1	0.60 REF.			0.024 REF.		
L2	0.25 BSC.			0.010 BSC.		
y	-	-	0.10	-	-	0.004
R	0.10	-	-	0.004	-	-
θ	0°	-	8°	0°	-	8°

JEDEC outline: MO-193 AA