



## DUAL CHANNEL LDO REGULATORS WITH ENABLE

### FEATURES

- Input Voltage Range : 2.5V to 6V
- Varied Fixed Output Voltage Combinations
- 200mV Dropout at 200mA Output Current ( $V_{out} \geq 2.5V$ )
- Output Current: 200mA/channel (typ.)
- Low Quiescent Current : 60uA (typ.)
- Current Limit and Short Current Protection
- Thermal Shutdown Protection
- Fast Transient Response
- Low ESR Capacitor Compatible (X7R, X5R)
- Halogen Free Product

### DESCRIPTION

The APE8837 is a high accurately, low noise, high ripple rejection ratio, low dropout, dual CMOS LDO voltage regulators with enable function. The EN function allows the output of each regulator to be turned off independently, resulting in greatly reduced power consumption.

The APE8837 has the soft start function to suppress the inrush current. The current limit is over 250mA per channel and also operates as a short protection for the output current limiter. The output voltage for each regulator is set independently by metal trimming.

The APE8837 is fully compatible with low ESR ceramic capacitors, reducing cost and improving output stability. This high level output stability is maintained even during frequent load fluctuations, due to the excellent transient response performance and high PSRR achieved across a broad range of frequency. It is available in the SOT-26, TSOT-26 and DFN 2x2 packages.

### TYPICAL APPLICATION

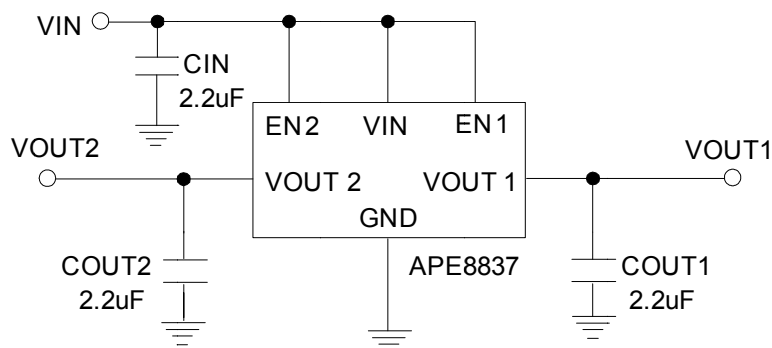



**ORDERING / PACKAGE INFORMATION**

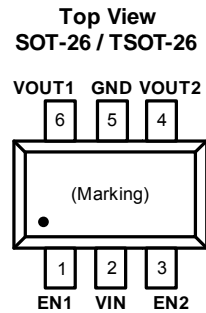
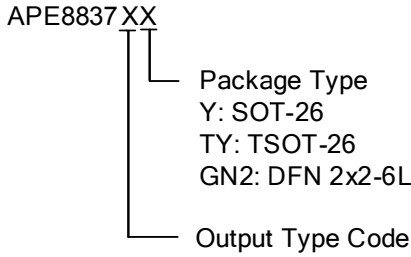

Output Type Code : (V <sub>OUT1</sub> +V <sub>OUT2</sub> )		
A : 1.5V+2.8V	J : 2.8+3.3V	S : 1.2V+1.8V
B : 1.8V+2.8V	K : 3.0+3.0V	T : 1.5V+3.3V
C : 1.8V+2.6V	L : 3.0V+3.3V	U : 2.5V+2.5V
D : 1.8V+3.3V	M : 3.3V+3.3V	V : 1.5V+3.0V
E : 2.5V+2.8V	N : 1.2V+3.3V	W : 1.2V+2.8V
F : 2.8V+1.2V	P : 1.8V+3.0V	X : 1.2V+1.2V
G : 2.8V+1.8V	Q : 1.5V+2.5V	Y : 2.8V+1.5V
H : 2.8+3.0V	R : 3.3V+1.8V	Z : 2.8V+2.8V

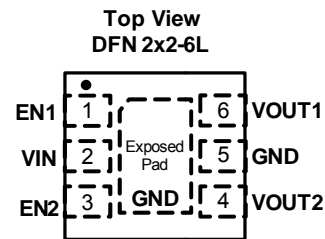

**ABSOLUTE MAXIMUM RATINGS** (at T<sub>A</sub>=25°C)

VIN	-0.3V to 6.5V
VOUT1, VOUT2	-0.3V to 6.5V
EN1, EN2	-0.3V to 6.5V
Output Current (I <sub>O1</sub> +I <sub>O2</sub> )	800mA
Junction Temperature (T <sub>J</sub> )	-40 to 125°C
Operating Temperature Range (T <sub>OP</sub> )	-40°C to 85°C
Storage Temperature Range (T <sub>ST</sub> )	-65 to +150°C
Lead Temperature (Soldering, 10sec.)	260°C
Thermal Resistance from Junction to Ambient (R <sub>θJA</sub> )	
SOT-26 / TSOT-26	250°C/W
DFN 2x2-6L	120°C/W
Thermal Resistance from Junction to Case (R <sub>θJC</sub> )	
SOT-26 / TSOT-26	180C/W
DFN 2x2-6L	25°C/W

Note: R<sub>θJA</sub> is measured with the PCB copper area of approximately 1 in<sup>2</sup> (Multi-layer) which connect to GND pin or exposed pad (DFN 2x2-6L).



**ELECTRICAL SPECIFICATIONS**

( $V_{IN}=5V$ ,  $T_A=25^{\circ}C$ , unless otherwise specified)

PARAMETER	SYM	TEST CONDITION	MIN	TYP	MAX	UNIT	
Input Voltage	$V_{IN}$	$I_{OUT}=10mA$	2.5		6	V	
Output Voltage Accuracy	$\Delta V_{OUT}$	$I_{OUT}=1mA$ , $V_{IN}=5V$ , $V_{OUT}>1.8V$	-2		2	%	
		$I_{OUT}=1mA$ , $V_{IN}=5V$ , $V_{OUT}\leq 1.8V$	-0.04		0.04	V	
Quiescent Current	$I_{CC}$	$I_{OUT1,2}=0mA$ , $V_{IN}=5V$		60	100	$\mu A$	
Dropout Voltage	$V_{DROP}$	$I_{OUT}=0.2A$ , $V_O=V_O-2\%$ , $V_{OUT}=1.2V$		1100	1500	mV	
		$I_{OUT}=0.2A$ , $V_O=V_O-2\%$ , $V_{OUT}=1.5V$		800	1200	mV	
		$I_{OUT}=0.2A$ , $V_O=V_O-2\%$ , $V_{OUT}=1.8V$		500	900	mV	
		$I_{OUT}=0.2A$ , $V_O=V_O-2\%$ , $V_{OUT}>2.5V$		200	400	mV	
Current Limit <sup>(Note1)</sup>	$I_{LIMIT}$	$V_{IN}=V_{OUT}+1.0V$ , $V_{EN}=V_{IN}$	250			mA	
Short Circuit Current	$I_{SC}$	Output Voltage $< 0.25xV_{OUT}$ , each channel		150		mA	
Line Regulation	$\Delta V_{LINE}$	$I_{OUT}=1mA$ , $V_{IN}=V_{OUT}+1V$ to 6.0V		0.2	0.3	%/V	
Load Regulation <sup>(Note 1)</sup>	$\Delta V_{LOAD}$	$I_{OUT}=1\sim 100mA$ , $V_{IN}=V_{OUT}+1V$		0.01	0.03	%/mA	
Ripple Rejection <sup>(Note2)</sup>	PSRR	$f=120Hz$ , $I_{OUT}=30mA$		60		dB	
Output Voltage Temperature Coefficient <sup>(Note2)</sup>	T.C.	$I_{OUT}=1mA$		$\pm 100$		ppm/ $^{\circ}C$	
Enable Input Threshold	$V_{ENH}$	$V_{IN}=5V$	1.7			V	
		$V_{IN}=3.3V$	1.4			V	
	$V_{ENL}$	$V_{IN}=5V$			1.2		V
		$V_{IN}=3.3V$			1.0		V
Enable Pull-high Current	$I_{EN1,2}$	$V_{EN1,2}=0V$	-	1	2	$\mu A$	
Shutdown Current	$I_{SD}$	$I_{OUT1,2}=0mA$ , $V_{IN}=5V$ , $V_{EN1,2}=0V$	-	2	4	$\mu A$	
Thermal Shutdown Threshold <sup>(Note2)</sup>	$T_{SD}$			150		$^{\circ}C$	
		Hysteresis		40		$^{\circ}C$	

Note1: It is measured at constant junction temperature by using pulsed testing with a low ON time.

Note2: Guarantee by design, not production tested.



### PIN DESCRIPTIONS

PIN No.	PIN SYMBOL	PIN DESCRIPTION
1	EN1	VOUT1 Enable Control Pin. Internal pull high.
2	VIN	Input Voltage.
3	EN2	VOUT2 Enable Control Pin. Internal pull high.
4	VOUT2	Output2 Voltage.
5	GND	Common Ground Pin.
6	VOUT1	Output1 Voltage.

### BLOCK DIAGRAM

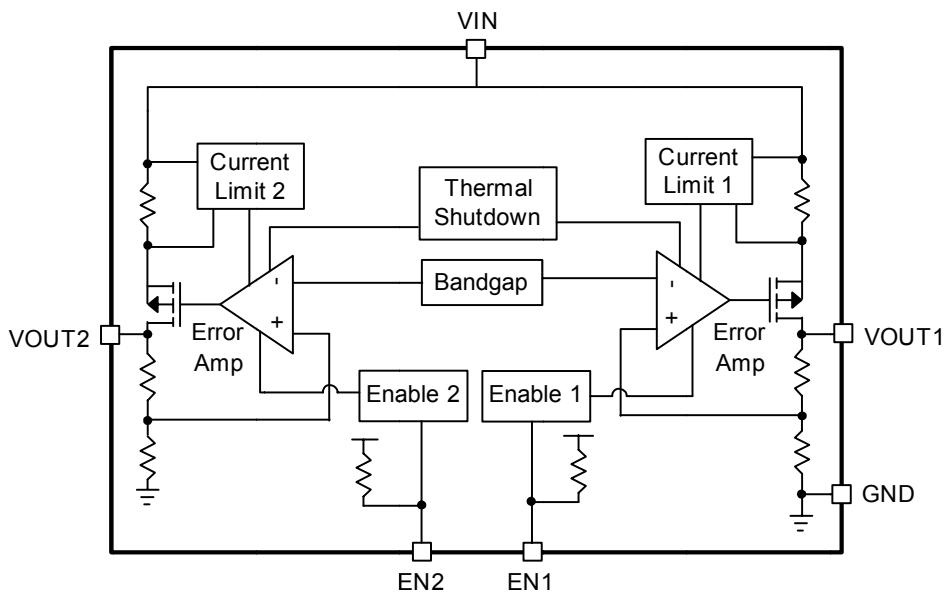



TYPICAL PERFORMANCE CHARACTERISTICS

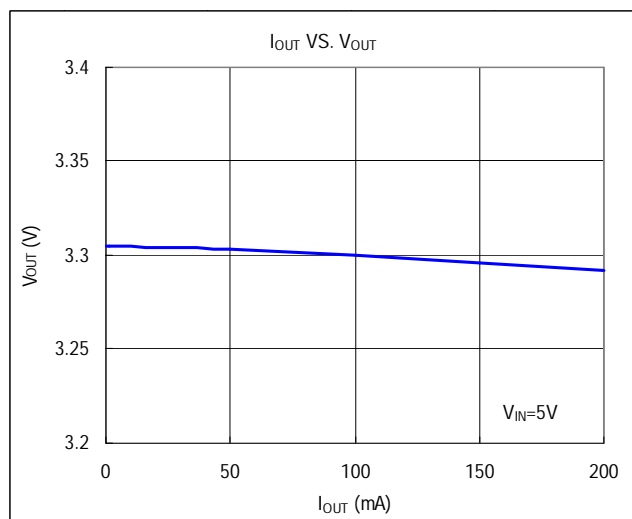
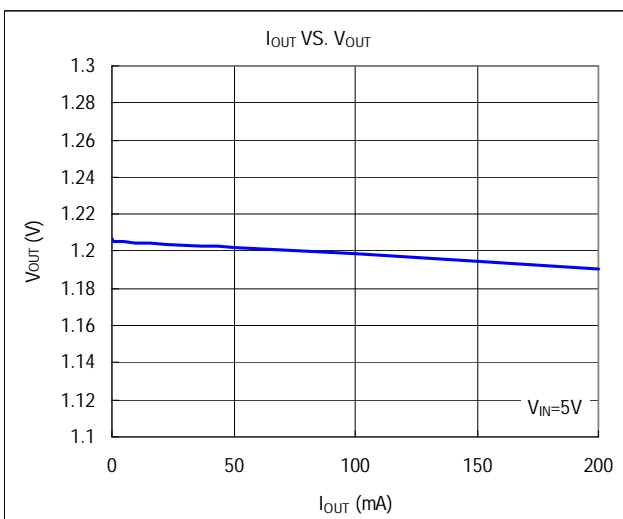
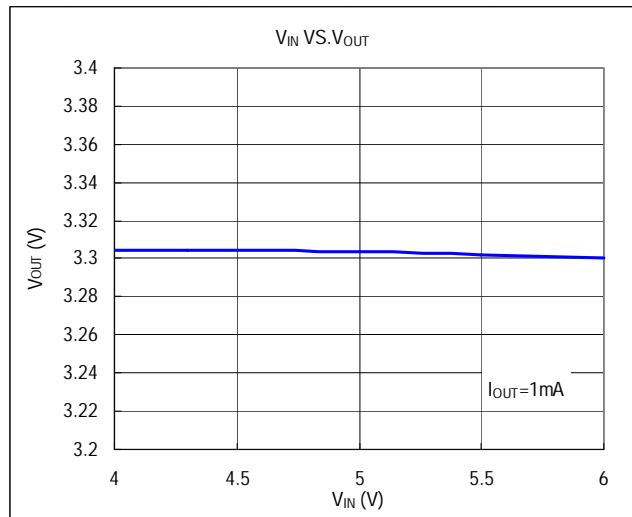
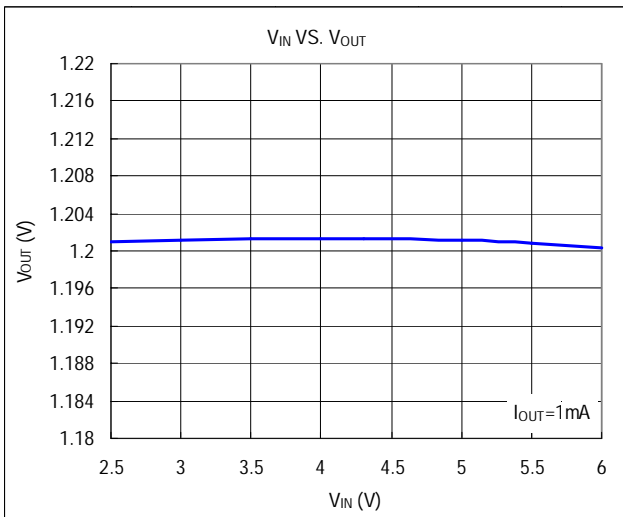
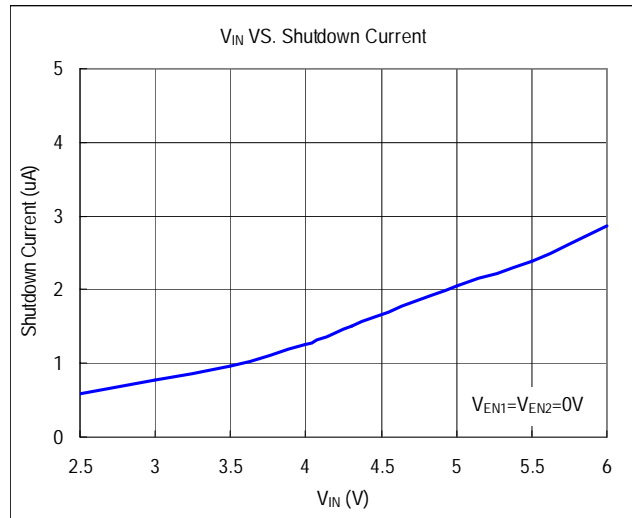
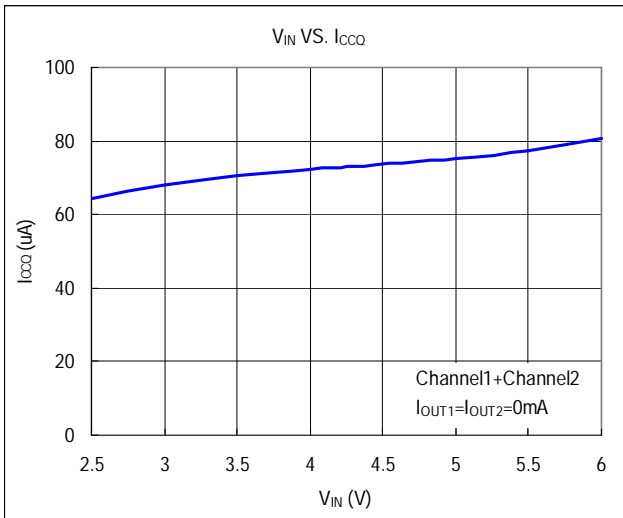



TYPICAL PERFORMANCE CHARACTERISTICS (Continued)

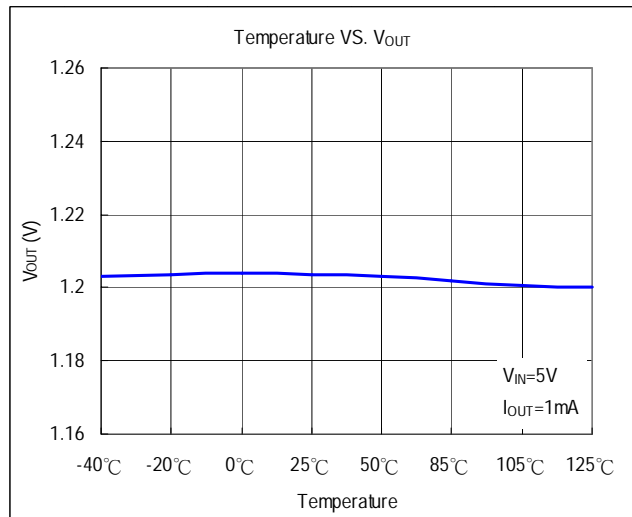
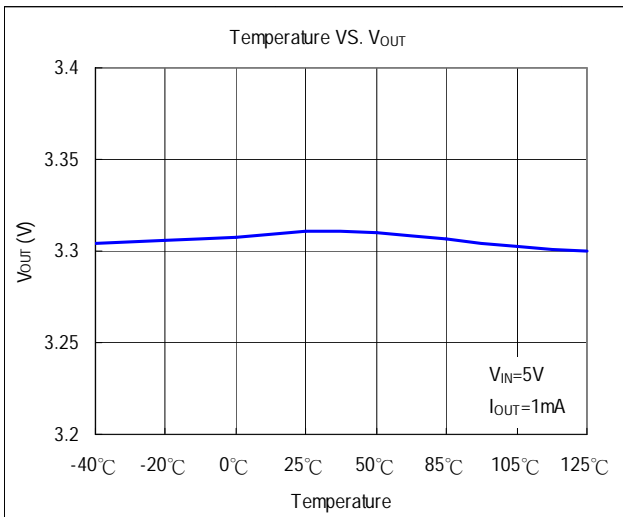
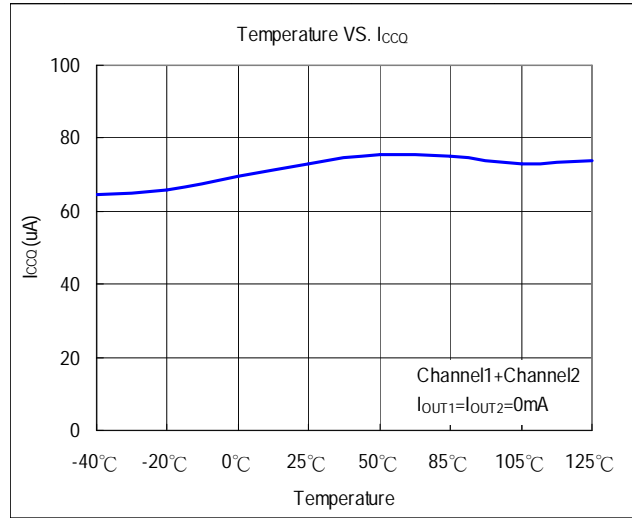
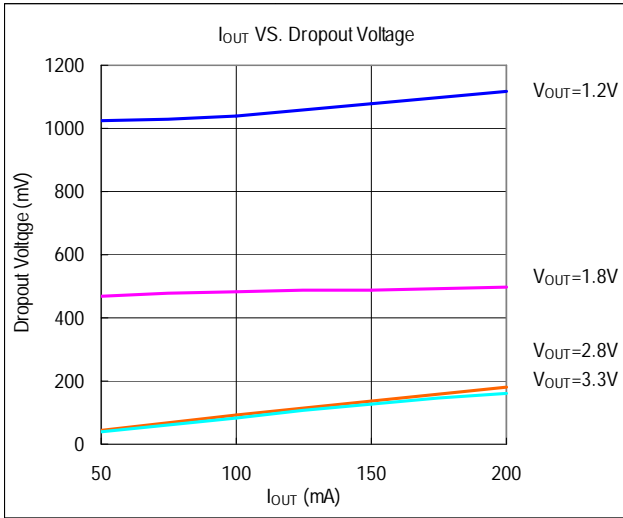



TYPICAL PERFORMANCE CHARACTERISTICS (Continued)

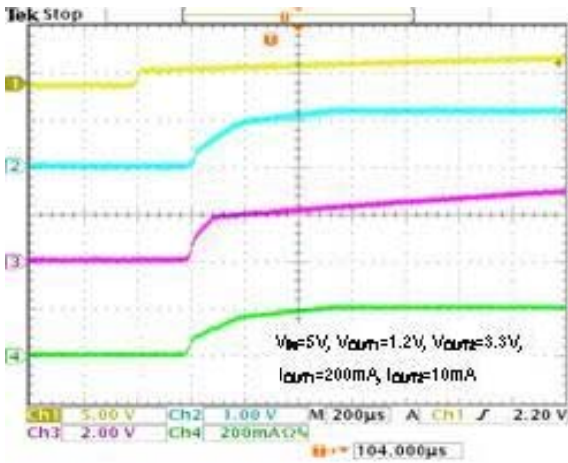

Line Transient

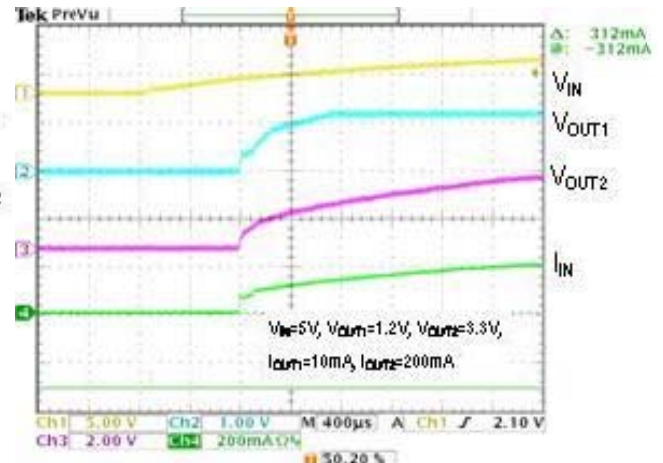

Line Transient

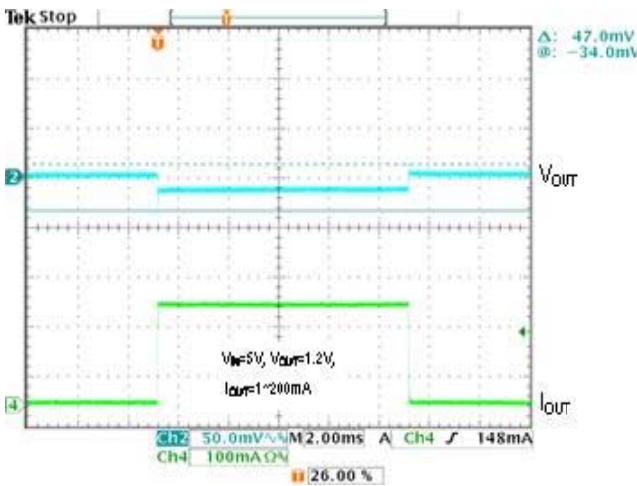

Load Transient

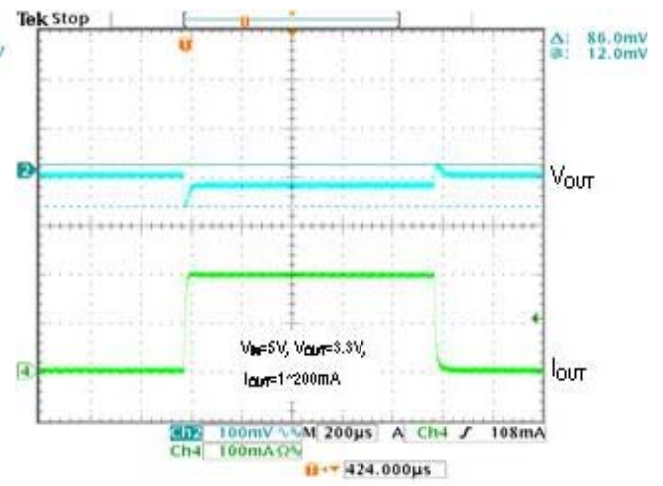

Load Transient

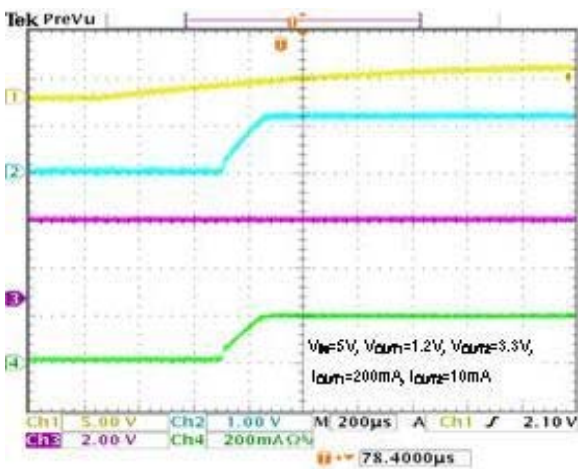

EN ON (EN1)

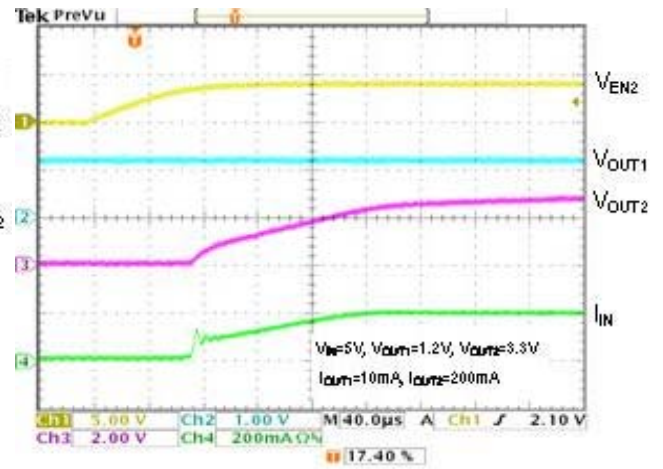

EN ON (EN2)



## **FUNCTION DESCRIPTION**

The APE8837 is a highly accurate, dual, low noise, CMOS LDO voltage regulators with enable function. The output voltage for each regulator is set independently by fuse trimming. As illustrated in function block diagram, it consists of a reference, error amplifier, a P-channel pass transistor, an ON/OFF control logic and an internal feedback voltage divider. The band gap reference is connected to the error amplifier, which compares the reference with the feedback voltage and amplifies the voltage difference. If the feedback voltage is lower than the reference voltage, the pass- transistor gate is pulled lower, which allows more current to pass to the  $V_{OUT}$  pin and increases the output voltage. If the feedback voltage is too high, the pass transistor gate is pulled up to decrease the output voltage. The output voltage is feed back through an internal resistive divider connected to  $V_{OUT}$  pin. Additional blocks include an output current limiter, thermal sensor, and shutdown logic.

### **Enable Function**

EN1 and EN2 pin start and stop the corresponding outputs independently. When the EN pin is switched to the power off level, the operation of all internal circuit stops, the build-in P-channel MOSFET output transistor between pins  $V_{IN}$  and  $V_{OUT}$  is switched off, allowing current consumption to be drastically reduced.

### **Dropout Voltage**

A regulator's minimum input-output voltage differential, or dropout voltage, determines the lowest usable supply voltage. The APE8837 use a P- channel MOSFET pass transistor, its dropout voltage is function of drain-to-source on-resistance  $R_{DS(ON)}$  multiplied by the load current.

$$V_{DROPOUT} = V_{IN} - V_{OUT} = R_{DS(ON)} \times I_{OUT}$$

### **Current Limit**

Each channel of APE8837 includes a fold back current limiter. It monitors and controls the pass transistor's gate voltage, estimates the output current, and limits the output current within 250mA.

### **Thermal Shutdown Protection**

Thermal Shutdown protection limits total power dissipation of APE8837. When the junction temperature exceeds  $T_J = +150^{\circ}\text{C}$ , a thermal sensor turns off the pass transistor, allowing the IC to cool down. The thermal sensor turns the pass transistor on again after the junction temperature cools down by  $40^{\circ}\text{C}$ , resulting in a pulsed output during continuous thermal shutdown conditions.

Thermal shutdown protection is designed to protect the APE8837 in the event of fault conditions. For continuous operation, the absolute maximum operating junction temperature rating of  $T_J = +125^{\circ}\text{C}$  should not be exceeded.





---

## **APPLICATION INFORMATION**

Like any low-dropout regulator, the APE8837 requires input and output decoupling capacitors. The device is specifically designed for portable applications requiring minimum board space and smallest components. These capacitors must be correctly selected for good performance (see Capacitor Characteristics Section). Please note that linear regulators with a low dropout voltage have high internal loop gains which require care in guarding against oscillation caused by insufficient decoupling capacitance.

### **Input Capacitor**

An input capacitance of 2.2uF is required between input pin and ground directly (the amount of the capacitance may be increased without limit). The input capacitor must be located less than 1cm from the device to assure input stability. A lower ESR capacitor allows the use of less capacitance, while higher ESR type (like aluminum electrolytic) requires more capacitance. Capacitor types (aluminum, ceramic and tantalum) can be mixed in parallel, but the total equivalent input capacitance/ ESR must be defined as above to stable operation. There are no requirements for the ESR on the input capacitor, but tolerance and temperature coefficient must be considered when selecting the capacitor to ensure the capacitance will be 1uF over the entire operating temperature range.

### **Output Capacitor**

The APE8837 is designed specifically to work with very small ceramic output capacitors. A ceramic capacitor (temperature characteristics X7R, X5R) in 1uF is suitable for the APE8837 application. The recommended minimum capacitance for the device is 2.2uF, X5R or X7R dielectric ceramic, between  $V_{OUT}$  and GND for stability, but it may be increased without limit. Higher capacitance values help to improve transient. The output capacitor's ESR is critical because it forms a zero to provide phase lead which is required for loop stability.

### **Thermal Considerations**

The APE8837 series can deliver a current of up to 200mA/channel over the full operating junction temperature range. However, the maximum output current must be debated at higher ambient temperature to ensure the junction temperature does not exceed 125°C. With all possible conditions, the junction temperature must be within the range specified under operating conditions. Power dissipation can be calculated based on the output current and the voltage drop across regulator.

$$P_D = (V_{IN} - V_{OUT}) I_{OUT} + V_{IN} \times I_{GND}$$

The final operating junction temperature for any set of conditions can be estimated by the following thermal equation:

$$P_{D(MAX)} = (T_{J(MAX)} - T_A) / R_{thJA}$$

Where  $T_{J(MAX)}$  is the maximum junction temperature of the die (125°C) and  $T_A$  is the maximum ambient temperature. The thermal resistance from junction to ambient ( $R_{\theta JA}$ ) of SOT-26 package at recommended minimum footprint is 250°C/W.



**MARKING INFORMATION**

**SOT-26 / TSOT-26**

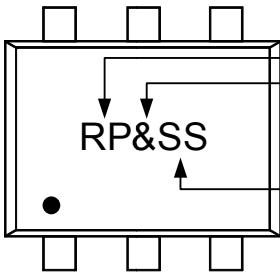

Part Number : RP  
 Output Voltage: see Identification Code

Date Code  
 SS:2004, 2008, 2012...  
 SS:2003, 2007, 2011...  
 SS:2002, 2006, 2010...  
 SS:2001, 2005, 2009...

**DFN 2x2-6L**

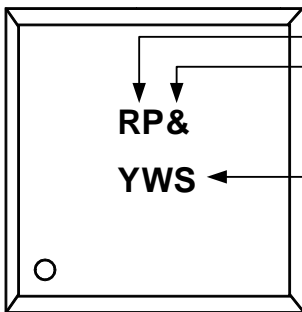

Part Number: RP  
 Output Voltage: see Identification Code

Date Code (YWS)  
 Y : Year  
 W : Week  
 S : Sequence

Identification Code	V <sub>OUT1</sub> +V <sub>OUT2</sub>	Identification Code	V <sub>OUT1</sub> +V <sub>OUT2</sub>	Identification Code	V <sub>OUT1</sub> +V <sub>OUT2</sub>
A	1.5V+2.8V	J	2.8V+3.3V	S	1.2V+1.8V
B	1.8V+2.8V	K	3.0V+3.0V	T	1.5V+3.3V
C	1.8V+2.6V	L	3.0V+3.3V	U	2.5V+2.5V
D	1.8V+3.3V	M	3.3V+3.3V	V	1.5V+3.0V
E	2.5V+2.8V	N	1.2V+3.3V	W	1.2V+2.8V
F	2.8V+1.2V	P	1.8V+3.0V	X	1.2V+1.2V
G	2.8V+1.8V	Q	1.5V+2.5V	Y	2.8V+1.5V
H	2.8V+3.0V	R	3.3V+1.8V	Z	2.8V+2.8V