

Applications

Power Management in Notebook Computer, Portable Equipment and Battery Powered Systems

Features

- 30V/-4.9A, $R_{DS(on)}=53m\Omega(\text{typ.})@V_{GS}=-10V$
- $R_{DS(on)}=53m\Omega(\text{typ.})@V_{GS}=-4.5V$
- Supper High Density Cell Design
- Reliable and Rugged
- SO-8 Package

Pin Description

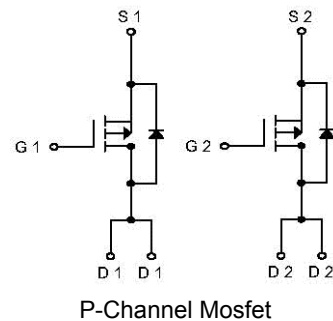
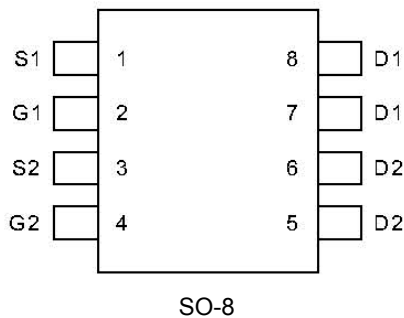

Ordering and Marking Information

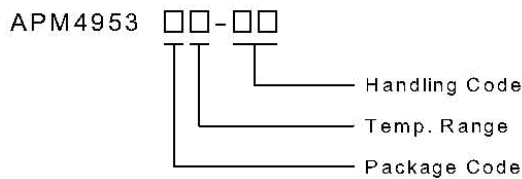

APM4953K: APM4953
XXXXXX

- Package Code
- K: SO-8
- Operation Junction Temp. Range
- C:-55 to 150
- Handling Code
- TU: Tube
- TR: Tape & Reel
- XXXXXX – Date Code

Absolute Maximum Ratings ($T_A=25$ unless otherwise noted)

Symbol	Parameter	Rating	Unit
V_{DSS}	Drain-Source Voltage	-30	V
V_{GSS}	Gate-Source Voltage	± 25	
I_D^*	Storage Temperature Range	-4.9	A
I_{DM}	Thermal Resistance – Junction to Ambient	-30	

* Surface Mounted on FR4 Board, $t \leq 10$ sec.

Absolute Maximum Ratings (Cont.) ($T_A=25$ unless otherwise noted)

Symbol	Parameter	Rating	Unit
P_D	Maximum Power Dissipation	$T_A=25$	2.5
		$T_A=100$	1.0
T_J	Maximum Junction Temperature	150	
T_{STG}	Storage Temperature Range	-55 to 150	
R_{QJA}	Thermal Resistance – Junction to Ambient	50	/W

Electrical Characteristics ($T_A=25$ unless otherwise noted)

Symbol	Parameter	Test Condition	APM4953			Unit
			Min.	Typa.	Max	
Static						
BV_{DSS}	Drain-Source Breakdown Voltage	$V_{GS}=0V, I_{DS}=-250\mu A$	-30			V
I_{DSS}	Zero Gate Voltage Drain Current	$V_{DS}=-24V, V_{GS}=0V$			-1	μA
$V_{GS(th)}$	Gate Threshold Voltage	$V_{GS}=V_{GS}, I_{DS}=-250\mu A$	-1	-1.5	-2	V
I_{GSS}	Gate Leakage Current	$V_{GS}=\pm 25V, V_{DS}=0V$			± 100	nA
$R_{DS(ON)}$	Drain-Source On-state Resistance ^b	$V_{GS}=-10V, I_{DS}=-4.9A$		53	60	m Ω
		$V_{GS}=-4.5V, I_{DS}=-3.6A$		80	95	
V_{SD}	Diode Forward Voltage ^b	$I_{SD}=-1.7A, V_{GS}=0V$		-0.7	-1.3	V
Dynamic^a						
Q_g	Total Gate Charge	$V_{DS}=-15V, V_{GS}=-10V$ $I_D=-4.6A$		22.3	29	nC
Q_{gs}	Gate-Source Charge			4.65		
Q_{gd}	Gate-Drain Charge			2		
$t_{d(on)}$	Turn-on Delay Time	$V_{DD}=-15V, I_D=-2A,$ $V_{GEN}=-10V, R_G=6\Omega$ $R_L=7.5\Omega$		10	18	ns
T_r	Turn-on Rise Time			15	20	
$t_{d(OFF)}$	Turn-off Delay Time			22	38	
T_f	Turn-off Fall Time			15	25	
C_{iss}	Input Capacitance	$V_{GS}=0V$		1260		pF
C_{oss}	Output Capacitance	$V_{DS}=-25V$		340		
C_{rss}	Reverse Transfer Capacitance	Frequency=1.0MHz		220		

Notes

a: Pulse test; pulse width $\leq 300\mu s$, duty cycle $\leq 2\%$

b: Guaranteed by design, not subject to production testing

Typical Characteristics

Output Characteristics

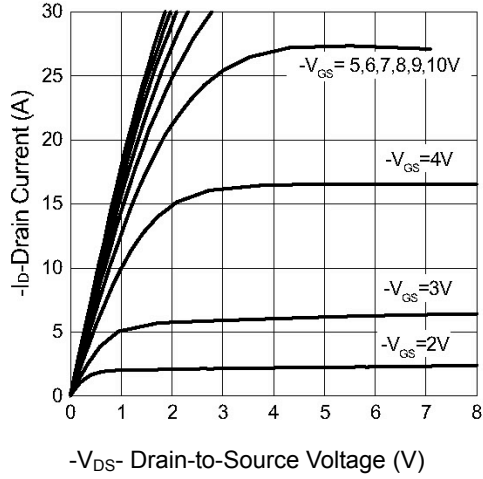

Transfer Characteristics

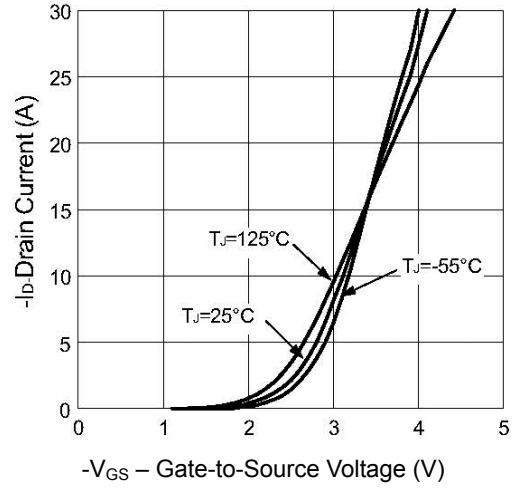

Threshold Voltage vs. Junction Temperature

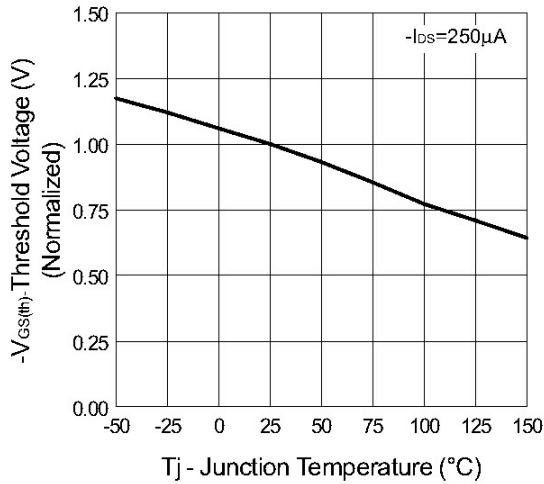

On-Resistance vs. Drain Current

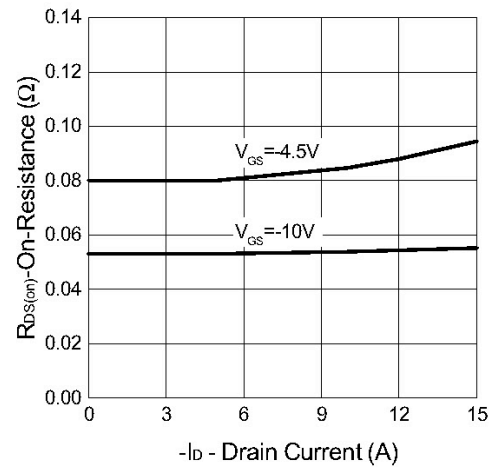

On-Resistance vs. Gate-to-Source Voltage

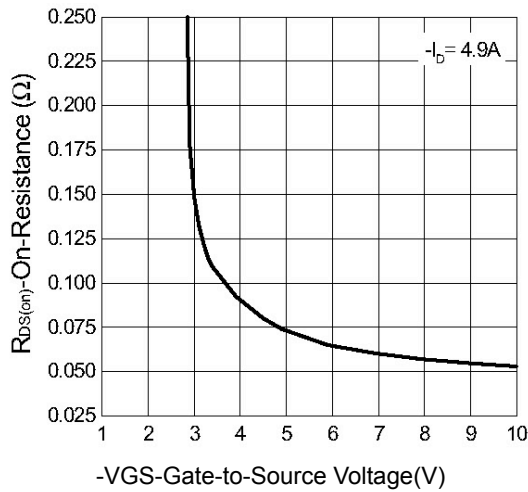

On-Resistance Vs. Junction Temperature

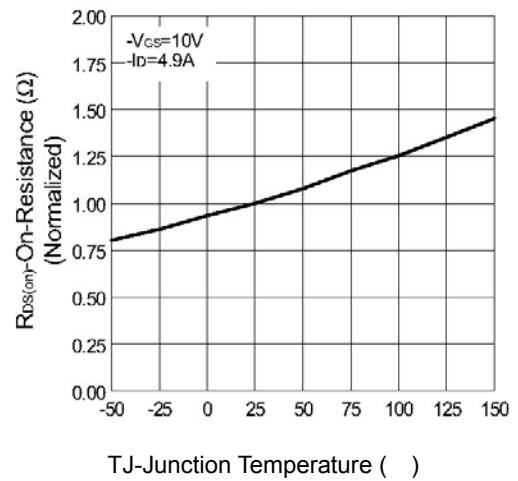

Typical Characteristics (Cont.)

Gate Charge

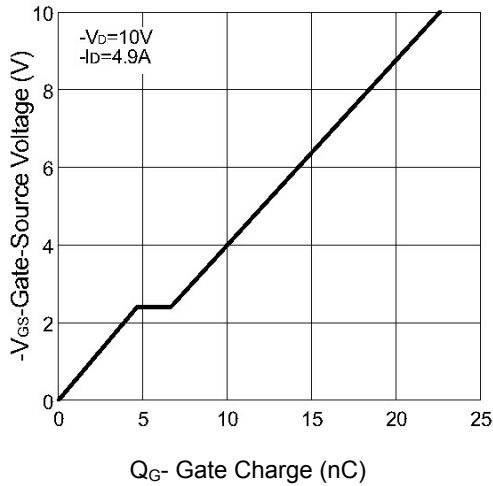

Capacitance

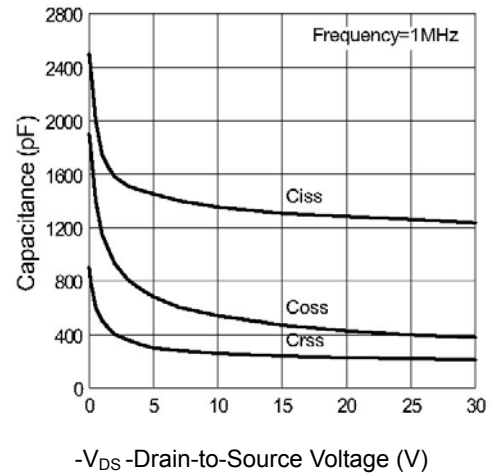

Source-Drain Diode Forward Voltage

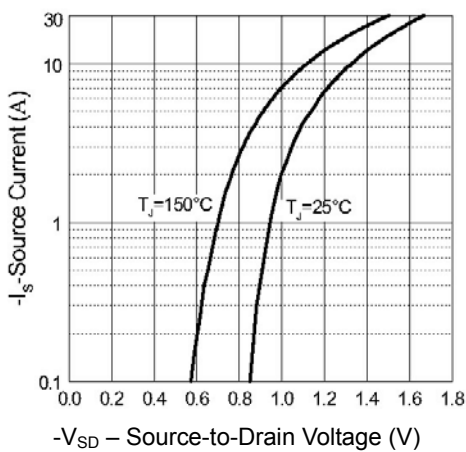

Single Pulse Power

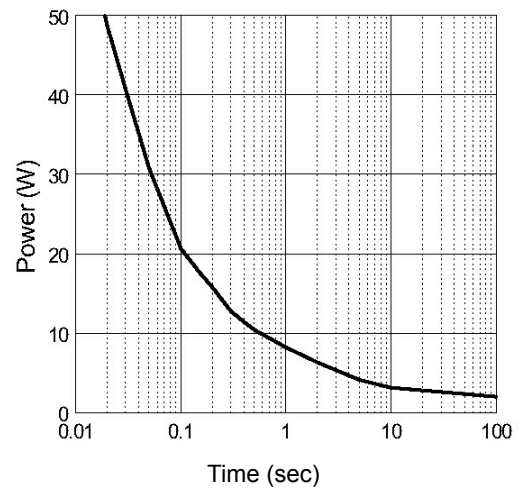

Normalized Thermal Transient Impedance, Junction to Ambient

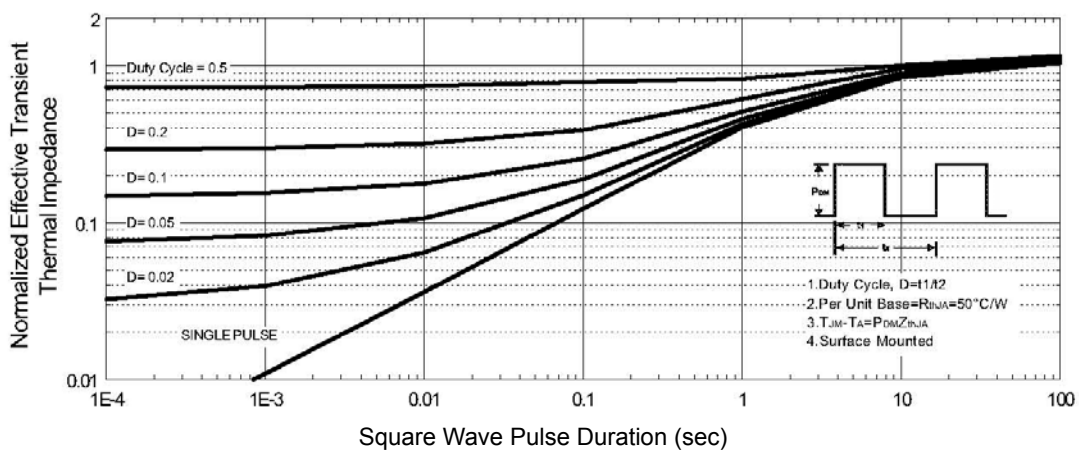

Packaging Information

SOP-8 pin (Reference JEDEC Registration MS-012)

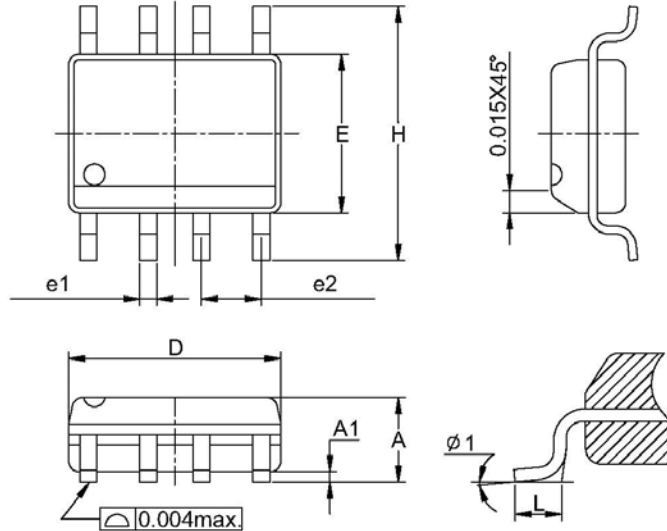

Dim	Millimeters		Inches	
	Min.	Max.	Min.	Max.
A	1.35	1.75	0.053	0.069
A1	0.10	0.25	0.004	0.010
D	4.80	5.00	0.189	0.197
E	3.80	4.00	0.150	0.157
H	5.80	6.20	0.228	0.244
L	0.40	1.27	0.016	0.050
e1	0.33	0.51	0.013	0.020
e2	1.27BSC		0.50BSC	
Ø1	8°		8°	

Physical Specifications

Terminal Material	Solder-Plated Copper (Solder Material: 90/10 or 63/37 SnPb)
Lead Solderability	Meets EIA Specification RS186-91, ANSI/J-STD-002 Category 3.

Reflow Condition (IR/Convection or VPR Reflow)

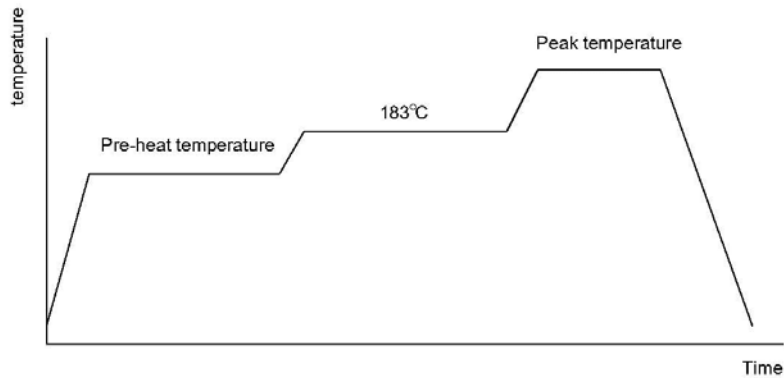

Classification Reflow Profiles

	Convection or IR/Convection	VPR
Average ramp-up rate (183 to Peak)	3 /second max.	10 /second max.
Preheat temperature 125 ±25	120 seconds max	
Temperature maintained above 183	60-150 seconds	
Time within 5 of actual peak temperature	10-20 seconds	60 seconds
Peak temperature range	220 +5/-0 or 235 +5/-0	215-219 or 235 +5/-0
Ramp-down rate	6 /second max.	10 /second max.
Time 25 to peak temperature	6 minutes max.	

Package Reflow Conditions

Pkg. thickness ≥2.5mm And all bgas	Pkg. thickness <2.5mm and pkg. volume ≥350mm ³	Pkg. thickness < 2.5mm and pkg. Volume <350mm ³
Convection 220 +5/-0		Convection 235 +5/-0
VPR 215-219		VPR 235 +5/-0
IR/Convection 220 +5/-0		IR/Convection 235 +5/-0

Reliability test program

Test item	Method	Description
SOLDERABILITY	MIL-STD-883D-2003	245 , 5 SEC
HOLT	MIL-STD 883D-1005.7	1000 Hrs Bias @ 125
PCT	JESD-22-B, A102	168 Hrs, 100% RH,121
TST	MIL-STD 883D-1011.9	-65 ~ 150 , 200 Cycles

Carrier Tape & Reel Dimensions

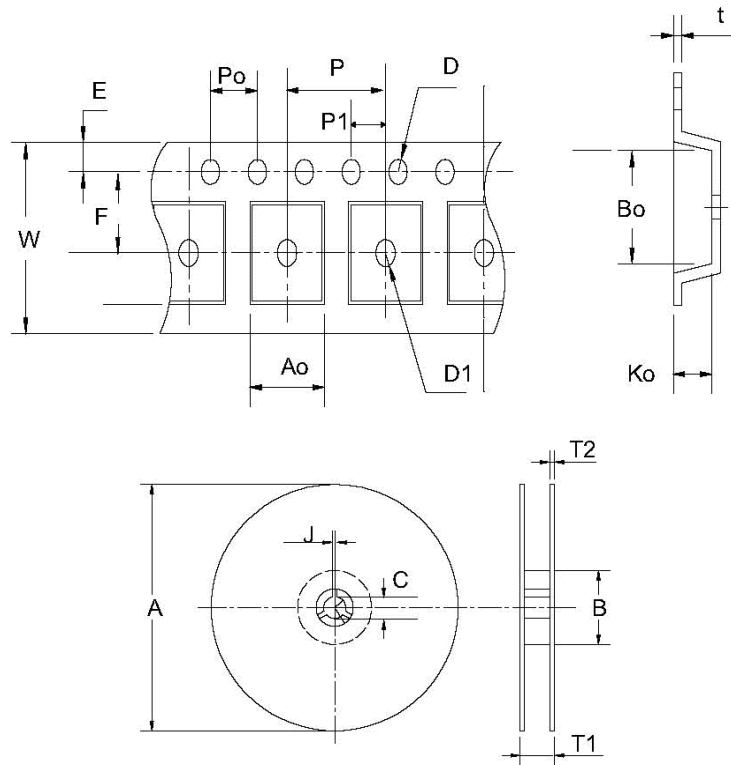



APM4953
Dual P-Channel Enhancement Mode Mosfet

Application	A	B	C	J	T1	T2	W	P	E
SOP-8	330±1	62+1.5	12.75+0.15	2±0.5	12.4±0.2	2±0.2	12±0.3	8±0.1	1.75±0.1
	F	D	D1	Po	P1	Ao	Bo	Ko	t
	5.5±1	1.55+0.1	1.55+0.25	4.0±0.1	2.0±0.1	6.4±0.1	5.2±0.1	2.1±0.1	0.3±0.013

Cover Tape Dimensions

Application	Carrier Width	Cover Tape Width	Devices Per Reel
SOP-8	12	9.3	2500