

**PUMP EXPRESS™ COMPATIBLE AC/DC PSR SWITCHER**

NEW PRODUCT

**Description**

The APS39903 is a high accuracy and low cost switching mode power supply switcher for battery charger/adaptor applications. It consists of a primary side regulation controller and a high voltage transistor. The controller regulates the output voltage and current in the primary side by piece-wise Pulse Frequency Modulation (p-PFM) in discontinuous conduction mode (DCM). The switcher uses adaptive source current to optimize driving current to reduce driving loss. The system operating frequency reduces linearly from heavy load to light load in each interval of the p-PFM, and enters constant current mode when the load current is equal to the maximum system output current. The output voltage and output current limit of APS39903 can be adjusted based on the patterns of load current aligned to MTK Pump Express protocol.

The APS39903 provides operating frequency Jitter function from light to full load range to improve the power supply EMI performance. The APS39903 also has built-in fixed cable voltage drop compensation (6% of nominal system output voltage) and adjustable line voltage compensation.

The APS39903 can work individually to achieve Ultra-Low standby power under 5V output.

The APS39903 is packaged in SO-7.

**Applications**

- Adapters/Chargers

Notes:

1. No purposely added lead. Fully EU Directive 2002/95/EC (RoHS) & 2011/65/EU (RoHS 2) compliant.
2. See [http://www.diodes.com/quality/lead\\_free.html](http://www.diodes.com/quality/lead_free.html) for more information about Diodes Incorporated's definitions of Halogen- and Antimony-free, "Green" and Lead-free.
3. Halogen- and Antimony-free "Green" products are defined as those which contain <900ppm bromine, <900ppm chlorine (<1500ppm total Br + Cl) and <1000ppm antimony compounds.

**Pin Assignments**

(Top View)

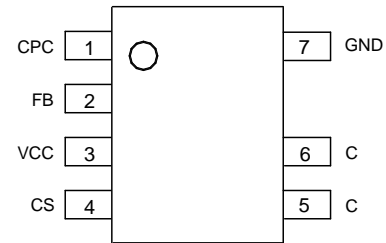

SO-7

**Features**

- Compatible to MediaTek Pump Express™ Protocol
- Ultra-Low Standby Power Consumption
- Built-in NPN Transistor with 700V<sub>CBO</sub>
- Valley-turn On to Reduce Switching Loss and Benefit for EMI
- Piece-wise Frequency Reduction to Enhance Conversion Efficiency and Suppress Audio Noise
- ±5% Constant Voltage Accuracy for 5V Output
- Audio Noise Suppression
- Open Circuit Protection (OCP)
- Current Sense Resistor Short Protection
- Over Voltage Protection (OVP)
- Over Temperature Protection (OTP)
- Short Circuit Protection (SCP) with Hiccup
- **Totally Lead-Free & Fully RoHS Compliant (Notes 1 & 2)**
- **Halogen and Antimony Free. "Green" Device (Note 3)**

**Typical Applications Circuit**

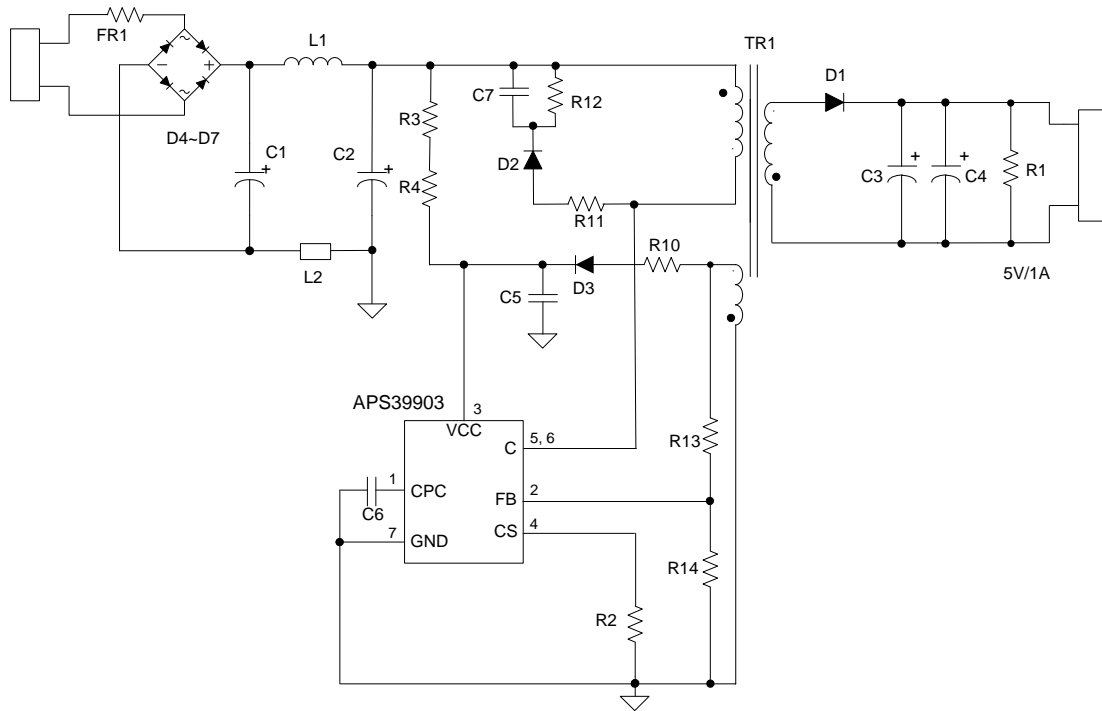

NEW PRODUCT

**Pin Descriptions**

Pin Number	Pin Name	Function
1	CPC	A capacitor is connected to this pin to form a low pass filter for cable voltage drop compensation, audio noise suppression and detecting the patterns of load current to change the output voltage and current
2	FB	The CV and CC regulation are realized base on the voltage sampling of this pin
3	VCC	VCC supply pin for the switcher. A capacitor with low ESR should be placed as close as possible to this pin
4	CS	Current senses pin of IC. The CS pin will turn off the power transistor when the CS pin voltage reaches turn off threshold.
5, 6	C	This pin is connected with an internal power BJT's collector
7	GND	The ground of the switcher

**Functional Block Diagram**

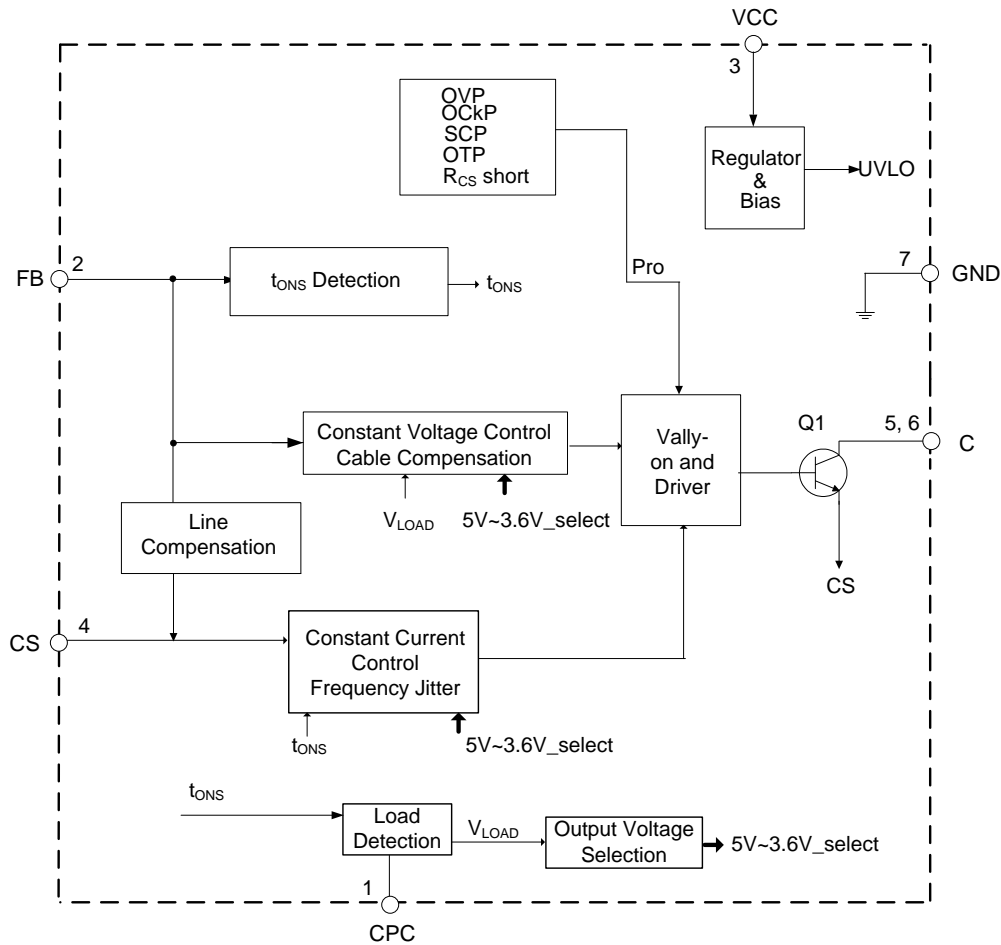

**Absolute Maximum Ratings** (Note 4)

Symbol	Parameter	Rating	Unit
V <sub>CC</sub>	Supply Voltage	-0.3 to 35	V
V <sub>CS</sub> , V <sub>CPC</sub>	Voltage on CS, CPC Pin	-0.3 to 7	V
V <sub>FB</sub>	FB Input Voltage	-0.3 to 8	V
V <sub>CBO</sub>	Collector-emitter Voltage	700	V
–	Collector DC Current	1.5	A
P <sub>D</sub>	Total Power Dissipation	0.7	W
T <sub>J</sub>	Operating Junction Temperature	-40 to +150	°C
T <sub>STG</sub>	Storage Temperature	-65 to +150	°C
T <sub>LEAD</sub>	Lead Temperature (Soldering, 10 sec)	+300	°C
θ <sub>JA</sub>	Thermal Resistance (Junction to Ambient)	100	°C/W
ESD	ESD (Human Body Model)	4000	V
	ESD (Machine Model)	300	V

Note 4: Stresses greater than those listed under “Absolute Maximum Ratings” may cause permanent damage to the device. These are stress ratings only, and functional operation of the device at these or any other conditions beyond those indicated under “Recommended Operating Conditions” is not implied. Exposure to “Absolute Maximum Ratings” for extended periods may affect device reliability.

**Electrical Characteristics** (@V<sub>CC</sub> = 12V, T<sub>A</sub> = +25°C, unless otherwise specified.)

Symbol	Parameters	Conditions	Min	Typ	Max	Unit
<b>STARTUP AND UVLO SECTION</b>						
V <sub>TH_ST</sub>	Startup Threshold	–	13	15.5	18	V
V <sub>OPR(MIN)</sub>	Minimal Operating Voltage	–	5.2	5.8	6.4	V
<b>STANDBY CURRENT SECTION</b>						
I <sub>ST</sub>	Startup Current	V <sub>CC</sub> = V <sub>TH_ST</sub> -1V before startup	0	0.2	0.6	μA
I <sub>CC_QST</sub>	Quiescent Current	Static current	435	500	565	
<b>DRIVING OUTPUT SECTION</b>						
I <sub>OUT(MAX)</sub>	The Maximum Source Current	–	25	32	39	mA
<b>POWER TRANSISTOR SECTION</b>						
V <sub>CE(SAT)</sub>	Collector-emitter Saturation Voltage	I <sub>C</sub> =0.5A	–	–	0.3	V
h <sub>FE</sub>	DC Current Gain	–	14	17	–	–
I <sub>CEO</sub>	Leakage Current	–	–	–	60	nA
<b>OPERATING FREQUENCY SECTION (5% Load to Full Load)</b>						
t <sub>OFF(MAX)</sub>	Maximum Off Time	–	691	768	845	μs
t <sub>SAMPLE</sub>	Sampling Time	37% to 100% full load	5.4	6	6.6	μs
		4% to 37% full load	3.2	3.6	4.0	μs
		0% to 4% full load (Note 5)	2.25	2.5	2.75	μs
<b>FREQUENCY JITTER</b>						
ΔV <sub>CS</sub> /V <sub>CS</sub>	V <sub>CS</sub> Modulation	7% to 100% full load	2	3	4	%
t <sub>MOD</sub>	V <sub>CS</sub> Modulation Period	–	230	256	282	μs
<b>CURRENT SENSE SECTION</b>						
V <sub>CS_H</sub> (V <sub>O</sub> ≥4.4V)	Current Sense Threshold	37% to 100% full load	830	900	970	mV
V <sub>CS_H</sub> (V <sub>O</sub> <4.4V)			940	1020	1100	
V <sub>CS_M</sub>			550	600	650	
V <sub>CS_L</sub>			320	350	380	
R <sub>LINE</sub>	Built-in Line Compensation Resistor	–	260	330	400	Ω
t <sub>LEB</sub>	Leading Edge Blanking	V <sub>CS_H</sub> and V <sub>CS_M</sub>	425	500	575	ns
		V <sub>CS_L</sub> (Note 5)	170	200	230	
<b>CONSTANT VOLTAGE SECTION</b>						
V <sub>FB@5V</sub>	Feedback Threshold Voltage	–	3.94	4.0	4.06	V

**Electrical Characteristics** (@V<sub>CC</sub> = 12V, T<sub>A</sub> = +25°C, unless otherwise specified.) (Cont.)

Symbol	Parameters	Conditions	Min	Typ	Max	Unit
V <sub>FB@4.8V</sub>	Feedback Threshold Voltage	-	3.75	3.85	3.95	V
V <sub>FB@4.6V</sub>			3.61	3.7	3.79	
V <sub>FB@4.4V</sub>			3.47	3.56	3.65	
V <sub>FB@4.2V</sub>			3.32	3.41	3.5	
V <sub>FB@4V</sub>			3.18	3.26	3.34	
V <sub>FB@3.8V</sub>			3.03	3.11	3.19	
V <sub>FB@3.6V</sub>			2.89	2.96	3.03	
R <sub>FB</sub>	FB Pin Input Resistance	V <sub>FB</sub> =4V	560	700	840	kΩ
V <sub>CABLE</sub> /V <sub>OUT</sub> %	Cable Compensation Ratio@5V	-	5	6	7	%
<b>CONSTANT CURRENT SECTION</b>						
t <sub>ONS</sub> /t <sub>SW</sub> @5V & 4.2V	Maximum Secondary Duty Cycle	V <sub>FB</sub> =2V (Note 5)	0.47	0.5	0.53	-
t <sub>ONS</sub> /t <sub>SW</sub> @4.8V & 4V			0.49	0.52	0.55	
t <sub>ONS</sub> /t <sub>SW</sub> @4.6V & 3.8V			0.51	0.54	0.57	
t <sub>ONS</sub> /t <sub>SW</sub> @4.4V & 3.6V			0.53	0.56	0.59	
<b>DYNAMIC SECTION</b>						
V <sub>UV_H</sub>	Under Voltage of Feedback Pin for V <sub>CS_H</sub>	(Note 5)	3.61	3.68	3.75	V
<b>OUTPUT VOLTAGE SELECTION SECTION</b>						
V <sub>CPC_L</sub>	Current Control Threshold	V <sub>CPC</sub> control_L	-	88	-	mV
V <sub>CPC_H</sub>		V <sub>CPC</sub> control_H	-	150	-	
t <sub>ON_A</sub>	Current Control Pattern Time	(Note 5)	400	500	600	ms
t <sub>ON_B</sub>			220	300	380	
t <sub>ON_C</sub>			50	100	150	
t <sub>OFF_D</sub>			50	100	150	
t <sub>WDT</sub>	Watch Dog Time	-	180	210	240	ms
<b>PROTECTION FUNCTION SECTION</b>						
V <sub>FB(OVP)</sub>	Over Voltage Protection	-	7.1	7.5	7.9	V
V <sub>CC(OVP)</sub>	Over Voltage Protection at VCC Pin	-	27	30	33	V
V <sub>FB(SCP)</sub>	Short Circuit Protection	V <sub>FB</sub> @ Hiccup	1.61	1.7	1.79	V
t <sub>SCP</sub>	Maximum Time under V <sub>FB(SCP)</sub>	-	116	128	140	ms
T <sub>OTP</sub>	Shutdown Temperature	-	+128	+140	+152	°C
T <sub>HYS</sub>	Temperature Hysteresis	-	+36	+40	+44	°C

Note 5: Guaranteed by design.

## Operation Principle Description

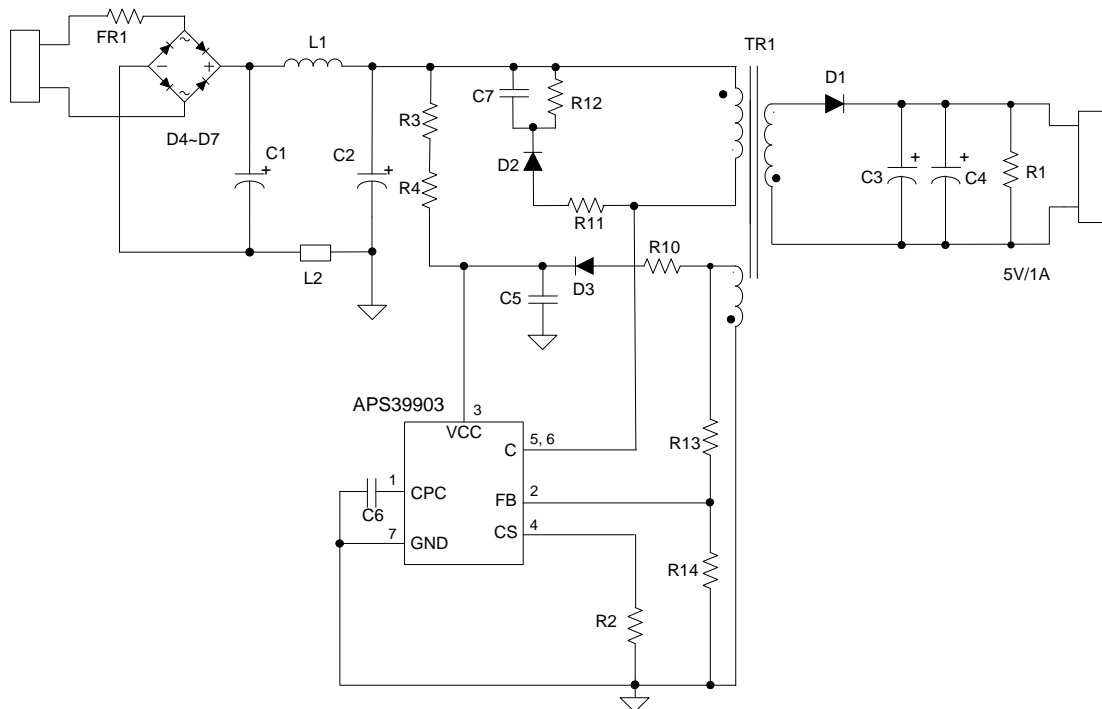

Figure 1. 5W Battery Charger

Figure 1 is the typical application circuit of APS39903, which is a conventional Flyback converter with a 3-winding transformer---primary winding ( $N_p$ ), secondary winding ( $N_s$ ) and auxiliary winding ( $N_{aux}$ ). The auxiliary winding is used for providing VCC supply voltage for IC and sensing the output voltage feedback signal to FB pin.

Figure 2 shows the typical waveforms which demonstrate the basic operating principle of APS39903 application. And the parameters are defined as following.

$I_p$ ---The primary side current

$I_s$  ---The secondary side current

$I_{PK}$ ---Peak value of primary side current

$I_{PKS}$ ---Peak value of secondary side current

$V_{SEC}$ ---The transient voltage at secondary winding

$V_S$ ---The stable voltage at secondary winding when rectification diode is in conducting status, which equals the sum of output voltage  $V_{OUT}$  and the forward voltage drop of diode

$V_{AUX}$ ---The transient voltage at auxiliary winding

$V_A$ --- The stable voltage at auxiliary winding when rectification diode is in conducting status, which equals the sum of voltage VCC and the forward voltage drop of auxiliary diode

$t_{sw}$  ---The period of switching frequency

$t_{ONP}$  ---The conduction time when primary side switch is "ON"

$t_{ONS}$  ---The conduction time when secondary side diode is "ON"

$t_{OFF}$  ---The dead time when neither primary side switch nor secondary side diode is "ON"

$t_{OFFS}$  --- The time when secondary side diode is "OFF"

**Operation Principle Description (Cont.)**

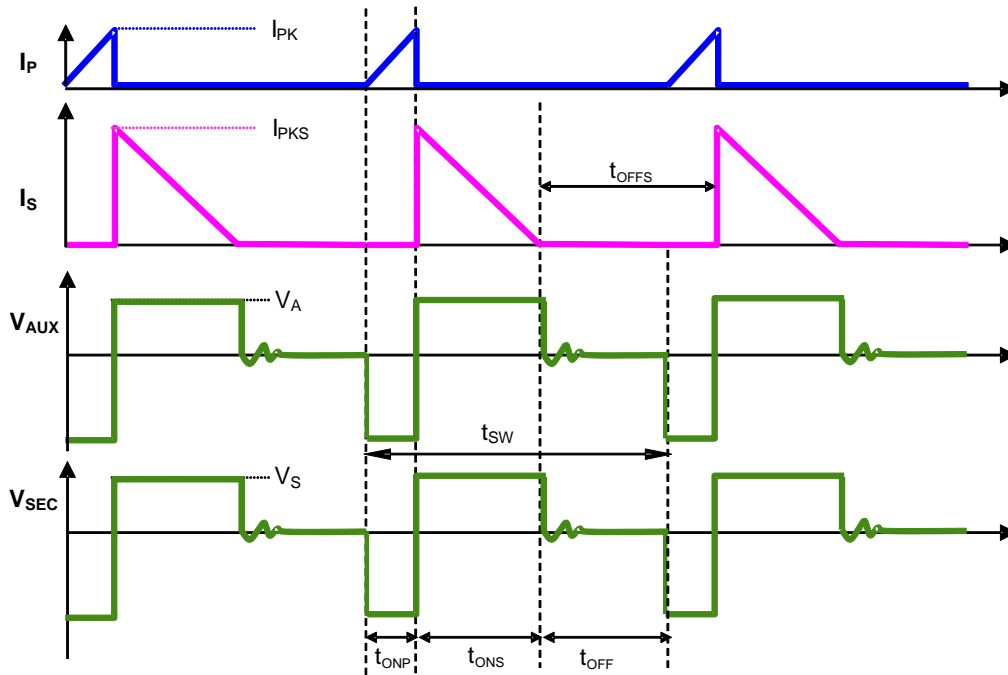

Figure 2. The Operation Waveform of Flyback PSR System

For primary-side regulation, the primary current  $i_p(t)$  is sensed by a current sense resistor  $R_{CS}$  ( $R_2$  as shown in Figure 1). The current rises up linearly at a rate of:

$$\frac{di_p(t)}{dt} = \frac{V_{IN}(t)}{L_M} \quad (1)$$

As illustrated in Figure 2, when the current  $i_p(t)$  rises up to  $I_{PK}$ , the switch Q1 turns off. The constant peak current is given by:

$$I_{PK} = \frac{V_{CS}}{R_{CS}} \quad (2)$$

The energy stored in the magnetizing inductance  $L_M$  each cycle is therefore:

$$E_g = \frac{1}{2} \times L_M \cdot I_{PK}^2 \quad (3)$$

So the power transferring from the input to the output is given by:

$$P = \frac{1}{2} \times L_M \times I_{PK}^2 \times f_{SW} \quad (4)$$

Where, the  $f_{SW}$  is the switching frequency. When the peak current  $I_{PK}$  is constant, the output power depends on the switching frequency  $f_{SW}$ .

**Constant Voltage Operation**

As to constant-voltage (CV) operation mode, the APS39903 detects the auxiliary winding voltage at FB pin to regulate the output voltage. The auxiliary winding voltage is coupled with secondary side winding voltage, so the auxiliary winding voltage at D1 conduction time is:

$$V_{AUX} = \frac{N_{AUX}}{N_S} \times (V_o + V_d) \quad (5)$$

Where the  $V_d$  is the diode forward voltage drop.

**Operation Principle Description (Cont.)**

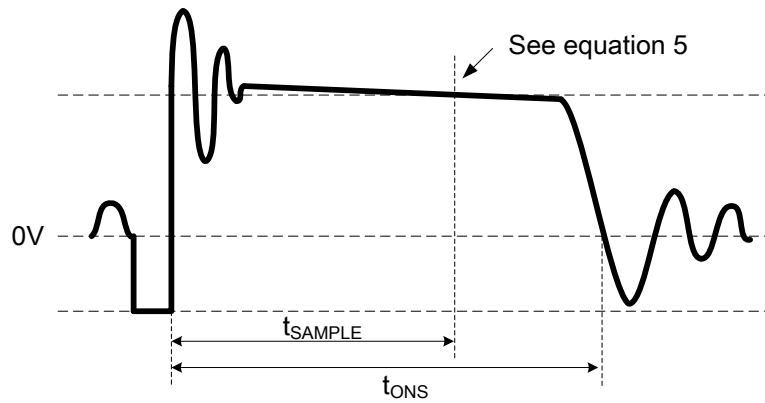

Figure 3. Auxiliary Voltage Waveform

The voltage detection point is at a constant delay time of the D1 on-time. The constant delay time is changed with the different primary peak current. The CV loop control function of APS39903 then generates a D1 off-time to regulate the output voltage.

**Constant Current Operation**

The APS39903 can work in constant-current (CC) mode. Figure 2 shows the secondary current waveforms.

In CC operation mode, the CC control loop of APS39903 will keep a fixed proportion between D1 on-time  $t_{ONS}$  and D1 off-time  $t_{OFFS}$ . The fixed proportion is

$$\frac{t_{ONS}}{t_{OFFS}} = \frac{4}{4} \quad (6)$$

The relationship between the output current and secondary peak current  $I_{PKS}$  is given by:

$$I_{OUT} = \frac{1}{2} \times I_{PKS} \times \frac{t_{ONS}}{t_{ONS} + t_{OFFS}} \quad (7)$$

As to tight coupled primary and secondary winding, the secondary peak current is

$$I_{PKS} = \frac{N_P}{N_S} \times I_{PK} \quad (8)$$

Thus the output constant-current is given by:

$$I_{OUT} = \frac{1}{2} \times \frac{N_P}{N_S} \times I_{PK} \times \frac{t_{ONS}}{t_{ONS} + t_{OFFS}} = \frac{2}{8} \times \frac{N_P}{N_S} \times I_{PK} \quad (9)$$

Therefore, APS39903 can realize CC mode operation by constant primary peak current and fixed diode conduction duty cycle.

**Multiple Segment Constant Peak Current**

As to the original PFM PSR system, the switching frequency decreases with output current decreasing, which will encounter audible noise issue since switching frequency decreases to audio frequency range, about less than 20kHz.

In order to avoid audible noise issue, APS39903 uses 3-segment constant primary peak current control method. At constant voltage mode, the current sense threshold voltage is multiple segment with different loading, as shown in Figure 4, which are  $V_{CS\_H}$  for high load,  $V_{CS\_M}$  for medium load and  $V_{CS\_L}$  for light load. At constant current mode, the peak current is still  $V_{CS\_H}$ .



**Operation Principle Description (Cont.)**

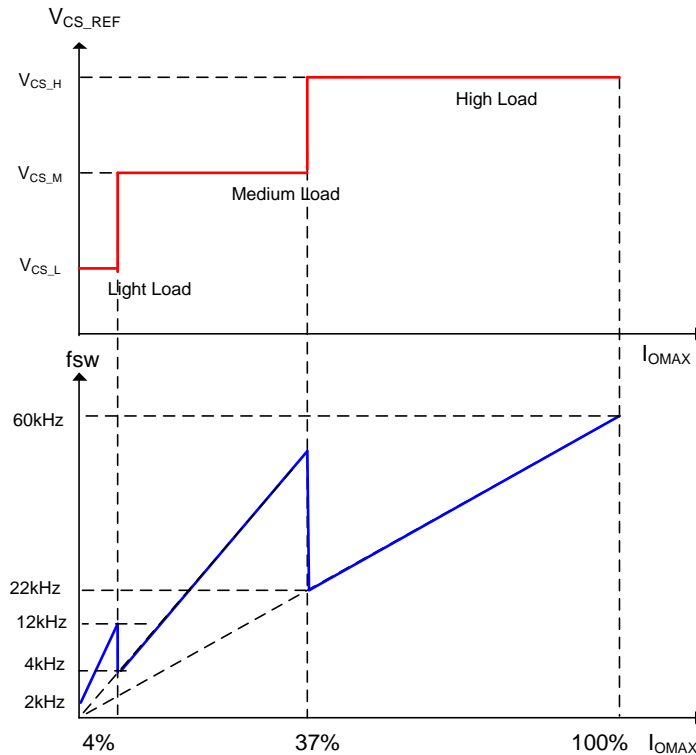

Figure 4. Multiple Segment Peak Current at CV Mode

It can be seen from Figure 4, with multiple segment peak current control, APS39903 power system can get the good audible noise performance.

**Leading Edge Blanking (LEB) Time**

When the power switch is turned on, a turn-on spike will occur on the sense-resistor. To avoid false turn off switch, a 500ns leading-edge blanking is built in. During this blanking time, the current sense comparator is disabled and the external power switch cannot be turned off. Furthermore, because of multiple segment peak current design, the required maximum on time  $t_{ONP}$  changes with different load condition. Therefore the LEB time parameter also changes with different load condition.

**Adjustable Line Compensation and Fixed Cable Compensation**

The APS39903 power system can adjust line compensation by changing the upper resistor at FB pin. The line compensation capability is increased by decreasing the resistance of the upper FB resistor.

Cable compensation is fixed in APS39903.

**Valley Turn-on**

When the off time ( $t_{OFF}$ ) is lower than 32 $\mu$ s, APS39903 power system can work with valley turn on. It can reduce BJT switching on power losses which is result from the equivalent output capacitance. At the same time, because of valley turn on the switching frequency has the random jitter feature, which will be benefit for conductive EMI performance. And valley turn on can also reduce the power switch turn on spike current and then result in the better radiative EMI performance.

**Frequency Jitter**

Even though the valley turn on function can lead the random frequency jitter feature, an active frequency jitter function is added to APS39903 to ensure the frequency jitter performance in the whole loading condition. By adjusting the  $V_{CS\_REF}$  with deviation of 3.0% in a random pulse sequence, the active frequency jitter can be realized with 256 $\mu$ s repetitive cycles.

**Operation Principle Description (Cont.)**

**Output Voltage Selection Section**

The output voltage and output current of APS39903 can be adjusted based on the patterns of load current aligned to MTK Pump Express protocol.

The Voltage of CPC pin of APS39903 is changed with the load current. APS39903 can detect the load current patterns through CPC pin. The pattern of decrease output voltage is shown in Figure 5 and the pattern of increase output voltage is shown in Figure 6.

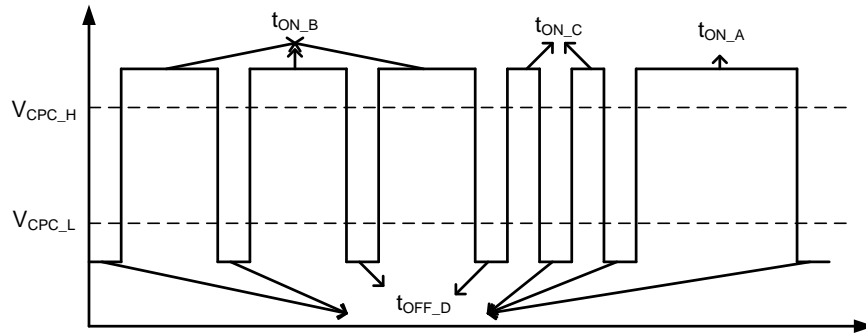

Figure 5. The Pattern of Decrease Output Voltage

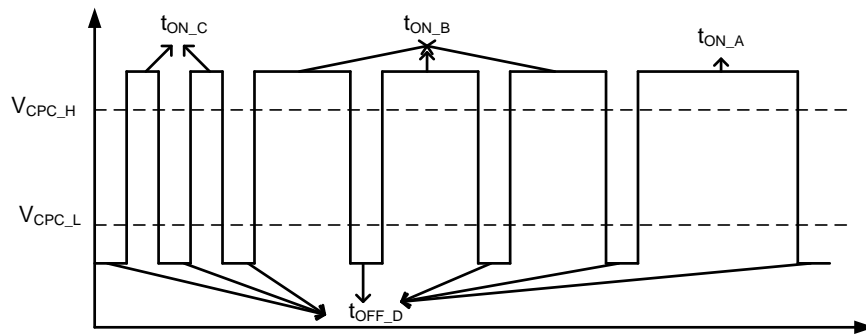

Figure 6. The Pattern of Increase Output Voltage

Just shown as Figure 7, the voltage is changed step by step among 4.8V and 3.6V. When the APS39903 detects one full pattern of decrease output voltage, the output voltage will decrease 0.2V from the current voltage level. When the output voltage is 3.6V, the pattern of decrease output voltage is invalid. When the APS39903 detects one full pattern of increase output voltage, the output voltage will increase 0.2V from the current voltage level. At any voltage level among 4.8V to 3.6V, once the WDT function ( $V_{CPC} < V_{CPC\_L}$  and the time of duration is more than  $t_{WDT}$ .) is triggered, the output voltage will return to 5V directly. And At any voltage level among 4.8V to 3.6V, once any protect function is triggered, the output voltage will return to 5V directly.

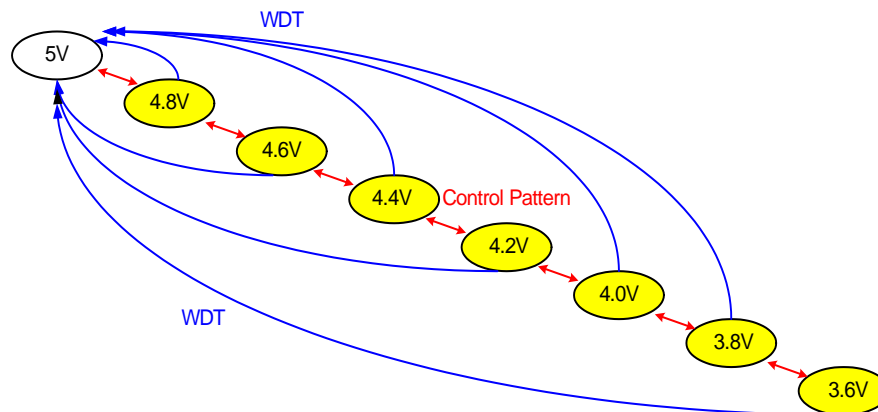

Figure 7. Voltage State Flow

## Operation Principle Description (Cont.)

### CCM Protection

The APS39903 is designed to operate in discontinuous conduction mode (DCM) in both CV and CC modes. To avoid operating in continuous conduction mode (CCM), the APS39903 detects the falling edge of the FB input voltage on each cycle. If a 0V falling edge of FB is not detected, the APS39903 stops working.

### OVP & OckP

The APS39903 includes output over-voltage protection (OVP) and open circuit protection (OckP) circuitry. If the voltage at FB pin exceeds 7.5V, 90% above the normal detection voltage, or the 0V falling edge of the FB input can't be monitored, the APS39903 immediately shuts down and keeps the internal circuitry enabled to discharge the VCC capacitor to the UVLO turn-off threshold. After that, the device returns to the start state and a start-up sequence ensues.

### Short Circuit Protection (SCP)

Short Circuit Protection (SCP) detection principle is similar to the normal output voltage feedback detection by sensing FB pin voltage. When the detected FB pin voltage is below  $V_{FB(SCP)}$  for a duration of about  $t_{SCP}$ , the SCP is triggered. Then the APS39903 enters hiccup mode that the IC immediately shuts down and then restarts, so that the VCC voltage changes between  $V_{TH\_ST}$  and UVLO threshold until  $V_{FB(SCP)}$  condition is removed.

As to the normal system startup, the time duration of FB pin voltage below  $V_{FB(SCP)}$  should be less than  $t_{SCP}$  to avoid entering SCP mode. But for the output short condition or the output voltage below a certain level, the SCP mode should happen.

Figure 8 is the APS39903 normal start-up waveform that the voltage of FB pin is above  $V_{FB(SCP)}$  during  $t_{SCP}$  after  $V_{CC}$  gets to the  $V_{TH\_ST}$ , which doesn't enter the SCP mode. As shown in Figure 9,  $V_{OUT}$  is short and the voltage of FB pin is lower than  $V_{FB(SCP)}$  over than  $t_{SCP}$ , the APS39903 triggers the SCP and enters the hiccup mode.

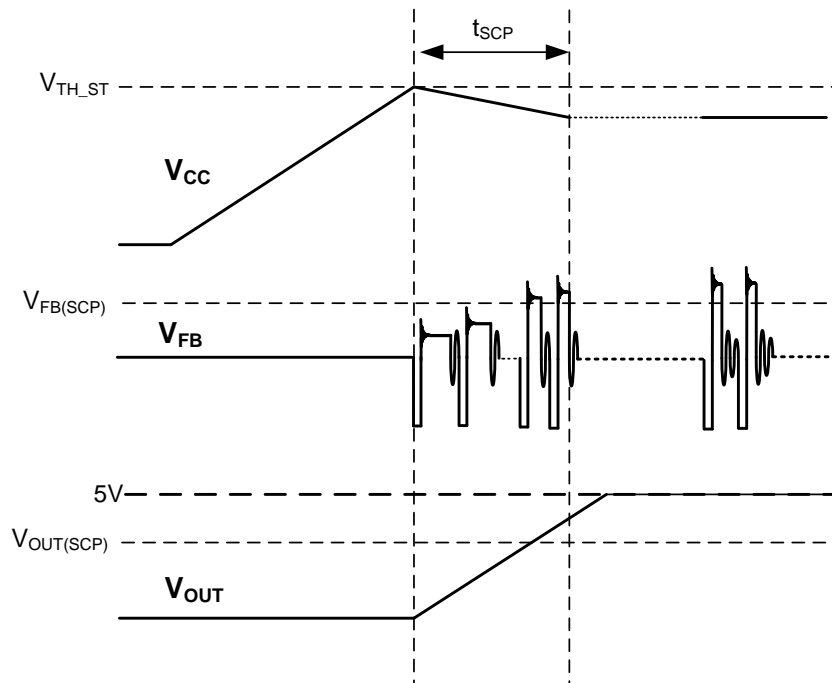

Figure 8. Normal Start-up

**Operation Principle Description (Cont.)**

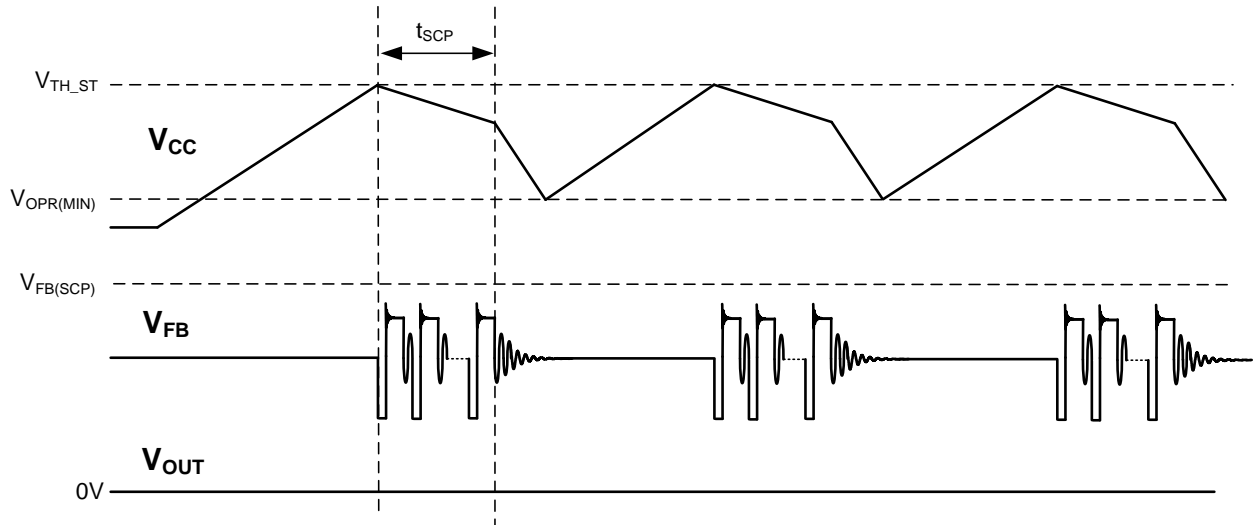

Figure 9. Short Circuit Protection (SCP) and Hiccup Mode

**OTP**

If the junction temperature reaches the threshold of +140°C, APS39903 shuts down immediately. Before V<sub>CC</sub> voltage decreases to UVLO, if the junction temperature decreases to +100°C, APS39903 can recover to normal operation. If not, the power system enters restart Hiccup mode until the junction temperature decreases below +100°C.

**Performance Characteristics**

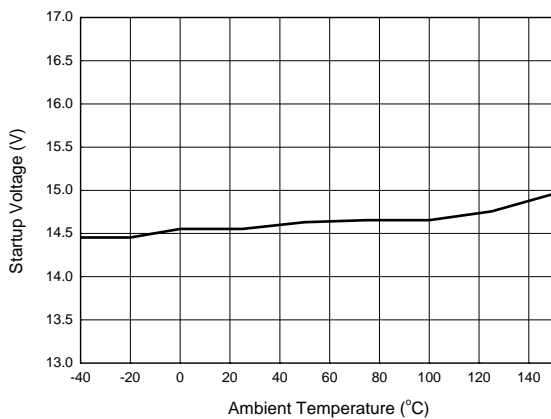

Figure 10. Startup Voltage vs. Ambient Temperature

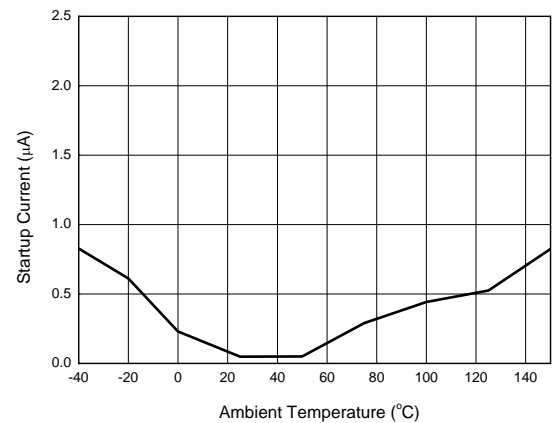

Figure 11. Startup Current vs. Ambient Temperature

**Performance Characteristics (Cont.)**

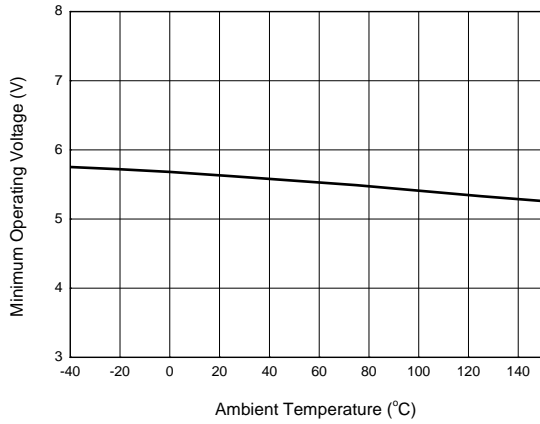

Figure 12. Minimum Operating Voltage vs. Ambient Temperature

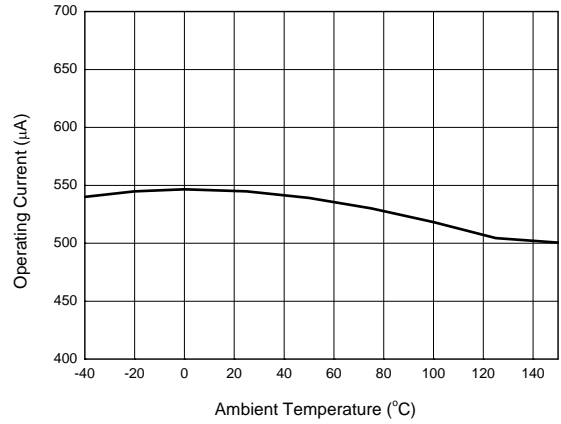

Figure 13. Operating Current vs. Ambient Temperature

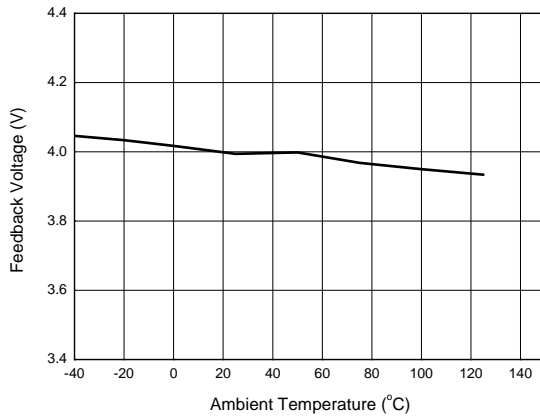

Figure 14. Feedback Voltage vs. Ambient Temperature

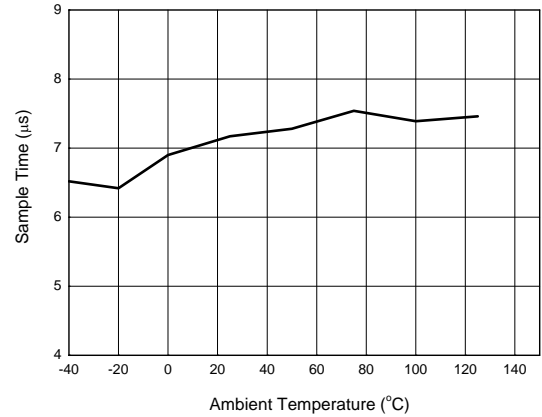

Figure 15. Sample Time vs. Ambient Temperature

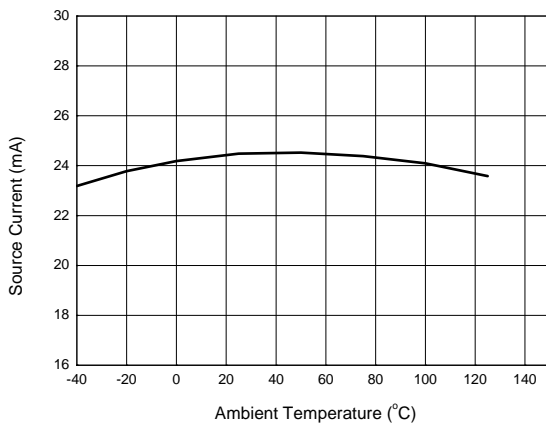

Figure 16. Source Current vs. Ambient Temperature

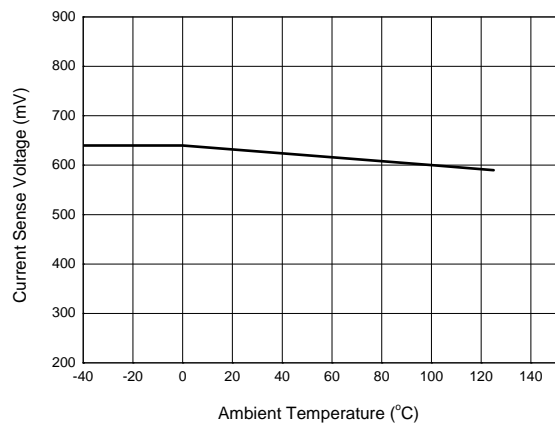

Figure 17. Current Sense Voltage vs. Ambient Temperature

**Performance Characteristics (Cont.)**

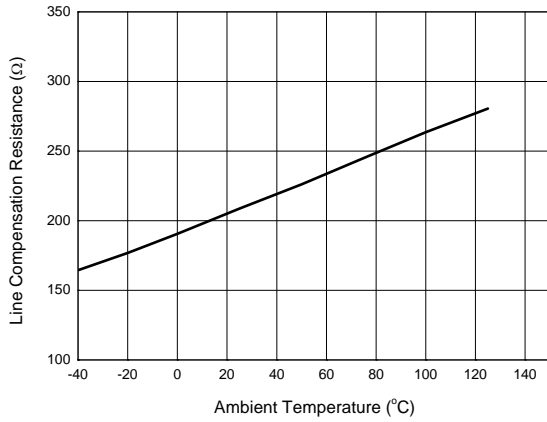

Figure 18. Line Compensation Resistance vs. Ambient Temperature

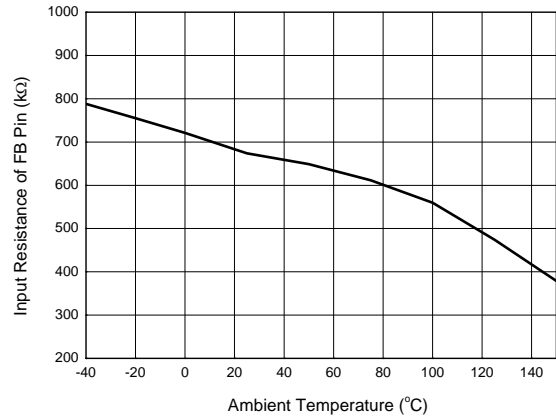
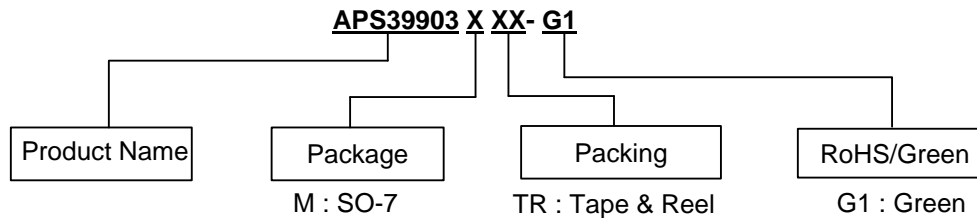

Figure 19. Input Resistance of FB Pin vs. Ambient Temperature

**Ordering Information**



Package	Temperature Range	Cable Compensation Voltage	Part Number	Marking ID	Packing
SO-7	-40 to +150°C	6%	APS39903MTR-G1	39903M-G1	4000/Tape & Reel

**Marking Information**

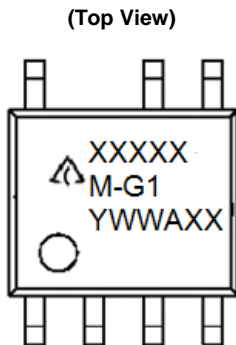

: Logo  
 XXXXXM-G1: Marking ID  
 Third Line: Date Code  
 Y: Year  
 WW: Work Week of Molding  
 A: Assembly House Code  
 XX: 7th and 8th Digits of Batch No.

**Package Outline Dimensions** (All dimensions in mm(inch).)

(1) Package Type: SO-7

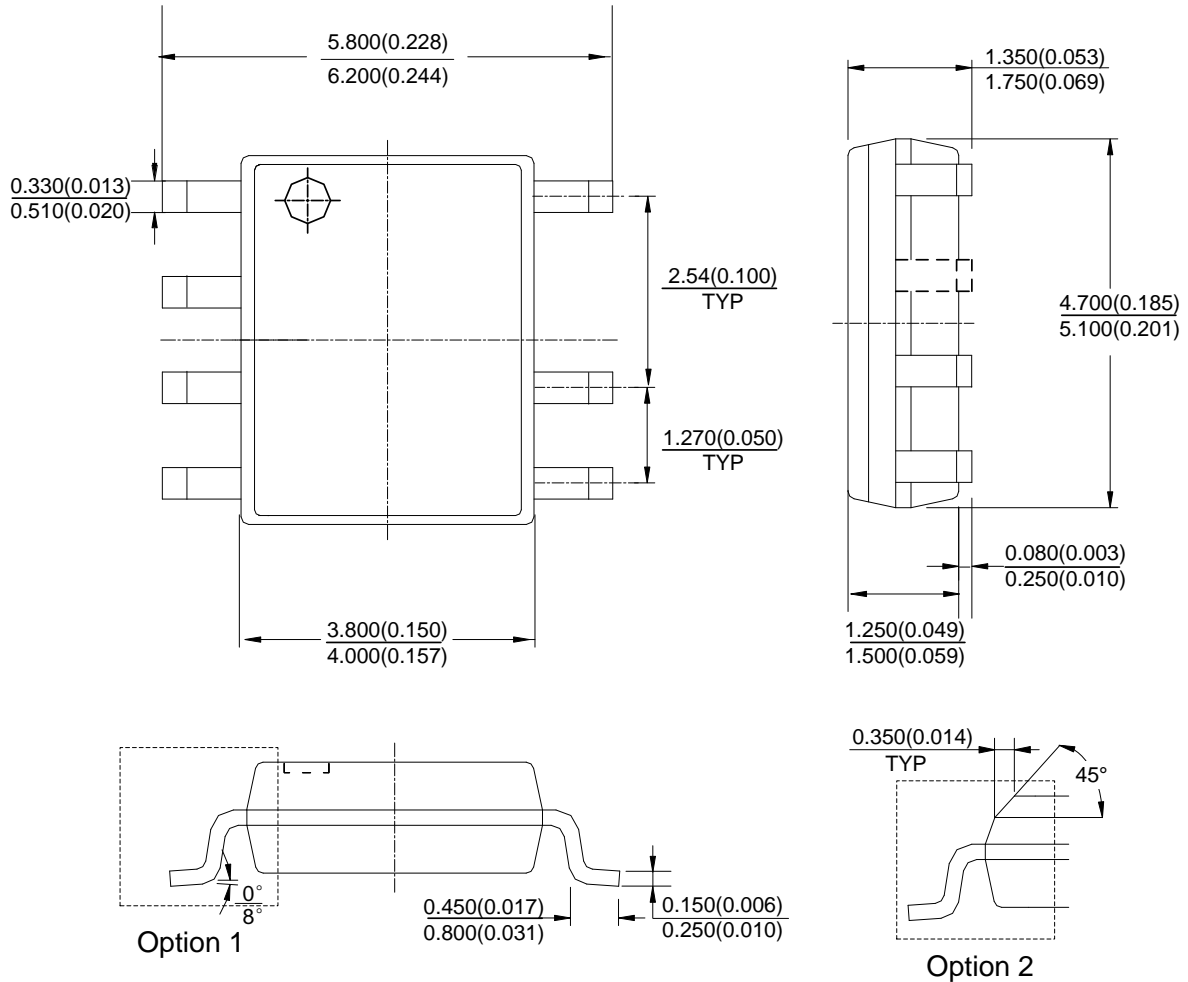

Note: Eject hole, oriented hole and mold mark is optional.

NEW PRODUCT

**Suggested Pad Layout**

(1) Package Type: SO-7

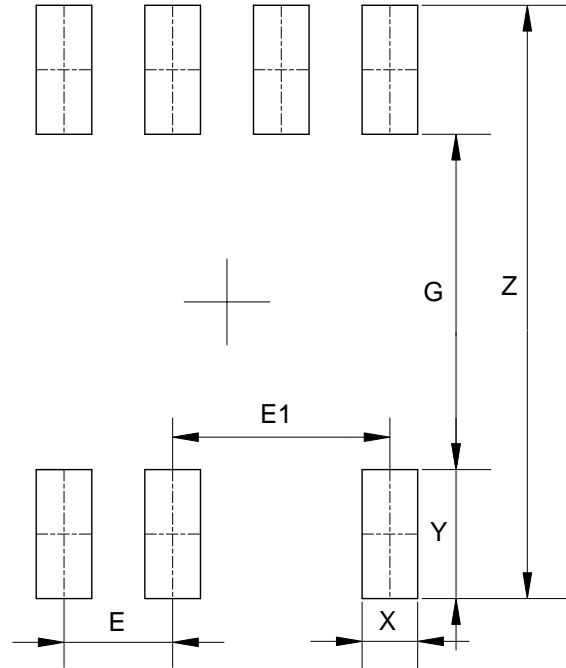

Dimensions	Z (mm)/(inch)	G (mm)/(inch)	X (mm)/(inch)	Y (mm)/(inch)	E (mm)/(inch)	E1 (mm)/(inch)
Value	6.900/0.272	3.900/0.154	0.650/0.026	1.500/0.059	1.270/0.050	2.540/0.100

NEW PRODUCT



#### IMPORTANT NOTICE

DIODES INCORPORATED MAKES NO WARRANTY OF ANY KIND, EXPRESS OR IMPLIED, WITH REGARDS TO THIS DOCUMENT, INCLUDING, BUT NOT LIMITED TO, THE IMPLIED WARRANTIES OF MERCHANTABILITY AND FITNESS FOR A PARTICULAR PURPOSE (AND THEIR EQUIVALENTS UNDER THE LAWS OF ANY JURISDICTION).

Diodes Incorporated and its subsidiaries reserve the right to make modifications, enhancements, improvements, corrections or other changes without further notice to this document and any product described herein. Diodes Incorporated does not assume any liability arising out of the application or use of this document or any product described herein; neither does Diodes Incorporated convey any license under its patent or trademark rights, nor the rights of others. Any Customer or user of this document or products described herein in such applications shall assume all risks of such use and will agree to hold Diodes Incorporated and all the companies whose products are represented on Diodes Incorporated website, harmless against all damages.

Diodes Incorporated does not warrant or accept any liability whatsoever in respect of any products purchased through unauthorized sales channel. Should Customers purchase or use Diodes Incorporated products for any unintended or unauthorized application, Customers shall indemnify and hold Diodes Incorporated and its representatives harmless against all claims, damages, expenses, and attorney fees arising out of, directly or indirectly, any claim of personal injury or death associated with such unintended or unauthorized application.

Products described herein may be covered by one or more United States, international or foreign patents pending. Product names and markings noted herein may also be covered by one or more United States, international or foreign trademarks.

This document is written in English but may be translated into multiple languages for reference. Only the English version of this document is the final and determinative format released by Diodes Incorporated.

#### LIFE SUPPORT

Diodes Incorporated products are specifically not authorized for use as critical components in life support devices or systems without the express written approval of the Chief Executive Officer of Diodes Incorporated. As used herein:

A. Life support devices or systems are devices or systems which:

1. are intended to implant into the body, or
2. support or sustain life and whose failure to perform when properly used in accordance with instructions for use provided in the labeling can be reasonably expected to result in significant injury to the user.

B. A critical component is any component in a life support device or system whose failure to perform can be reasonably expected to cause the failure of the life support device or to affect its safety or effectiveness.

Customers represent that they have all necessary expertise in the safety and regulatory ramifications of their life support devices or systems, and acknowledge and agree that they are solely responsible for all legal, regulatory and safety-related requirements concerning their products and any use of Diodes Incorporated products in such safety-critical, life support devices or systems, notwithstanding any devices- or systems-related information or support that may be provided by Diodes Incorporated. Further, Customers must fully indemnify Diodes Incorporated and its representatives against any damages arising out of the use of Diodes Incorporated products in such safety-critical, life support devices or systems.

Copyright © 2014, Diodes Incorporated

[www.diodes.com](http://www.diodes.com)