



Features

- Close responsively to the human eye spectrum
- Light to Current, Analog output
- Operating Temperature : -40 °C ~ +85 °C
- Supply Voltage : 2.5 V~ 5.5 V
- Package Size : 1.7mm(L)*0.8mm(W)*0.6mm(H)
- RoHS compliant, Pb Free

Applications

- TFT LCD TV, plasma TV
- Mobile devices – mobile phones, PDAs
- Toys

Description

The APTP1708T06 is NPN silicon Phototransistor in SMD type. The spectral response of the ambient light sensor is close to human eyes.

Package Outline

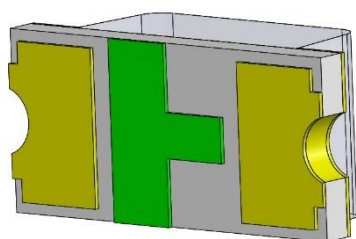
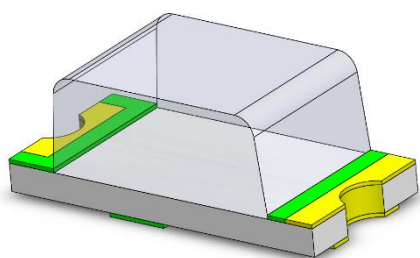

Emitter

Collector

Schematic

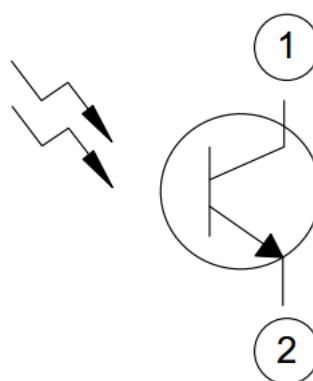

① Collector

② Emitter

**Absolute Maximum Rating at 25°C**

Symbol	Parameters	Ratings	Units	Notes
V _{CC}	Supply Voltage	-0.5 ~ 6.0	V	
T _{opr}	Operating Temperature	-40 ~ +85	°C	
T _{stg}	Storage Temperature	-40 ~ +100	°C	
T _{sol}	Soldering Temperature	260 ±10	°C	2

Recommended Operating Conditions at 25°C

Symbol	Parameters	Ratings	Units	Notes
T _{opr}	Operating Temperature	-40 ~ +85	°C	
V _{CC}	Supply Voltage	2.5 ~ 5.5	V	

**Electrical and Optical Characteristics** $T_A = 25^\circ\text{C}$ (unless otherwise specified)

Symbol	Parameters	Test Conditions	Min	Typ	Max	Units	Notes
I_{CEO}	Dark Current	$V_{CE}=10\text{V}$, $E_v=0$ Lux	-	-	100	nA	
$V_{CE(sat)}$	Collector-Emitter Saturation Voltage	$E_v=1000\text{Lux}$ $I_C=2\text{mA}$	-	-	0.4	V	
I_{PH1}	Light Current	$V_{CE}=5\text{V}$, $E_v=100$ Lux	5	15	-	μA	1
I_{PH2}		$V_{CE}=5\text{V}$, $E_v=1000$ Lux	50	150	-	μA	
I_{PH3}		$V_{CE}=5\text{V}$, $E_v=1000$ Lux	140	520	-	μA	2
I_{PH3} / I_{PH2}	Photocurrent Ratio	$V_{CE}=5\text{V}$, $E_v=1000$ Lux	-	3.5	-		
V_O	Saturation Output Voltage	$V_{CC}=5\text{V}$, $E_v=1000$ Lux $R_L=75\text{K}$	4.5	4.6	-	V	2
λ	Spectral Bandwidth	-	390	-	700	nm	
λ_P	Peak Sensitivity	-	-	630	-	nm	
t_r	Rise time	$V_{CC}=5\text{V}$, $R_L=75\text{K}\Omega$	-	0.11	-	ms	
t_f	Fall time		-	0.22	-	ms	

Notes:

1 : White Fluorescent light (Color Temperature = 6500K) is used as light source.

2 : Illuminance by CIE standard illuminant-A / 2856K, incandescent lamp.



Typical Characteristic Curves

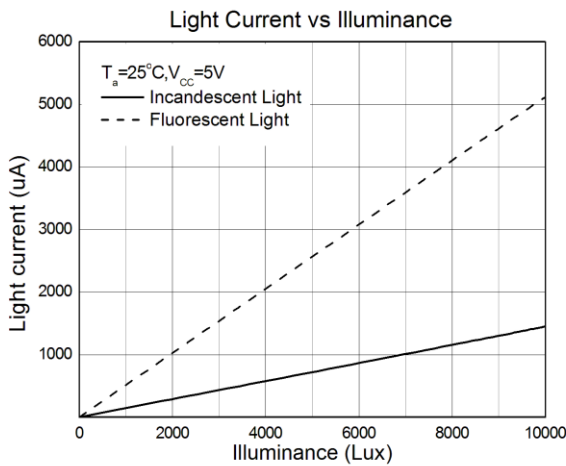

Figure 1

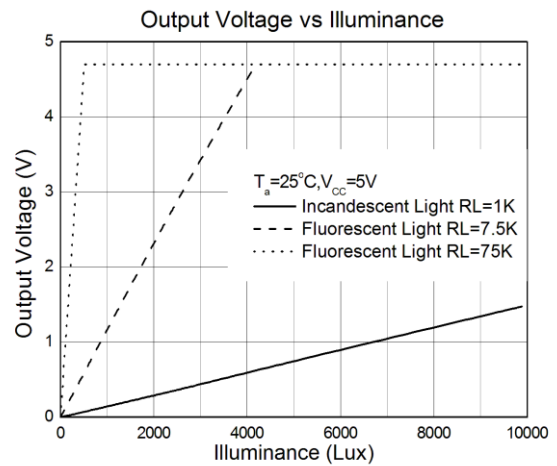

Figure 2

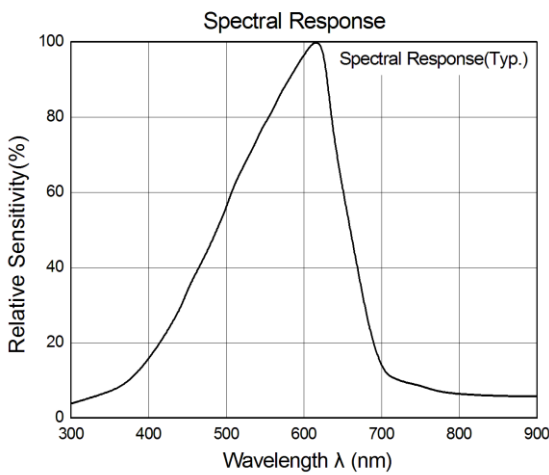

Figure 3

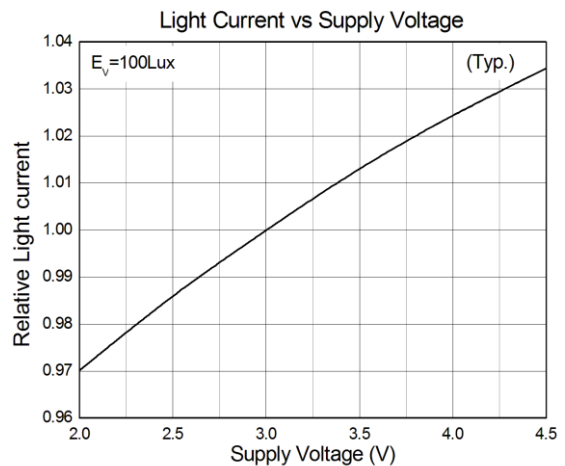

Figure 4

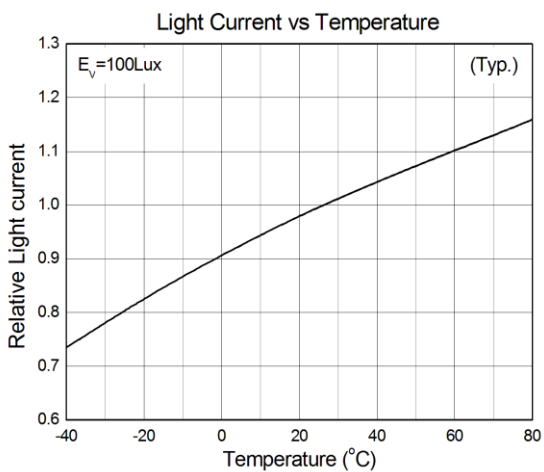

Figure 5

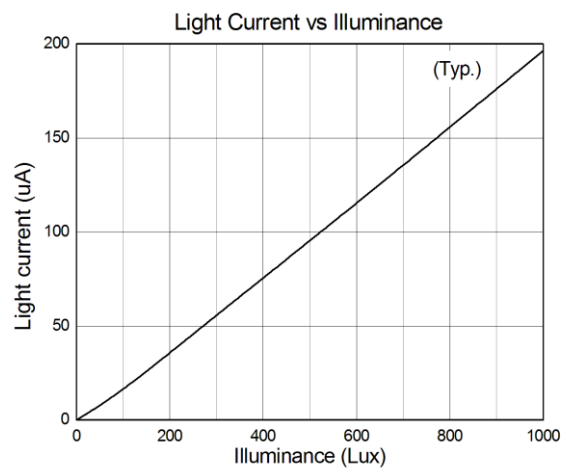
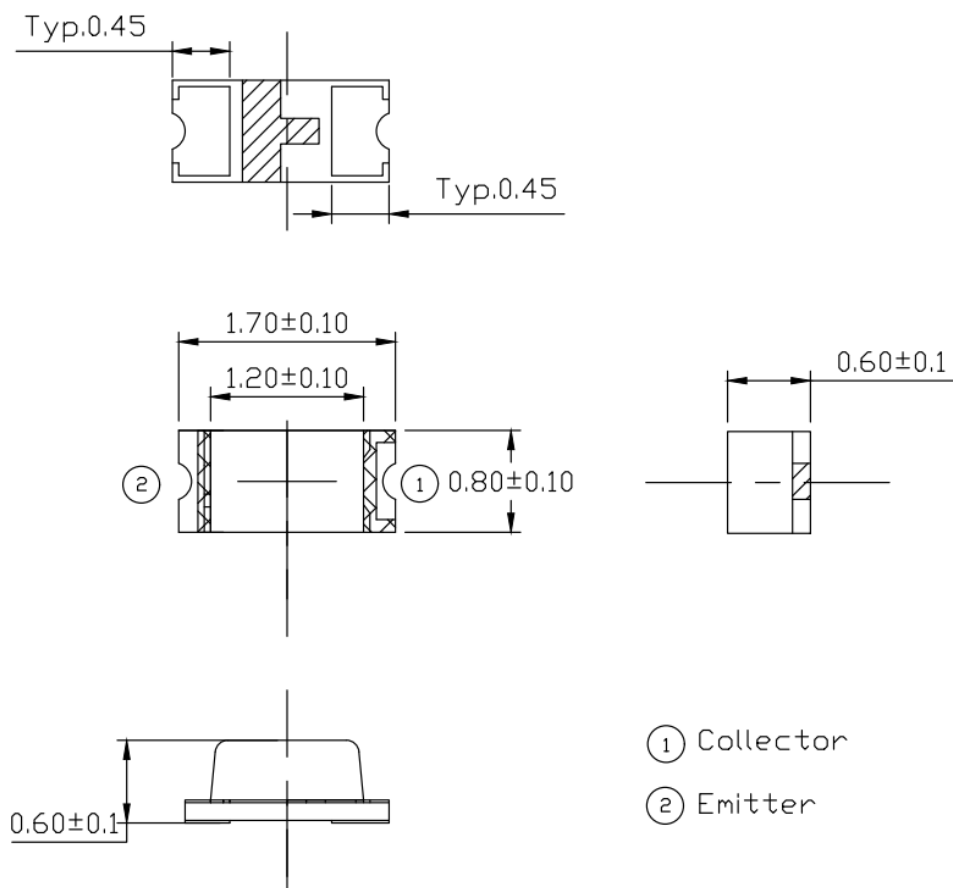

Figure 6



Package Dimension *All dimensions are in mm, unless otherwise stated.*



Recommended Soldering Mask *All dimensions are in mm, unless otherwise state*

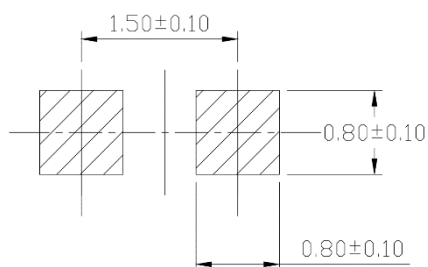

Ordering Information

Part Number	Description	Quantity
APTP1708T06	Tape & Reel	4000 pcs



Reel Dimension *All dimensions are in mm, unless otherwise stated*

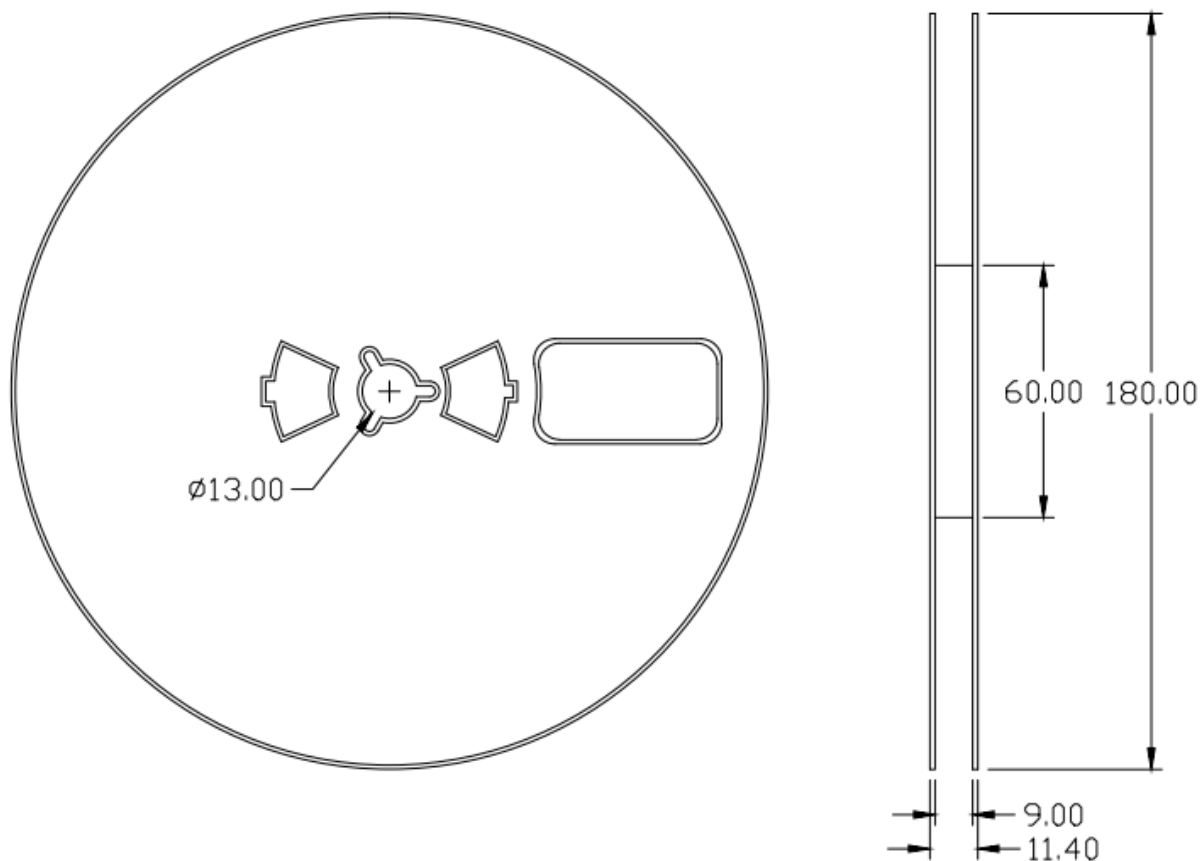

Tape Dimension *All dimensions are in mm, unless otherwise stated*

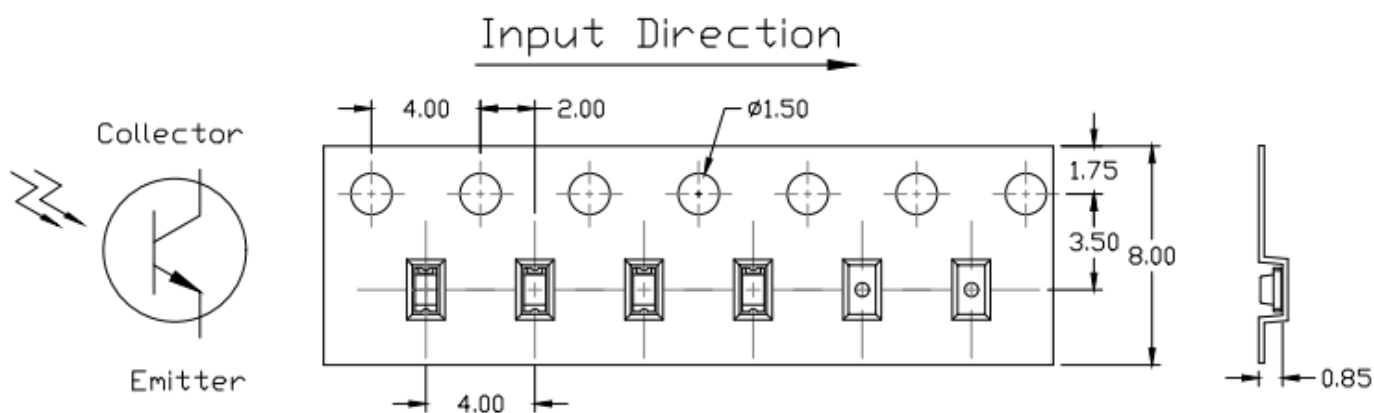



Label Form Specification

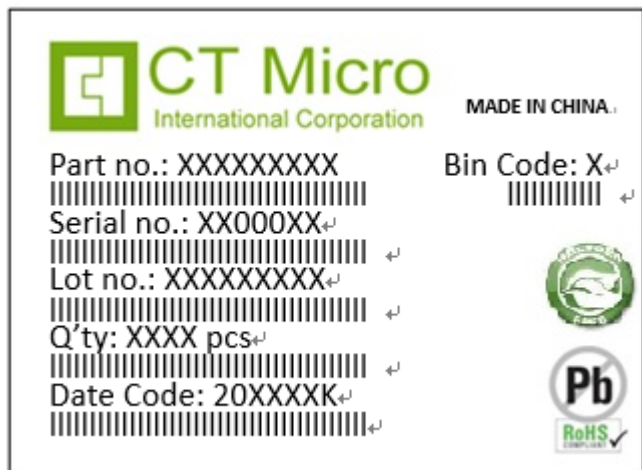

Part no: CTM Production Number
 Serial no: Production Number
 Lot no: Lot number
 Q'ty: Packing Quantity
 Date Code: Manufacture Date
 Bin Code: I_{PH} Ranks
 MADE IN CHINA: Production Place

Storage Condition

1. Do not open moisture proof bag before the products are ready to use.
2. The moisture barrier bag should be stored at 30°C and 90%R.H. max. before opening.
Shelf life of non-opened bag is 12 months after the bag sealing date.
3. After opening the moisture barrier bag floor life is 168h at 30°C/60%RH. max. Unused LEDs should be resealed into moisture barrier bag. (Refer to J-STD-020 Standard)
4. If the moisture absorbent material has faded away or the LEDs have exceeded the storage time, baking treatment should be performed using the J-STD-033 Standard conditions.



Reflow Profile

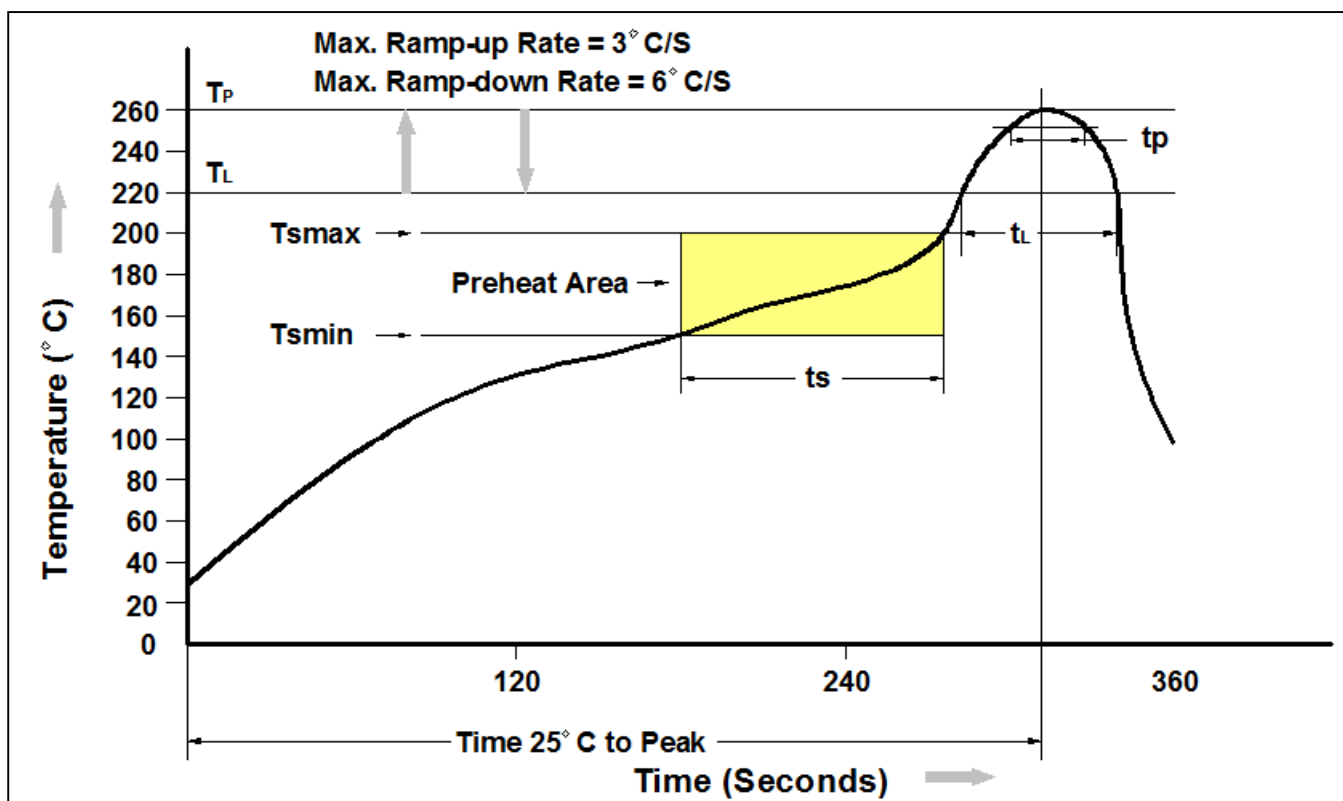

Profile Feature	Pb-Free Assembly Profile
Temperature Min. (Tsmin)	150°C
Temperature Max. (Tsmax)	200°C
Time (ts) from (Tsmin to Tsmax)	60-120 seconds
Ramp-up Rate (tL to tp)	3°C/second max.
Liquidous Temperature (TL)	217°C
Time (tL) Maintained Above (TL)	60 – 150 seconds
Peak Body Package Temperature	260°C +0°C / -5°C
Time (tp) within 5°C of 260°C	30 seconds
Ramp-down Rate (TP to TL)	6°C/second max
Time 25°C to Peak Temperature	8 minutes max.



DISCLAIMER

CT MICRO RESERVES THE RIGHT TO MAKE CHANGES WITHOUT FURTHER NOTICE TO ANY PRODUCTS HEREIN TO IMPROVE RELIABILITY, FUNCTION OR DESIGN. CT MICRO DOES NOT ASSUME ANY LIABILITY ARISING OUT OF THE APPLICATION OR USE OF ANY PRODUCT OR CIRCUIT DESCRIBED HEREIN; NEITHER DOES IT CONVEY ANY LICENSE UNDER ITS PATENT RIGHTS, NOR THE RIGHTS OF OTHERS.

CT MICRO ARE NOT AUTHORIZED FOR USE AS CRITICAL COMPONENTS IN LIFE SUPPORT DEVICES OR SYSTEMS WITHOUT EXPRESS WRITTEN APPROVAL OF CT MICRO INTERNATIONAL CORPORATION.

- 1. Life support devices or systems are devices or systems which, (a) are intended for surgical implant into the body, or (b) support or sustain life, or (c) whose failure to perform when properly used in accordance with instruction for use provided in the labelling, can be reasonably expected to result in significant injury to the user.*
- 2. A critical component is any component of a life support device or system whose failure to perform can be reasonably expected to cause the failure of the life support device or system, or to affect its safety or effectiveness.*