

Features

- 600mA Output Current on Each Channel
- 2.5V to 5.5V Input Voltage Range
- 1.5MHz Constant Frequency Operation
- Low Dropout Operation at 100% Duty Cycle
- Synchronous Topology
- 0.6V Low Reference Voltage
- Typically 0.1 μ A Shutdown Current
- Current Mode Operation
- Over Temperature Protection
- Over Current Protection
- Up to 94% Efficiency
- Internally Compensated
- Lead Free Available (RoHS Compliant)

General Description

The APW7134 contains two independent 1.5MHz constant frequency, current mode, PWM step-down converters. Each converter integrates a main switch and a synchronous rectifier for high efficiency without an external Schottky diode. The APW7134 is ideal for powering portable equipment that runs from a single cell Lithium-Ion (Li+) battery. Each converter can supply 600mA of load current from a 2.5V to 5.5V input voltage. The output voltage can be regulated as low as 0.6V. The APW7134 can also run at 100% duty cycle for low dropout applications.

Pinouts

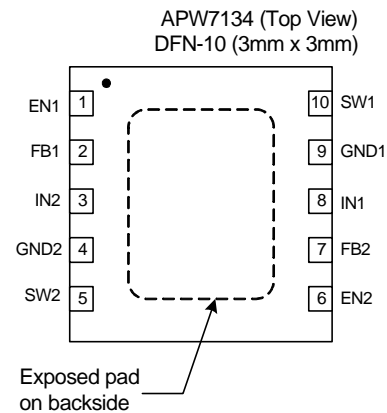

Applications

- TV Tuner/Box
- Portable Instrument

ANPEC reserves the right to make changes to improve reliability or manufacturability without notice, and advise customers to obtain the latest version of relevant information to verify before placing orders.

Ordering and Marking Information

<p>APW7134 □□□-□□□</p> <p> □□□ - Lead Free Code □□□ - Handling Code □□□ - Temp. Range □□□ - Package Code </p>	<p>Package Code QA : DFN-10</p> <p>Temp. Range I : -40 to 85° C</p> <p>Handling Code TU : Tube TR : Tape & Reel</p> <p>Lead Free Code L : Lead Free Device Blank : Original Device</p>	
<p>APW7134 QA: <table border="1" style="display: inline-table; vertical-align: middle;"> <tr> <td style="padding: 2px;">APW 7134 XXXXX</td> </tr> </table> XXXXX - Date Code</p>	APW 7134 XXXXX	
APW 7134 XXXXX		

Note: ANPEC lead-free products contain molding compounds/die attach materials and 100% matte tin plate termination finish; which are fully compliant with RoHS and compatible with both SnPb and lead-free soldering operations. ANPEC lead-free products meet or exceed the lead-free requirements of IPC/JEDEC J STD-020C for MSL classification at lead-free peak reflow temperature.

Block Diagram

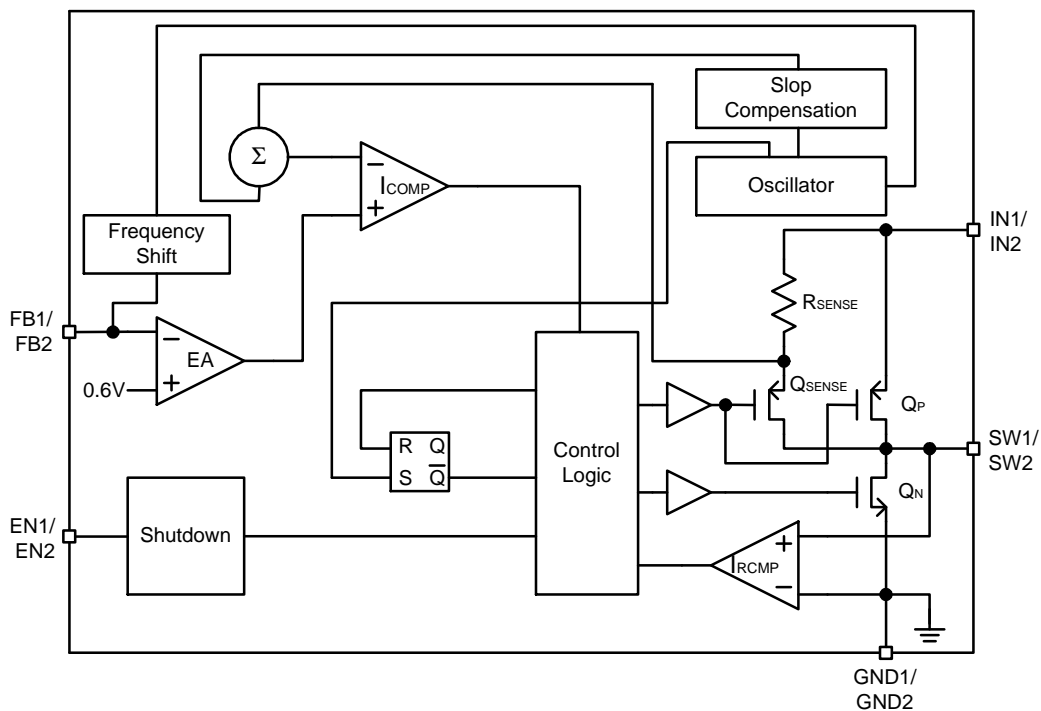

Diagram Represents 1/2 of the APW7134

Pin Description

Pin No.	Name	Function
1	EN1	Channel 1 Enable Control Input. Drive EN1 above 1.5V to turn on the Channel 1. Drive EN1 below 0.3V to turn it off. In shutdown situation, all functions are disabled to decrease the supply current below 1 μ A. There is no pull high or pull low ability inside.
2	FB1	Channel 1 Feedback Input. Connect FB1 to the center point of the external resistor divider. The feedback voltage is 0.6V.
3	IN2	Channel 2 Supply Input. Bypass to GND with a 4.7 μ F or greater ceramic capacitor.
4	GND2	Ground 2. Connected the exposed pad to GND2.
5	SW2	Channel 2 Power Switch Output. Inductor connection to drains of the internal PMOSFET and NMOSFET switches.
6	EN2	Channel 2 Enable Control Input. Drive EN2 above 1.5V to turn on the Channel 2. Drive EN2 below 0.3V to turn it off. In shutdown situation, all functions are disabled to decrease the supply current below 1 μ A. There is no pull high or pull low ability inside.
7	FB2	Channel 2 Feedback Input. Connect FB2 to the center point of the external resistor divider. The feedback voltage is 0.6V.
8	IN1	Channel 1 Supply Input. Bypass to GND with a 4.7 μ F or greater ceramic capacitor.
9	GND1	Ground 1. Connected the exposed pad to GND1.
10	SW1	Channel 1 Power Switch Output. Inductor connection to drains of the internal PMOSFET and NMOSFET switches.

Absolute Maximum Ratings

Symbol	Parameter	Value	Unit
V _{IN1/IN2}	Input Supply Voltage (IN1/IN2 to GND1/GND2)	-0.3 ~ 6	V
V _{FB1/FB2}	Voltage on FB1 and FB2	-0.3 ~ V _{IN1/IN2} +0.3	V
V _{EN1/EN2}	Voltage on EN1 and EN2	-0.3 ~ V _{IN1/IN2} +0.3	V
V _{SW1/SW2}	Voltage on SW1 and SW2	-0.3 ~ V _{IN1/IN2} +0.3	V
I _{SW_PEAK}	Peak SW Current	1.3	A
T _J	Junction temperature	150	°C
T _{STG}	Storage temperature	-65 ~ 150	°C
T _{SDR}	Soldering temperature, 10 seconds	300	°C
V _{ESD}	Minimum ESD rating (Human body mode) (Note 1)	±3	KV

Note 1: The device is ESD sensitive. Handling precautions are recommended.

Thermal Characteristics

Symbol	Parameter	Value	Unit
θ_{JA}	Junction-to-Ambient Resistance in free air (Note 2)	50	°C/W

Note 2: θ_{JA} is measured on approximately 1" square of 1 oz copper.

Recommended Operating Conditions (Note 3)

Symbol	Parameter	Value			Unit
		Min.	Typ.	Max.	
V _{IN1/IN2}	Input Supply Voltage (IN1/IN2 to GND1/GND2)	2.5		5.5	V
R2/R4	Feedback Resistance (Note 3)			200	KΩ
I _{OUT}	Output Current			600	mA
T _A	Operating ambient temperature	-40		85	°C
T _J	Operating junction temperature	-40		125	°C

Note 3: Please refer to the typical application circuit.

Electrical Characteristics

The * denotes the specifications that apply over T_A = -40°C ~ 85°C, otherwise specifications are at T_A = 25°C

Symbol	Parameter	Test Conditions	APW7134			Unit
			Min.	Typ.	Max.	
V _{IN1/IN2}	Each Converter Input Voltage Range		* 2.5		5.5	V
I _{FB1/FB2}	Each Converter Feedback current	V _{FB1/FB2} = 0.6V	* -30		30	nA
V _{FB1/FB2}	Each Converter Regulated Feedback Voltage		* 0.588	0.6	0.612	V
ΔV _{FB1/FB2}	Each Converter Reference voltage Line regulation	V _{IN1/IN2} = 2.5V to 5.5V	*	0.04	0.4	%V
I _{PK}	Each Converter Peak Inductor Current	V _{IN1/IN2} = 3V, V _{FB} = 0.5V or V _{OUT} = 90%, Duty cycle < 35%	0.75	1	1.25	A
V _{LOADR}	Each Converter Load Regulation			0.5		%
I _Q	Each Converter Quiescent Current	Duty Cycle = 0; V _{FB} = 1.5V		300	400	μA

Electrical Characteristics (Cont.)

The * denotes the specifications that apply over $T_A = -40^{\circ}\text{C} \sim 85^{\circ}\text{C}$, otherwise specifications are at $T_A = 25^{\circ}\text{C}$

Symbol	Parameter	Test Conditions	APW7134			Unit
			Min.	Typ.	Max.	
I_{Q-SD}	Each Converter Quiescent Current in Shutdown	$V_{EN1/EN2}=0V, V_{IN}=4.2V$		0.1	1	μA
f_{OSC}	Each Converter Oscillator Frequency	$V_{FB}=0.6V$	1.2	1.5	1.8	MHz
f_{OSC_FFB}	Each Converter Frequency Foldback	$V_{FB}=0V$		210		KHz
R_{DS-P}	Each Converter On Resistance of PMOSFET	$I_{SW}=100\text{mA}$		0.4	0.5	Ω
R_{DS-N}	Each Converter On Resistance of NMOSFET	$I_{SW}=-100\text{mA}$		0.35	0.45	Ω
I_{LSW}	Each Converter SW Leakage Current	$V_{EN1}=0V, V_{SW}=0V$ or $5V, V_{IN}=5V$		± 0.01	± 1	μA
$V_{EN1/EN2}$	Each Converter Enable Threshold		* 0.3	1	1.5	V
$I_{EN1/EN2}$	EN1/EN2 Leakage Current		*	± 0.01	± 1	μA

Application Circuit

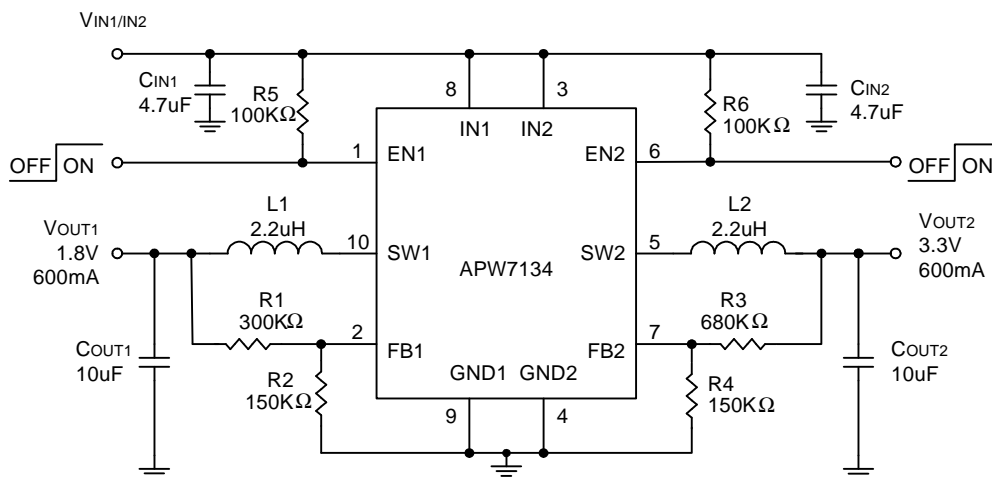

Typical Application

Typical Operating Characteristics

Reference Voltage

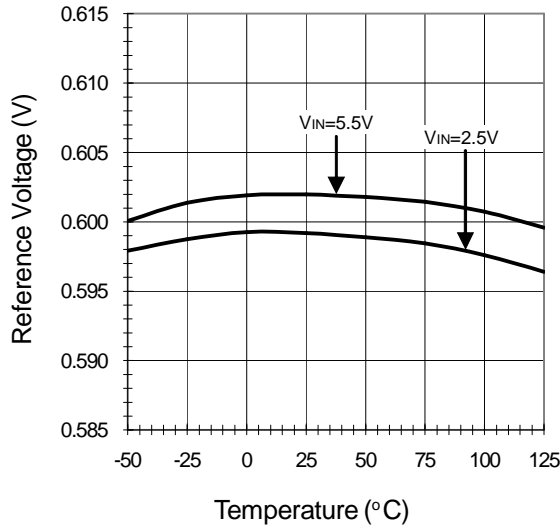

Oscillator Frequency

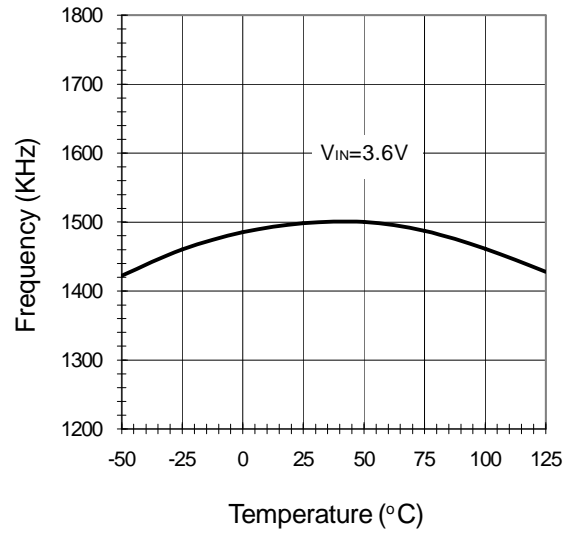

Oscillator Frequency vs Supply Voltage

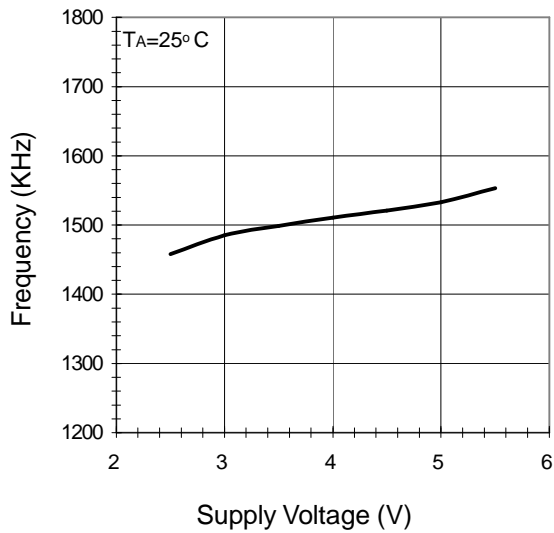

$R_{DS(ON)}$ vs Temperature

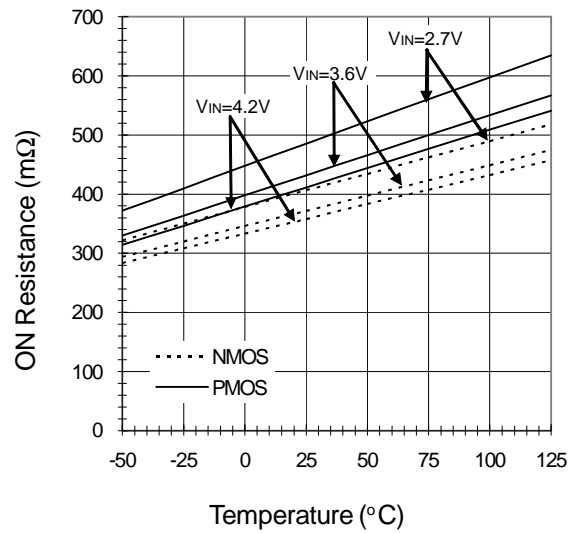

Typical Operating Characteristics (Cont.)

$R_{DS(ON)}$ vs Input Voltage

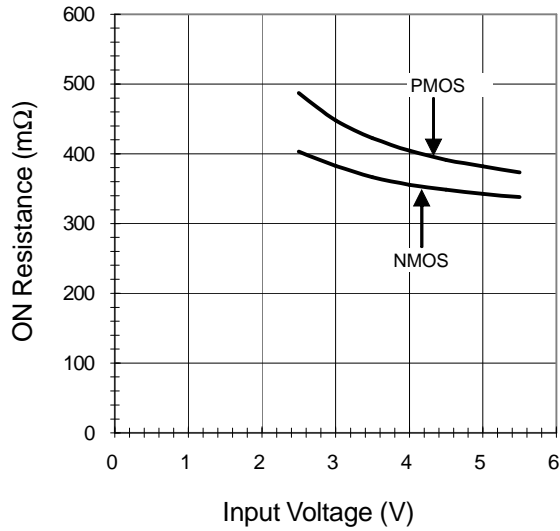

Efficiency vs Output Current

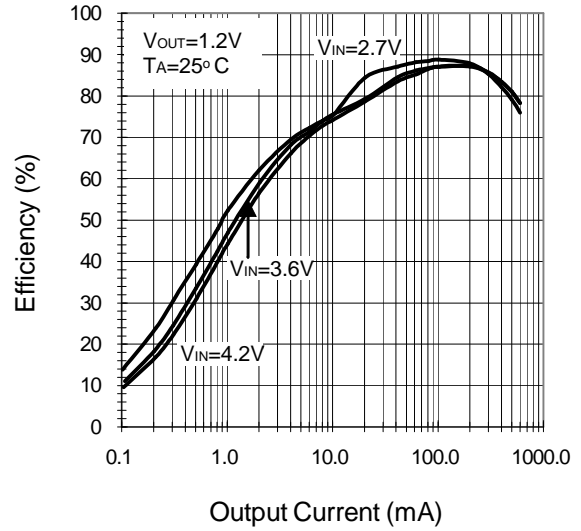

Efficiency vs Output Current

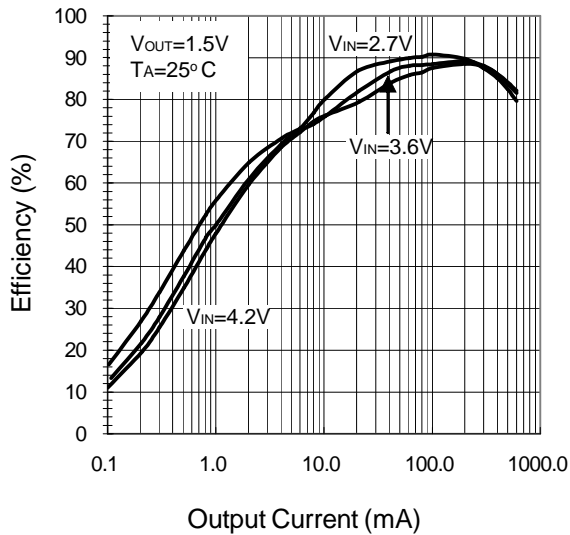

Efficiency vs Output Current

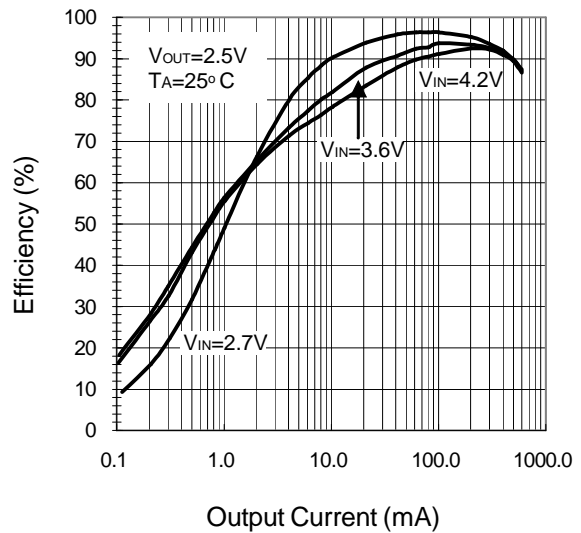

Typical Operating Characteristics (Cont.)

Efficiency vs Input Voltage

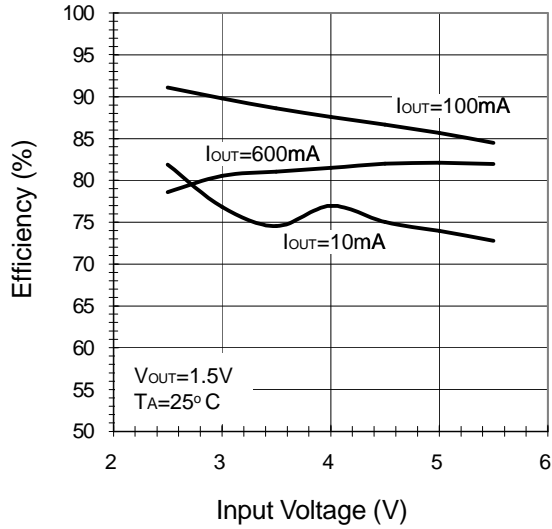

Efficiency vs Input Voltage

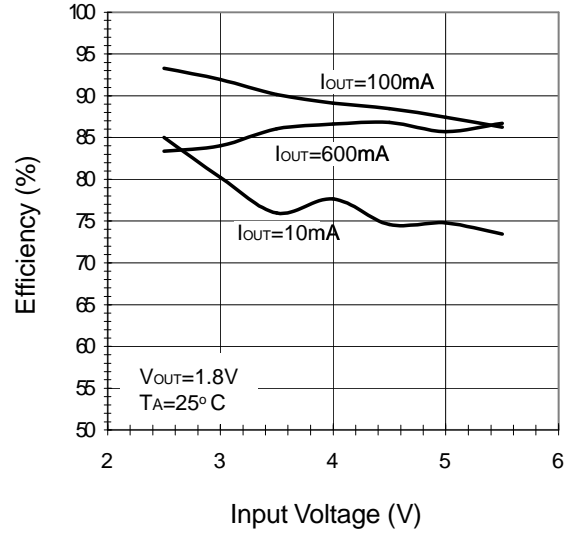

Efficiency vs Input Voltage

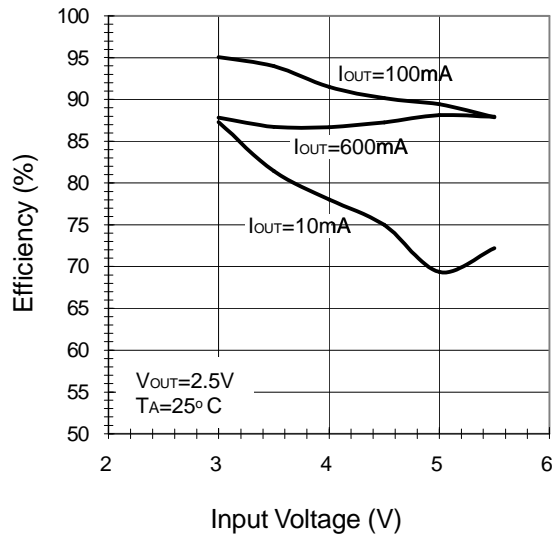

Dynamic Supply Current vs Supply Voltage

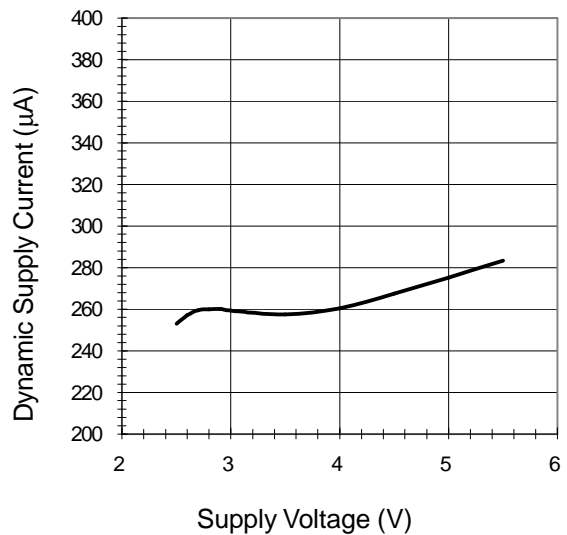

Typical Operating Characteristics (Cont.)

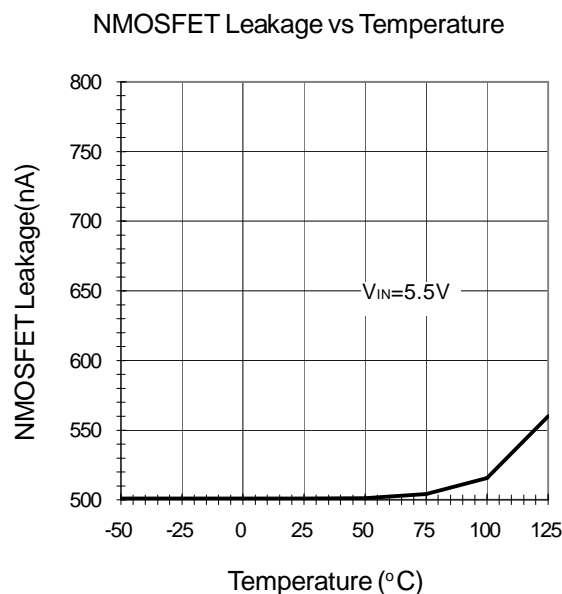
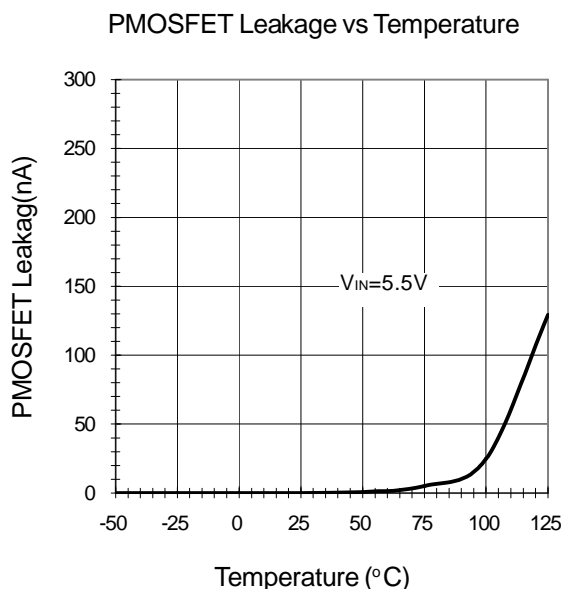

Functional Descriptions

Main Control Loop

The APW7134 has dual independent constant frequency current mode PWM step-down converters. All the main and synchronous switches are internal to reduce the external components. During normal operation, the internal PMOSFET is turned on, but is turned off when the inductor current at the input of I_{COMP} to reset the RS latch. The load current increases, it causes a slight decrease in the feedback voltage, which in turn, causes the EA's output voltage to increase until the average inductor current matches the new load current. While the internal power PMOSFET is off, the internal power NMOSFET is turned on until the inductor current starts to reverse, as indicated by the current reversal comparator I_{RCMP} , or the beginning of next cycle. When the NMOSFET is turned off by I_{RCMP} , it operates in the discontinuous conduction mode.

Pulse Skipping Mode Operation

At light load with a relative small inductance, the inductor current may reach zero. The internal power NMOSFET is turned off by the current reversal comparator, I_{RCMP} , and the switching voltage will ring. This is discontinuous mode operation, and is normal behavior for the switching regulator. At very light load, the APW7134 will automatically skip some pulses in the pulse skipping mode to maintain the output regulation. The skipping process modulates smoothly depend on the load.

Short Circuit Protection

In the short circuit situation, the output voltage is almost zero volts. Output current is limited by the I_{COMP} to prevent the damage of electrical circuit. In the normal operation, the two straight line of the inductor current ripple have the same height, it means the volts-seconds product is the same. When the short circuit operation occurs, the output voltage down to

Functional Descriptions (Cont.)

Short Circuit Protection Cont.

zero leads to the voltage across the inductor maximum in the on period and the voltage across the inductor minimum in the off period. In order to maintain the volts-seconds balance, the off-time must be extended to prevent the inductor current run away. Frequency decay will extend the switching period to provide more times to the off-period, then the inductor current have to restrict to protect the electrical circuit in the short situation.

Dropout Operation

An important detail to remember is that on resistance of PMOSFET switch will increase at low input supply voltage. Therefore, the user should calculate the power dissipation when the APW7134 is used at 100% duty cycle with low input voltage.

Slope Compensation

Slope compensation provides stability in constant frequency current mode architecture by preventing sub-harmonic oscillations at high duty cycle. It is accomplished internally by adding a compensating ramp to the inductor current signal at duty cycle in excess of 40%. Normally, this results in a reduction of maximum inductor peak current for duty cycles greater than 40%. In the APW7134, the reduction of inductor peak current recovered by a special skill at high duty ratio. This allow the maximum inductor peak current maintain a constant level through all duty ratio.

Application Description

Inductor Selection

Due to the high switching frequency as 1.5MHz, the inductor value of the application field of APW7134 is usually from 1 μ H to 4.7 μ H. The criterion to selecting a suitable inductor is dependent on the worst current ripple throughout the inductor. The worst current ripple defines as 40% of the fully load capability. In the APW7134 applications, the worst value of current ripple is 240mA, the 40% of 600mA. Evaluate L by equation (1):

$$L = \frac{(V_{IN} - V_{OUT}) \cdot V_{OUT}}{V_{IN}} \cdot \frac{1}{\Delta I_L \cdot f_s} \quad (1)$$

where f_s is the switching frequency of APW7134 and ΔI_L is the value of the worst current ripple, it can be any value of current ripple that smaller than the worst value you can accept. In order to perform high efficiency,

selecting a low DC resistance inductor is a helpful way. Another important parameter is the DC current rating of the inductor. The minimum value of DC current rating equals the full load value of 600mA, plus the half of the worst current ripple, 120mA. Choose inductors with suitable DC current rating to ensure the inductors don't operate in the saturation.

Input Capacitor Selection

The input capacitor must be able to support the maximum input operating voltage and maximum RMS input current. The Buck converter absorbs current from input in pulses.

Application Description (Cont.)

Input Capacitor Selection Cont.

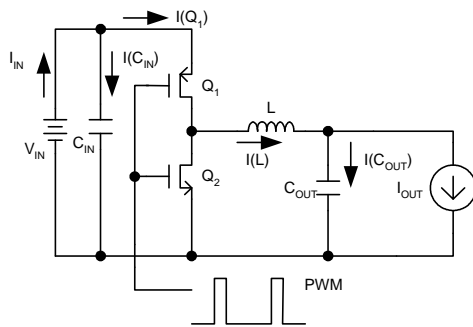

Figure-1

Figure-1 shows a schematic of a Buck structure. The waveforms show as Figure-2.

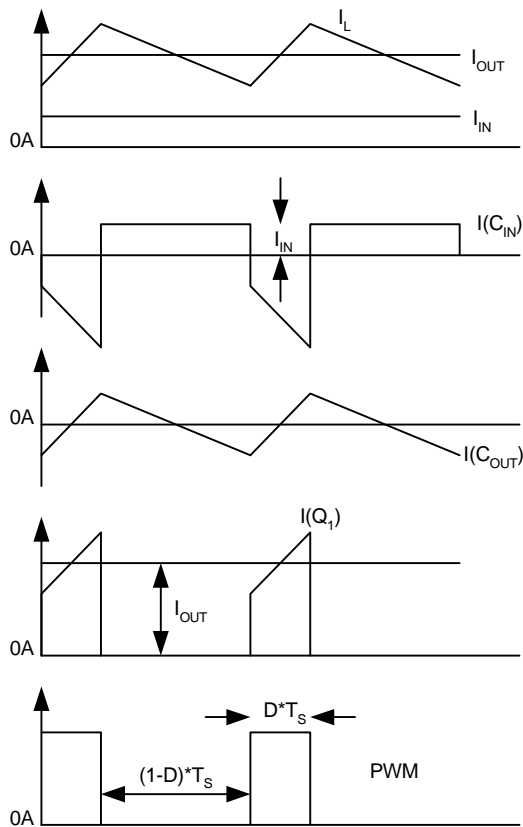

Figure-2

Observe the waveform of $I(C_{IN})$, the RMS value of $I(C_{IN})$ is

$$I(C_{IN}) = \sqrt{[(I_{OUT} - I_{IN})^2 \cdot \sqrt{D}]^2 + [I_{IN} \cdot \sqrt{1-D}]^2} \quad (2)$$

Replace D and I_{IN} by following relation:

$$D = \frac{V_{OUT}}{V_{IN}} \quad (3)$$

$$I_{IN} = D \cdot I_{OUT} \quad (4)$$

The RMS value of input capacitor current equal:

$$I(C_{IN}) = I_{OUT} \cdot \sqrt{D(1-D)} \quad (5)$$

When $D=0.5$ the RMS current of input capacitor will be maximum value. Use this value to choose the input capacitor with suitable current rating.

Output Capacitor Selection

The output voltage ripple is a significant parameter to estimate the performance of a convertor. There are two discrete components that affect the output voltage ripple bigger or smaller. It is recommended to use the criterion has mentioned above to choose a suitable inductor. Then based on this known inductor current ripple condition, the value and properties of output capacitor will affect the output voltage ripple better or worse. The output voltage ripple consists of two portions, one is the product of ESR and inductor current ripple, the other portion is a function of the inductor current ripple and the output capacitance. Figure-3 shows the waveforms to explain the part decided by the output capacitance.

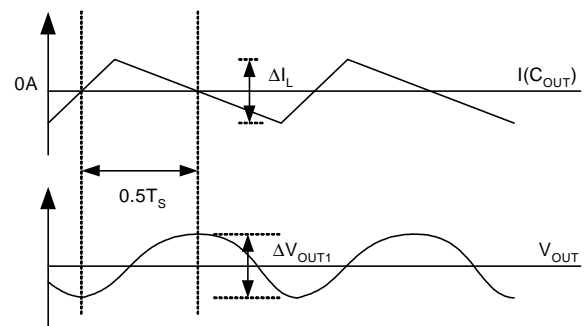

Figure-3

Application Description (Cont.)

Output Capacitor Selection

Evaluate the ΔV_{OUT1} by the ideal of energy equalization. According to the definition of Q,

$$Q = \frac{1}{2} \left(\frac{1}{2} \Delta I_L \cdot \frac{1}{2} T_s \right) = C_{OUT} \cdot \Delta V_{OUT1} \quad (6)$$

where T_s is the inverse of switching frequency and the ΔI_L is the inductor current ripple. Move the C_{OUT} to the left side to estimate the value of ΔV_{OUT1} as equation (7).

$$\Delta V_{OUT1} = \frac{\Delta I_L \cdot T_s}{8 \cdot C_{OUT}} \quad (7)$$

As mentioned above, one part of output voltage ripple is the product of the inductor current ripple and ESR of output capacitor. The equation (8) explains the output voltage ripple estimation.

$$\Delta V_{OUT} = \Delta I_L \cdot \left(ESL + \frac{T_s}{8 \cdot C_{OUT}} \right) \quad (8)$$

Thermal Considerations

APW7134 is a high efficiency switching converter, it means less power loss transferred into heat. Due to the on resistance difference between internal power PMOSFET and NMOSFET, the power dissipation in the high converting ratio is greater than low converting ratio. The worst case is in the dropout operation, the mainly conduction loss dissipate on the internal power PMOSFET. The power dissipation nearly defined as:

$$P_D = (I_{OUT})^2 [R_{DS_ONP} \cdot D + R_{DS_ONN} \cdot (1-D)] \quad (9)$$

APW7134 has internal over temperature protection. When the junction temperature reaches 150 centigrade, APW7134 will turn off both internal power PMOSFET and NMOSFET. The estimation of the junction temperature, T_J , defined as:

$$T_J = P_D \cdot \theta_{JA} \quad (10)$$

where the θ_{JA} is the thermal resistance of the package utilized by APW7134.

Output Voltage Setting

APW7134 has the adjustable version for output voltage setting by the users. A suggestion of maximum value of R_2 is 200K Ω to keep the minimum current that provides enough noise rejection ability through the resistor divider. The output voltage programmed by the equation:

$$V_{OUT} = 0.6 \cdot \left(1 + \frac{R_1}{R_2} \right) \quad (11)$$

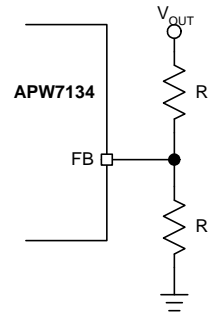

Layout Considerations

The high current paths (GND1/GND2, IN1/IN2 and SW1/SW2) should be placed very close to the device with short, direct and wide traces. Input capacitors should be placed as close as possible to the respective IN and GND pins. The external feedback resistors shall be placed next to the FB pins. Keep the switching nodes SW1/SW2 short and away from the feedback network.

Package Information

DFN-10

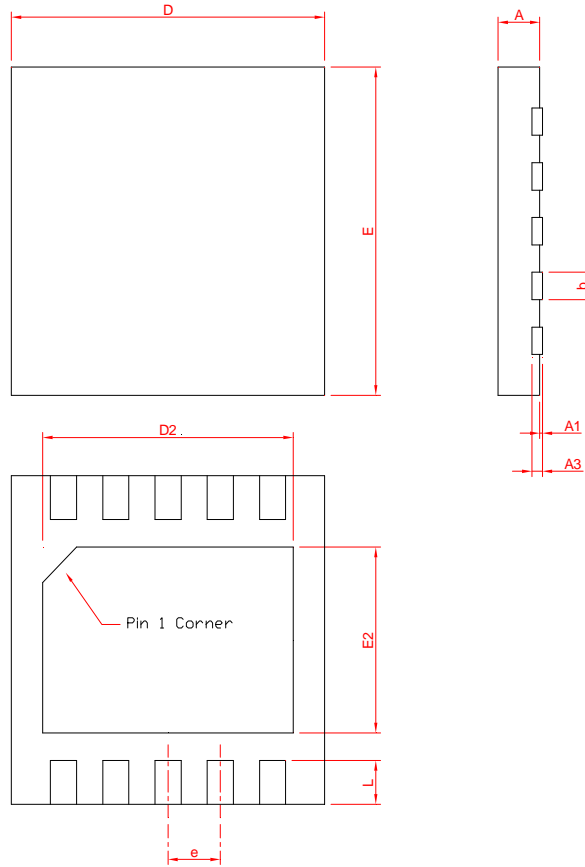

Dim	Millimeters		Inches	
	Min.	Max.	Min.	Max.
A	0.80	1.00	0.031	0.039
A1	0.00	0.05	0.000	0.002
A3	0.20 REF		0.008 REF	
b	0.18	0.30	0.007	0.012
D	3.00 BSC		0.118 BSC	
D2	2.20	2.50	0.087	0.098
E	3.00 BSC		0.118 BSC	
E2	1.50	1.80	0.059	0.071
e	0.50 BSC		0.016 BSC	
L	0.35	0.45	0.014	0.018

Carrier Tape & Reel Dimensions

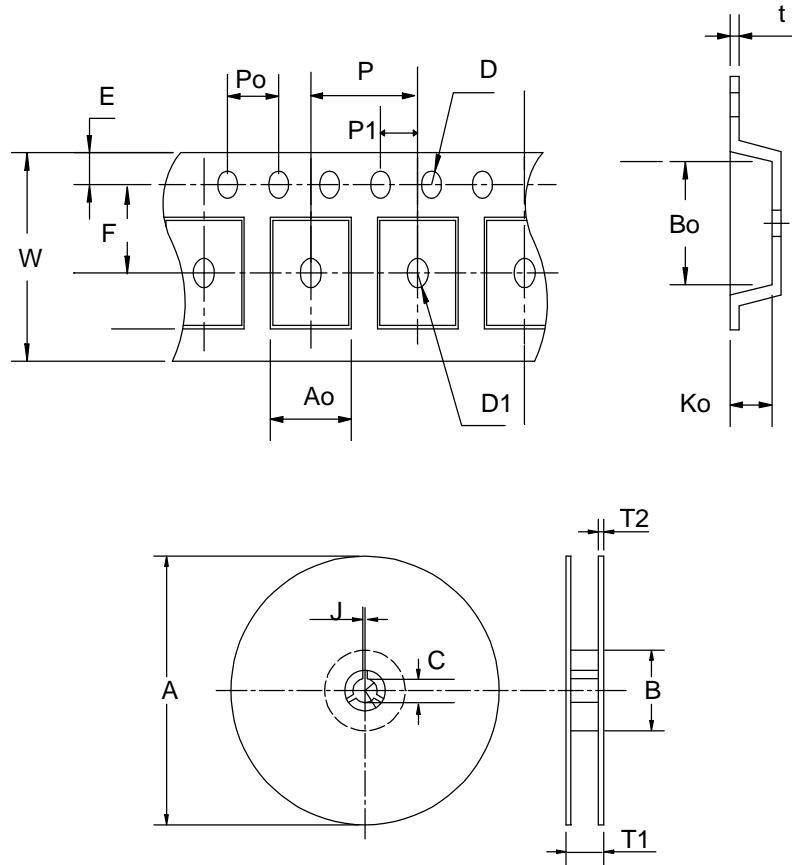

Application	A	B	C	J	T1	T2	W	P	E
DFN-10	178 ± 1	54.4 ± 0.4	13.0 + 0.2	2.3 ± 0.1	12.3 ± 1	1.4 ± 0.5	12 ± 0.3	8.0 ± 0.1	1.75 ± 0.1
	F	D	D1	Po	P1	Ao	Bo	Ko	T
	5.5 ± 0.05	1.5 + 0.1	1.5 + 0.1	4.0 ± 0.1	2.0 ± 0.05	3.3 ± 0.1	3.3 ± 0.1	1.1 ± 0.1	0.3 ± 0.05

(mm)

Cover Tape Dimensions

Application	Carrier Width	Cover Tape Width	Devices Per Reel
DFN-10	12	9.2	3000

Physical Specifications

Terminal Material	Solder-Plated Copper (Solder Material : 90/10 or 63/37 SnPb), 100%Sn
Lead Solderability	Meets EIA Specification RSI86-91, ANSI/J-STD-002 Category 3.

Reflow Condition (IR/Convection or VPR Reflow)

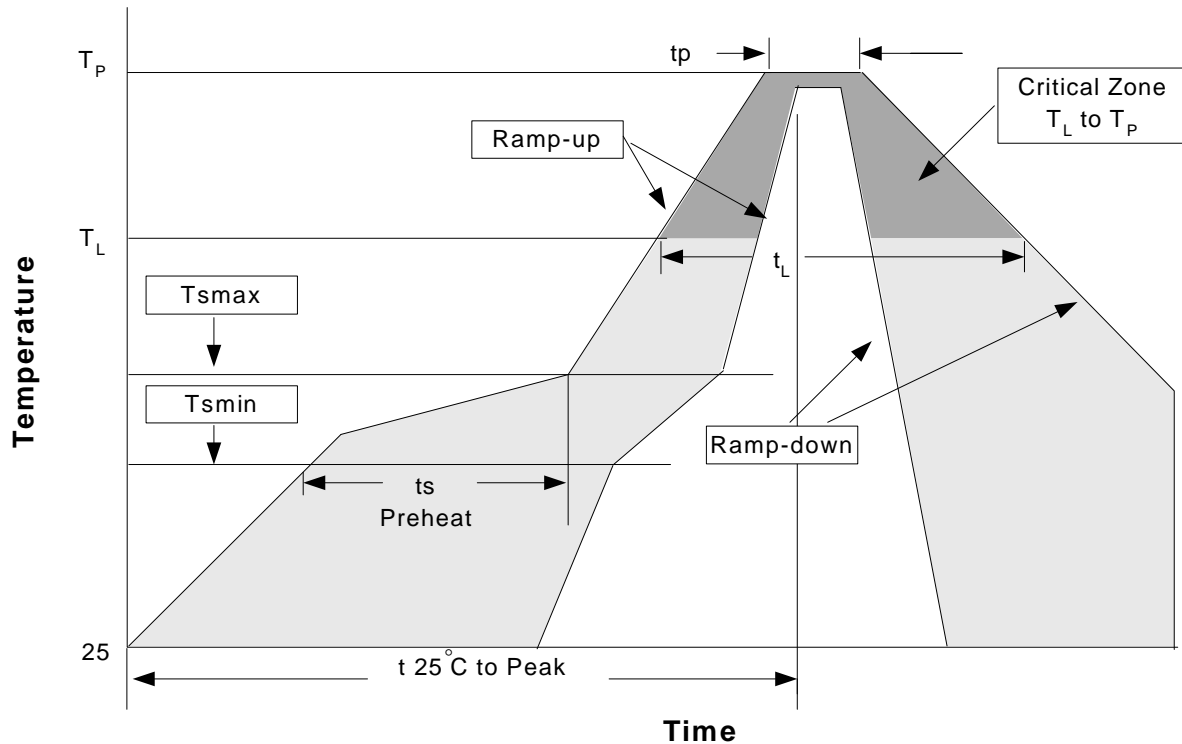

Classification Reflow Profiles

Profile Feature	Sn-Pb Eutectic Assembly	Pb-Free Assembly
Average ramp-up rate (T_L to T_P)	3°C/second max.	3°C/second max.
Preheat		
- Temperature Min (T_{smin})	100°C	150°C
- Temperature Max (T_{smax})	150°C	200°C
- Time (min to max) (t_s)	60-120 seconds	60-180 seconds
Time maintained above:		
- Temperature (T_L)	183°C	217°C
- Time (t_L)	60-150 seconds	60-150 seconds
Peak/Classification Temperature (T_p)	See table 1	See table 2
Time within 5°C of actual Peak Temperature (t_p)	10-30 seconds	20-40 seconds
Ramp-down Rate	6°C/second max.	6°C/second max.
Time 25°C to Peak Temperature	6 minutes max.	8 minutes max.

Notes: All temperatures refer to topside of the package .Measured on the body surface.

Classification Reflow Profiles(Cont.)

Table 1. SnPb Eutectic Process – Package Peak Reflow Temperatures

Package Thickness	Volume mm ³ <350	Volume mm ³ ≥350
<2.5 mm	240 +0/-5°C	225 +0/-5°C
≥2.5 mm	225 +0/-5°C	225 +0/-5°C

Table 2. Pb-free Process – Package Classification Reflow Temperatures

Package Thickness	Volume mm ³ <350	Volume mm ³ 350-2000	Volume mm ³ >2000
<1.6 mm	260 +0°C*	260 +0°C*	260 +0°C*
1.6 mm – 2.5 mm	260 +0°C*	250 +0°C*	245 +0°C*
≥2.5 mm	250 +0°C*	245 +0°C*	245 +0°C*

*Tolerance: The device manufacturer/supplier **shall** assure process compatibility up to and including the stated classification temperature (this means Peak reflow temperature +0°C. For example 260°C+0°C) at the rated MSL level.

Reliability test program

Test item	Method	Description
SOLDERABILITY	MIL-STD-883D-2003	245°C, 5 SEC
HOLT	MIL-STD-883D-1005.7	1000 Hrs Bias @125°C
PCT	JESD-22-B,A102	168 Hrs, 100%RH, 121°C
TST	MIL-STD-883D-1011.9	-65°C~150°C, 200 Cycles
ESD	MIL-STD-883D-3015.7	VHBM > 2KV, VMM > 200V
Latch-Up	JESD 78	10ms, 1 _{tr} > 100mA

Customer Service

Anpec Electronics Corp.

Head Office :

No.6, Dusing 1st Road, SBIP,
Hsin-Chu, Taiwan, R.O.C.
Tel : 886-3-5642000
Fax : 886-3-5642050

Taipei Branch :

7F, No. 137, Lane 235, Pac Chiao Rd.,
Hsin Tien City, Taipei Hsien, Taiwan, R. O. C.
Tel : 886-2-89191368
Fax : 886-2-89191369