

Features

- **Wide Input Voltage Range from 7.5V to 24V**
- **3A Continuous Output Current**
- **Adjustable Output Voltage from 0.8V to 20V**
- **$V_{REF}=0.8V \pm 1\%$ over all Load & Line Regulation & TC Range**
- **Integrated High/Low Side MOSFET**
- **High Efficiency Performance up to 95% scale**
- **Low Shutdown Current <1mA scale**
- **Built-in Internal 1.5ms Soft-Start & Soft-Stop Functions**
- **Fixed 600kHz Switching Frequency with Maximum 90% Duty**
- **Force PWM Mode Operation**
- **Built-in Current Mode Control for Fast Response & MLCC supports with Internal**
- **Stable with Low ESR Capacitors**
- **Power-On-Reset Detection on VCC & VIN**
- **Over-Temperature Protection**
- **Over Voltage Protection**
- **Current-Limit Protection with Frequency Foldback**
- **Enable/Shutdown Function**
- **Current-Mode Operation with Internal Compensation**
- **Small TDFN3x3-10 packages**
- **Lead Free and Green Devices Available (RoHS compliant)**

General Description

APW8835 is a 3A synchronous buck converter with integrated power MOSFETs. The APW8835 design with a current-mode control scheme, can convert wide input voltage of 7.5V to 24V to the output voltage adjustable from 0.8V to 20V to provide excellent output voltage regulation.

The APW8835 is equipped with force PWM mode operation.

The APW8835 is also equipped with Power-on-reset, soft start and whole protections (under-voltage, over-voltage, over-temperature and current-limit) into a single package. This device, available TDFN3x3-10 provides a very compact system solution external components and PCB area.

Simplified Application Circuit

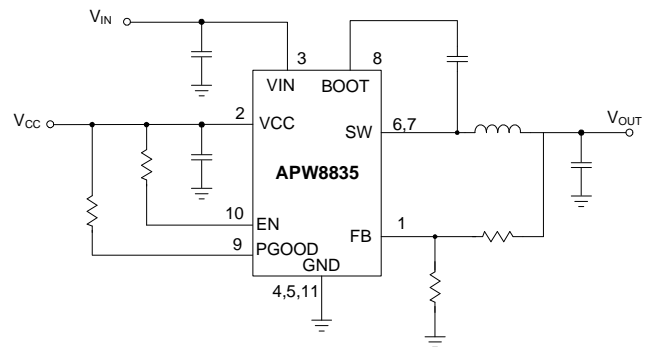

Applications

- **LCD Minitor/TV**
- **Set-Top Box**
- **DSL, Switch HUB**
- **Notebook Computer**

ANPEC reserves the right to make changes to improve reliability or manufacturability without notice, and advise customers to obtain the latest version of relevant information to verify before placing orders.

Ordering and Marking Information

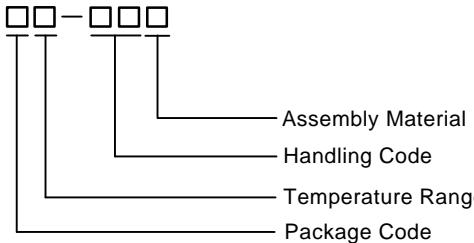
<p>APW8835 — </p>  <p>Assembly Material Handling Code Temperature Range Package Code</p>	<p>Package Code QB : TDFN3x3-10 Operating Junction Temperature I : -40 to 85°C Handling Code TR : Tape & Reel Assembly Material G : Halogen and Lead Free Device</p>
<p>APW8835 QB: APW 8835 XXXXX</p>	<p>X- Date Code</p>

Note: ANPEC lead-free products contain molding compounds/die attach materials and 100% matte tin plate termination finish; which are fully compliant with RoHS. ANPEC lead-free products meet or exceed the lead-free requirements of IPC/JEDEC J-STD-020D for MSL classification at lead-free peak reflow temperature. ANPEC defines “Green” to mean lead-free (RoHS compliant) and halogen free (Br or Cl does not exceed 900ppm by weight in homogeneous material and total of Br and Cl does not exceed 1500ppm by weight).

Pin Configuration

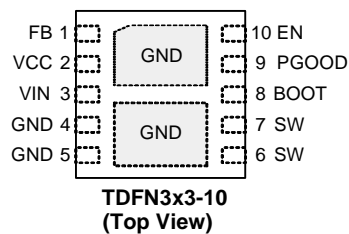

Absolute Maximum Ratings (Note 1)

Symbol	Parameter	Rating	Unit
V_{IN}	VIN Supply Voltage (VIN to GND)	-0.3 ~ 30	V
V_{CC}	VCC Supply Voltage (VCC to GND)	-0.3~6.5	V
V_{SW}	SW to GND Voltage	> 20ns	-1 ~ $V_{IN}+0.3$
		< 20ns	-3 ~ $V_{IN}+3$
	EN, FB, PGOOD to GND Voltage	-0.3 ~ 6.5	V
V_{BOOT}	BOOT to GND Voltage	$V_{SW}-0.3 \sim V_{SW}+6$	V
P_D	Power Dissipation	Internally Limited	W
T_J	Junction Temperature	150	°C
T_{STG}	Storage Temperature	-65 ~ 150	°C
T_{SDR}	Maximum Lead Soldering Temperature(10 Seconds)	260	°C

Note1: Stresses beyond those listed under "absolute maximum ratings" may cause permanent damage to the device. These are stress ratings only and functional operation of the device at these or any other conditions beyond those indicated under "recommended operating conditions" is not implied. Exposure to absolute maximum rating conditions for extended periods may affect device reliability.

Thermal Characteristics

Symbol	Parameter	Typical Value	Unit
θ_{JA}	Junction-to-Ambient Resistance in free air ^(Note 2)	55	°C/W

Note 2: θ_{JA} is measured with the component mounted on a high effective thermal conductivity test board in free air.

Recommended Operating Conditions (Note 3)

Symbol	Parameter	Range	Unit
V_{IN}	VIN Supply Voltage	7.5 ~ 24	V
V_{CC}	VCC Supply Voltage	3 ~ 5.5	V
V_{OUT}	Converter Output Voltage	0.8 ~ 20	V
I_{OUT}	Converter Output Current	0 ~ 3	A
V_{IH_EN}	EN High-Level Input Voltage	1.6~5	V
V_{IL_EN}	EN Low-Level Input Voltage	0~0.4	V
T_A	Ambient Temperature	-40 ~ 85	°C
T_J	Junction Temperature	-40 ~ 125	°C

Note 3: Refer to the application circuit.

Electrical Characteristics

Unless otherwise specified, these specifications apply over $V_{IN}=12V$, $V_{CC}=5V$, $V_{EN}=5V$. Typical values are at $T_A=25^\circ C$.

Symbol	Parameter	Test Conditions	APW8835			Unit
			Min	Typ	Max	
SUPPLY CURRENT						
I_{VCC}	VCC Supply Current	$V_{FB}=0.8V$	-	1.1	-	mA
I_{VCC_SD}	VCC Shutdown Supply Current	$V_{EN}=0V$	-	-	1	μA
POWER-ON-RESET (POR)						
	VIN POR Voltage Threshold	V_{IN} Rising	6.4	6.9	7.4	V
	VIN POR Voltage Hysteresis	V_{IN} Falling	-	0.6	-	V
	VCC POR Voltage Threshold	V_{CC} Rising	2.65	2.8	2.95	V
	VCC POR Voltage Hysteresis	V_{CC} Falling	-	0.3	-	V
REFERENCE VOLTAGE						
V_{REF}	Reference Voltage		-	0.8	-	V
	Output Voltage Accuracy	$I_{OUT}=10mA\sim 3A$, $V_{CC}=3\sim 5V$, $T_A=25^\circ C$	-1.5	-	+1.5	%
OSCILLATOR AND DUTY CYCLE						
F_{OSC}	Oscillator Frequency		-	600	-	kHz
	Maximum Converter's Duty		-	90	-	%
	Minimum on Time		-	100	-	ns
POWER MOSFET						
	High Side MOSFET Resistance	$I_{OUT}=3A$	-	70	105	mΩ
	Low Side MOSFET Resistance	$I_{OUT}=3A$	-	70	105	mΩ
	High Side MOSFET Leakage Current	$V_{EN}=0V$, $V_{SW}=0V$, $V_{IN}=24V$	-	-	10	μA
	Low Side MOSFET Leakage Current	$V_{EN}=0V$, $V_{SW}=24V$, $V_{IN}=24V$	-	-	10	μA

Electrical Characteristics

Unless otherwise specified, these specifications apply over $V_{IN}=12V$, $V_{CC}=5V$, $V_{EN}=5V$. Typical values are at $T_A=25^{\circ}C$.

Symbol	Parameter	Test Conditions	APW8835			Unit
			Min	Typ	Max	
BOOTSTRAP POWER						
	Bootstrap Switch Drop Voltage	$I_F = 10mA$	-		0.2	V
	BOOT Leakage Current	$V_{EN}=0V$, $V_{CC}=5V$, $V_{IN}=V_{SW}=19V$, $V_{BOOT}=24V$	-	-	10	μA
CURRENT-MODE PWM CONVERTER						
gm	Error Amplifier Transconductance			800		$\mu A/V$
	Error Amplifier DC Gain		-	80	-	dB
T_D	Dead Time			20		ns
PROTECTIONS						
	High Side MOSFET current-limit		-	5.3	-	A
	Low Side Switch Current-Limit		-	1	-	A
T_{OTP}	Over-temperature Trip Point		-	150	-	$^{\circ}C$
	Over-temperature Hysteresis		-	20	-	$^{\circ}C$
	Over- Voltage Protection		130	135	140	$\%V_{REF}$
	Under- Voltage Protection		45	50	55	$\%V_{REF}$
SOFT-START, ENABLE AND INPUT CURRENTS						
T_{SS}	Soft-Start Time		0.8	1.5	2	ms
	Enable High Level Voltage	V_{EN} rising	1.6	-	-	V
	Enable Low Level Voltage	V_{EN} falling	-	-	0.4	V
POWER GOOD						
	PGOOD in from lower (PGOOD goes high)	V_{OUT} rising	87	90	93	$\%V_{OUT}$
	PGOOD low hysteresis	V_{OUT} falling	-	5	-	$\%V_{OUT}$
	PGOOD in from higher (PGOOD goes high)	V_{OUT} falling	122	125	128	$\%V_{OUT}$
	PGOOD high hysteresis	V_{OUT} rising	-	5	-	$\%V_{OUT}$
	PGOOD Pull Low Resistance		-	100	-	Ω

Pin Description

PIN		FUNCTION
NO.	NAME	
1	FB	Output Feedback Input. The APW8835 senses the feedback voltage via FB and regulates the voltage at 0.8V. Connecting FB with a resistor-divider from the converter's output sets the output voltage.
2	VCC	Signal Input. The VCC supplies the control circuitry, gate driver. Connect a ceramic bypass capacitor from VCC to GND.
3	VIN	Power Input. The VIN supplies the step-down converter switches. Connect a ceramic bypass capacitor from VIN to GND.
4	GND	Ground. Power and signal ground.
5	GND	
6	SW	Power Switching Output. The SW is the junction of the high-side and low-side power MOSFET to supply power to the output LC filter.
7	SW	
8	BOOT	High-side Gate driver supply Voltage input. The BOOT supplies the voltage to drive the high-side N-channel MOSFET.
9	PGOOD	Power Good Output. This pin is an open-drain logic output that is pulled to the ground when the V_{FB} voltage is out of window. This pin needs a resistor to pull high when PGOOD signal is used.
10	EN	Enable pin of the PWM converter. When the EN is above high logic level, the device is in operation mode. When the EN is below low logic level, the device is in shutdown mode. This pin can not be left open.
11	-	GND and Exposed pad. Connect the exposed pad to the system ground plane with large copper area for dissipating heat into the ambient air.

Block Diagram

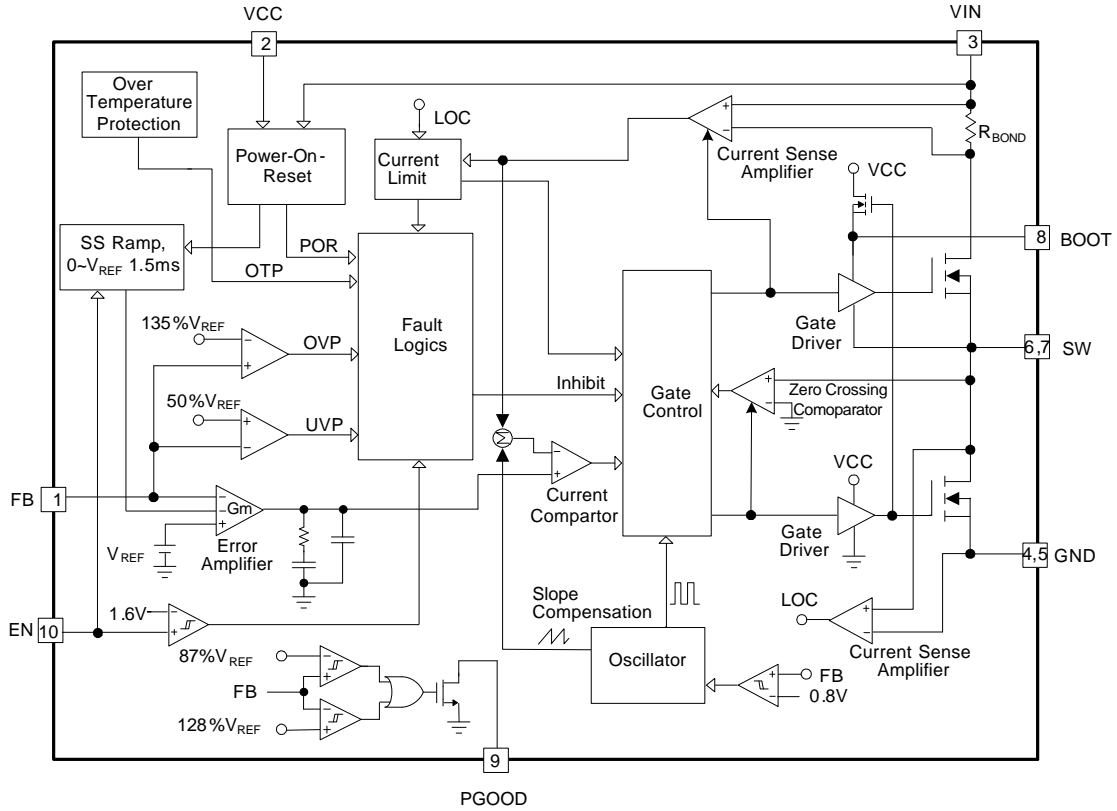

Typical Application Circuit

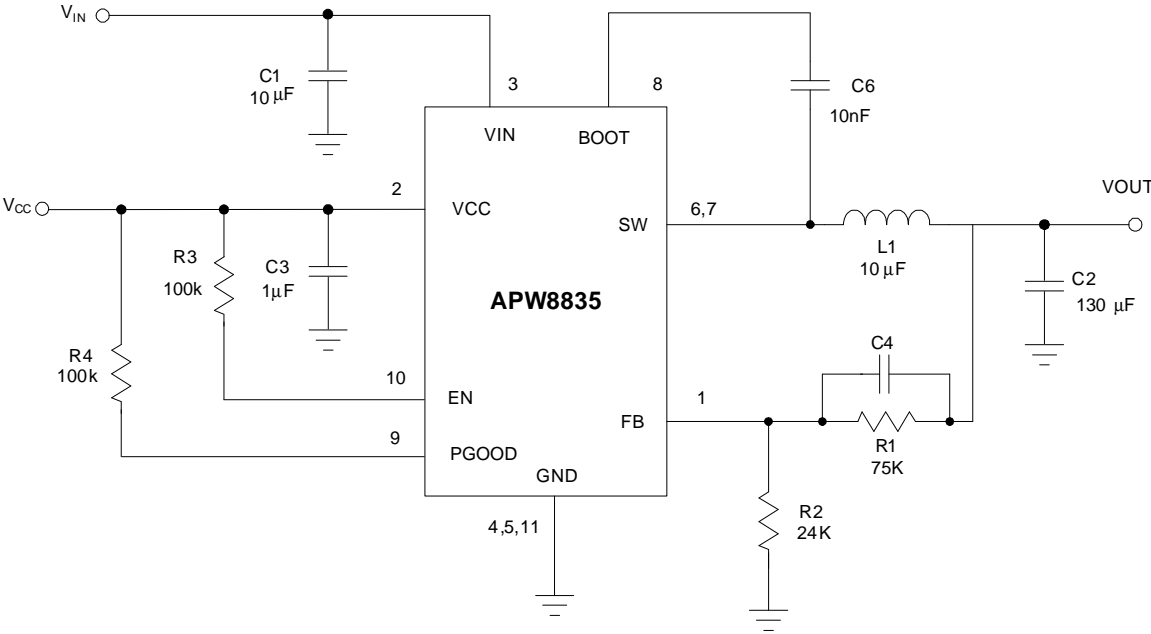

Function Description

Main Control Loop

The APW8835 is a constant frequency current mode switching regulator. During normal operation, the internal N-channel power MOSFET is turned on each cycle when the oscillator sets an internal RS latch and would be turned off when an internal current comparator (ICMP) resets the latch. The peak inductor current at which ICMP resets the RS latch is controlled by the voltage on the COMP pin, which is the output of the error amplifier (EAMP). An external resistive divider connected between VOUT and ground allows the EAMP to receive an output feedback voltage VFB at FB pin. When the load current increases, it causes a slight decrease in VFB relative to the 0.8V reference, which in turn causes the COMP voltage to increase until the average inductor current matches the new load current.

VIN and VCC Power-On-Reset (POR)

The APW8835 keeps monitoring the voltage on VIN and VCC pin to prevent wrong logic operations which may occur when VIN or VCC voltage is not high enough for the internal control circuitry to operate.

After the VIN, VCC and EN voltages exceed their respective voltage thresholds, the IC starts a start-up process and then ramps up the output voltage to the setting of output voltage.

Soft-Start

The APW8835 provides the soft-start function to limit the inrush current. The soft-start time is fixed in 1.5ms.

Over-Temperature Protection (OTP)

The over-temperature circuit limits the junction temperature of the APW8835. When the junction temperature exceeds $T_j = +150^{\circ}\text{C}$, a thermal sensor turns off the N-channel power MOSFET, allowing the device to cool down. The thermal sensor allows the converter to start a start-up process and regulate the output voltage again after the junction temperature cools by 20°C . The OTP designed with a 20°C hysteresis lowers the average T_j during continuous thermal overload conditions, increasing life time of the APW8835.

Enable/Shutdown

Driving EN to ground places the APW8835 in shutdown. When in shutdown, the internal N-Channel power MOSFET turns off, all internal circuitry shuts down and the quiescent supply current reduces to $0.3\mu\text{A}$. Connect a RC network from EN to GND to set a turn-on delay that can be used to sequence the output voltages of multiple devices.

Current-Limit Protection

The APW8835 monitors the output current, flowing through the N-Channel power MOSFET, and limits the current peak at current-limit level to prevent loads and the IC from damages during overload, short-circuit and over-voltage conditions.

Foldback Frequency

The foldback frequency is controlled by the FB voltage. When the FB pin voltage is under 80% of reference (V_{REF}), the frequency of the oscillator will be reduced to 110kHz. This lower frequency allows the inductor current to safely discharge, thereby preventing current runaway. The oscillator's frequency will switch to its designed rate when the feedback voltage on FB rises above the rising frequency foldback threshold (85% of V_{REF} , typical) again.

Bootstrap Capacitor

The APW8835 is an N-channel MOSFET step down converter. The MOSFET requires a gate voltage that is higher than input voltage, thus a boost capacitor should be connected between LX and BS pins to drive the gate of the N-channel MOSFET. Typical bootstrap capacitor value is 10nF.

Function Description (Cont.)

Output Under-Voltage Protection (UVP)

In the operational process, if a short-circuit occurs, the output voltage will drop quickly. Before the current-limit circuit responds, the output voltage will fall out of the required regulation range. The under-voltage continually monitors the FB voltage after soft-start is completed. If a load step is strong enough to pull the output voltage lower than the under-voltage threshold, the IC shuts down converter's output.

The under-voltage threshold is 50% of the nominal output voltage. The under-voltage comparator has a built-in 3ms noise filter to prevent the chips from wrong UVP shutdown being caused by noise. The APW8835 will be latched after under-voltage protection.

Over-Voltage Protection (OVP)

The over-voltage function monitors the output voltage by FB pin. When the FB voltage increases over 135% of the reference voltage due to the high-side MOSFET failure or for other reasons, the over-voltage protection comparator will force the low-side MOSFET gate driver high. This action actively pulls down the output voltage and eventually attempts to blow the internal bonding wires. The APW8835 will be latched after over-voltage protection.

Power OK Indicator

PGOOD is actively held low in shutdown and soft-start status. In the soft-start process, the PGOOD is an open-drain. When the soft-start is finished, the PGOOD is released. In normal operation, the PGOOD window is from 90% to 125% of the converter reference voltage. When the output voltage has to stay within this window, PGOOD signal will become high after 0.5ms internal delay. When the output voltage outruns 87% or 128% of the target voltage, PGOOD signal will be pulled low immediately. In order to prevent false PGOOD drop, capacitors need to parallel at the output to confine the voltage deviation with severe load step transient.

Package Information

TDFN3x3-10

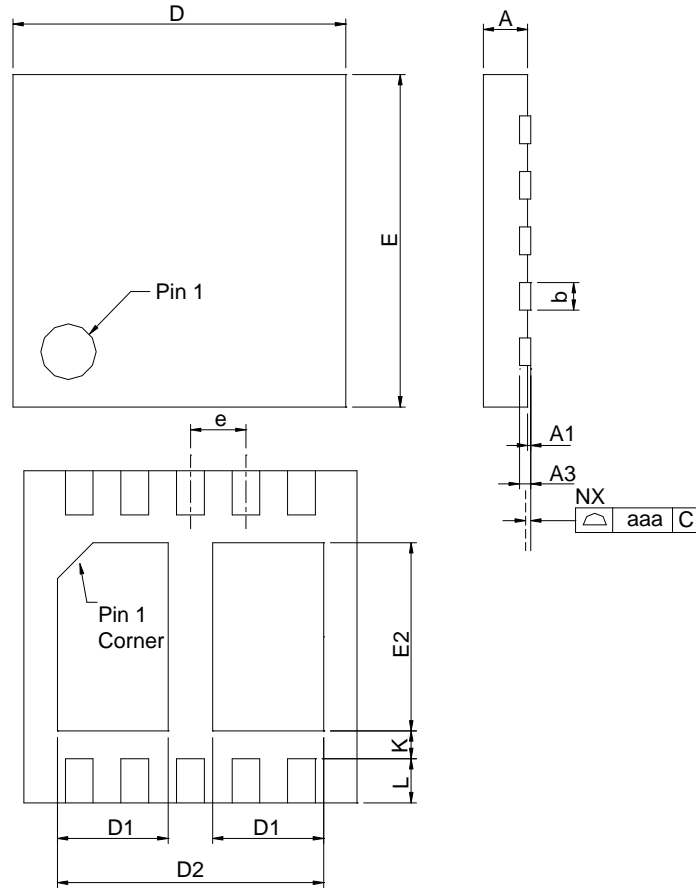

TDFN3x3-10C				
DIMENSIONS	MILLIMETERS		INCHES	
	MIN.	MAX.	MIN.	MAX.
A	0.70	0.80	0.028	0.031
A1	0.00	0.05	0.000	0.002
A3	0.11 REF		0.004 REF	
b	0.18	0.30	0.007	0.012
D	2.90	3.10	0.114	0.122
D1	0.92	1.13	0.036	0.044
D2	2.20	2.40	0.087	0.094
E	2.90	3.10	0.114	0.122
E2	1.40	1.60	0.055	0.063
e	0.50 BSC		0.020 BSC	
L	0.30	0.50	0.012	0.020
K	0.20		0.008	
aaa	0.08		0.003	

Note : 1. Followed from JEDEC MO-229 VEED-5.

Carrier Tape & Reel Dimensions

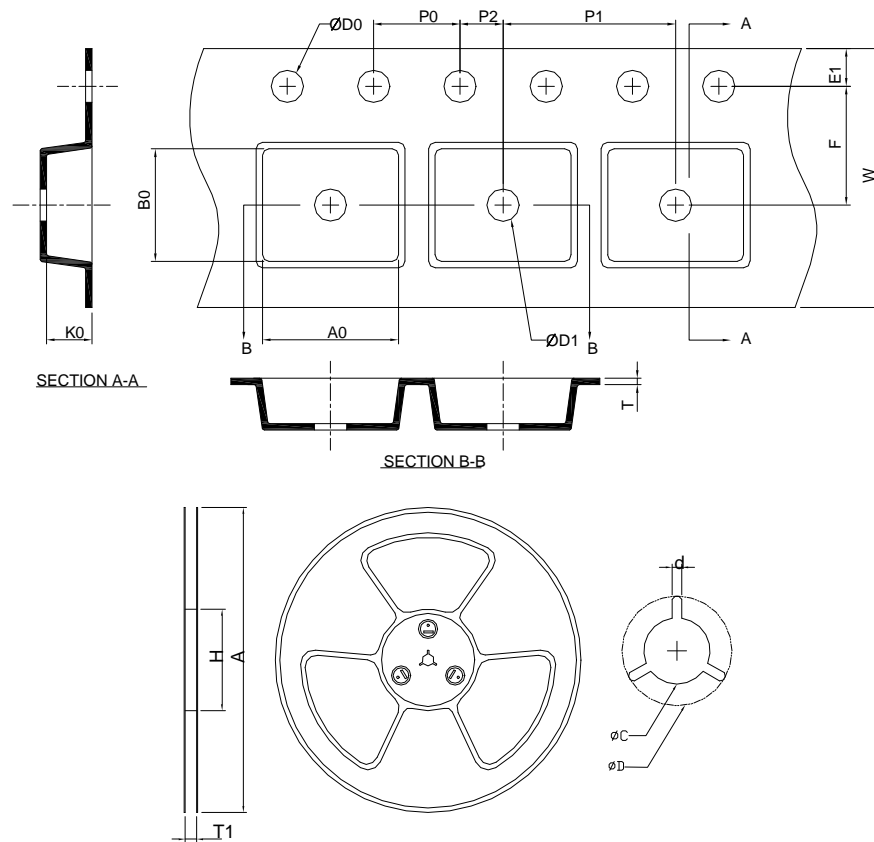

Application	A	H	T1	C	d	D	W	E1	F
TDFN3x3-10	330.0 ±0.00	50 MIN.	12.4+2.00 -0.00	13.0+0.50 -0.20	1.5 MIN.	20.2 MIN.	12.0 ±0.30	1.75 ±0.10	5.5 ±0.05
	P0	P1	P2	D0	D1	T	A0	B0	K0
	4.0 ±0.10	8.0 ±0.10	2.0 ±0.05	1.5+0.10 -0.00	1.5 MIN.	0.6+0.00 -0.40	3.30 ±0.20	3.30 ±0.20	1.30 ±0.20

(mm)

Devices Per Unit

Package Type	Unit	Quantity
TDFN3x3-10	Tape & Reel	3000

Taping Direction Information

TDFN3x3-10

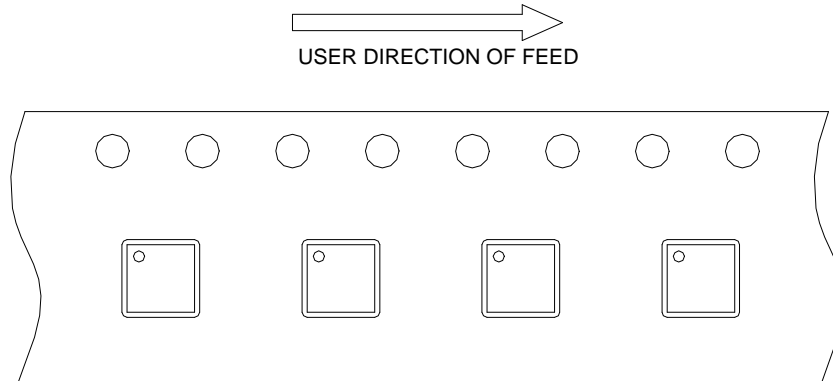

Classification Profile

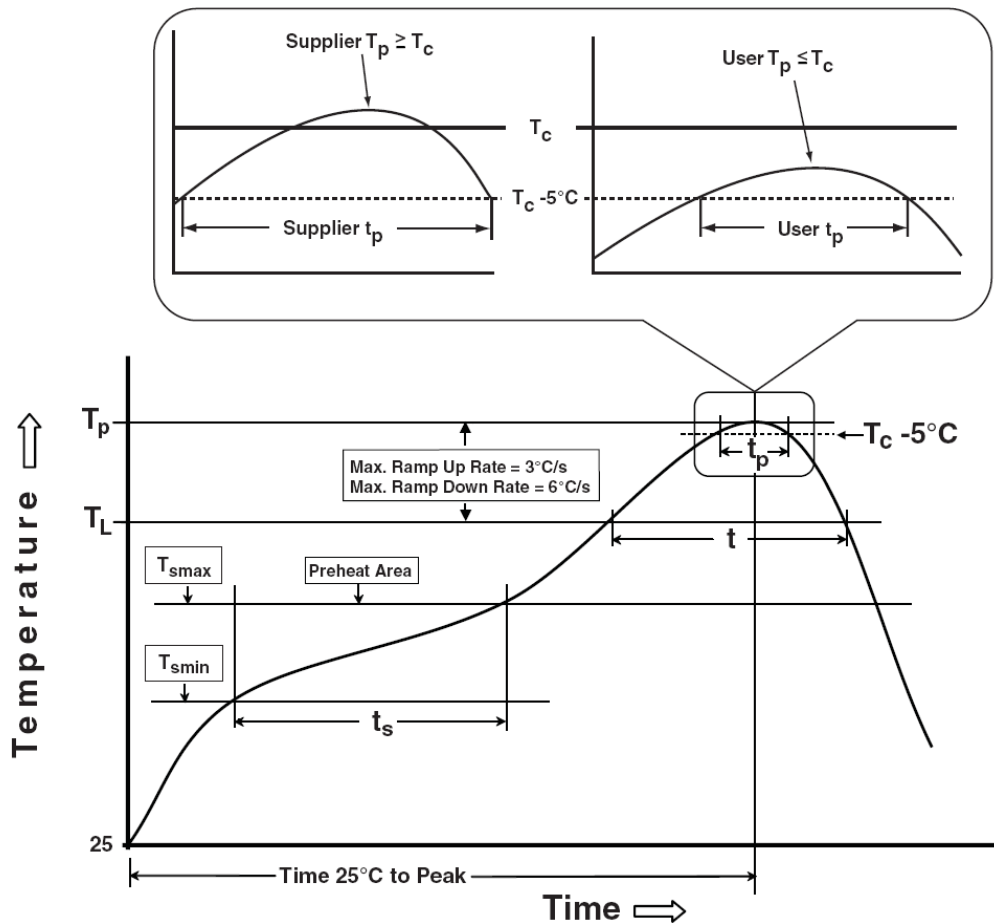

Classification Reflow Profiles

Profile Feature	Sn-Pb Eutectic Assembly	Pb-Free Assembly
Preheat & Soak		
Temperature min (T_{smin})	100 °C	150 °C
Temperature max (T_{smax})	150 °C	200 °C
Time (T_{smin} to T_{smax}) (t_s)	60-120 seconds	60-120 seconds
Average ramp-up rate (T_{smax} to T_p)	3 °C/second max.	3 °C/second max.
Liquidous temperature (T_L)	183 °C	217 °C
Time at liquidous (t_L)	60-150 seconds	60-150 seconds
Peak package body Temperature (T_p)*	See Classification Temp in table 1	See Classification Temp in table 2
Time (t_p)** within 5°C of the specified classification temperature (T_c)	20** seconds	30** seconds
Average ramp-down rate (T_p to T_{smax})	6 °C/second max.	6 °C/second max.
Time 25°C to peak temperature	6 minutes max.	8 minutes max.
* Tolerance for peak profile Temperature (T_p) is defined as a supplier minimum and a user maximum.		
** Tolerance for time at peak profile temperature (t_p) is defined as a supplier minimum and a user maximum.		

Table 1. SnPb Eutectic Process – Classification Temperatures (T_c)

Package Thickness	Volume mm ³ <350	Volume mm ³ ≥350
<2.5 mm	235 °C	220 °C
≥2.5 mm	220 °C	220 °C

Table 2. Pb-free Process – Classification Temperatures (T_c)

Package Thickness	Volume mm ³ <350	Volume mm ³ 350-2000	Volume mm ³ >2000
<1.6 mm	260 °C	260 °C	260 °C
1.6 mm – 2.5 mm	260 °C	250 °C	245 °C
≥2.5 mm	250 °C	245 °C	245 °C

Reliability Test Program

Test item	Method	Description
SOLDERABILITY	JESD-22, B102	5 Sec, 245°C
HOLT	JESD-22, A108	1000 Hrs, Bias @ $T_j=125^\circ\text{C}$
PCT	JESD-22, A102	168 Hrs, 100%RH, 2atm, 121°C
TCT	JESD-22, A104	500 Cycles, -65°C~150°C
HBM	MIL-STD-883-3015.7	VHBM 2KV
MM	JESD-22, A115	VMM 200V
Latch-Up	JESD 78	10ms, 1 _{tr} 100mA

Customer Service

Anpec Electronics Corp.

Head Office :

No.6, Dusing 1st Road, SBIP,
Hsin-Chu, Taiwan, R.O.C.
Tel : 886-3-5642000
Fax : 886-3-5642050

Taipei Branch :

2F, No. 11, Lane 218, Sec 2 Jhongsing Rd.,
Sindian City, Taipei County 23146, Taiwan
Tel : 886-2-2910-3838
Fax : 886-2-2917-3838